

## CD80AF3 and CD80AF4 INDUSTRIAL CONTROL DAMPER GALVANIZED STEEL

### STANDARD CONSTRUCTION

#### FRAME

CD80AF3 – 8" x 2" x 12 gage (203 x 51 x 2.8) steel channel.  
CD80AF4 – 8" x 2" x 10 gage (203 x 51 x 3.5) steel channel.

#### BLADE

CD80AF3 – 5<sup>3</sup>/<sub>4</sub>" to 7<sup>3</sup>/<sub>4</sub>" (146 to 197) wide, double skin airfoil type of 16 gage (1.6) steel for blade lengths to 48" (1219) and 14 gage (2) steel for 48" to 60" (1219 to 1524) blade lengths.  
CD80AF4 – 5<sup>3</sup>/<sub>4</sub>" to 7<sup>3</sup>/<sub>4</sub>" (146 to 197) wide, double skin airfoil type of 12 gage (2.8) steel for blade lengths to 48" (1219) and 10 gage (3.5) steel for 48" to 60" (1219 to 1524) blade lengths.

#### LINKAGE

Side linkage out of airstream. 3/16" x 3/4" (4.8 x 19) plated steel tie bars. 3/8" (9.5) diameter stainless steel pivot pins with lock type retainers. 10 gage (3.5) galvanized steel clevis arms.

#### AXLES

CD80AF3 – 3/4" (19) diameter plated steel.  
CD80AF4 – 3/4" (19) diameter plated steel for blade lengths up to 48" (1219). 1" (25.4) diameter plated steel for 48" to 60" (1219 to 1524) blade lengths.

#### BEARINGS

Stainless steel sleeve bolted to frame.

#### OPERATING LEVER

Hand Quadrant (HQ) for manual operation or Crank Lever (CL) for motor operation.

#### FINISH

Mill.

#### MAXIMUM TEMPERATURE

250°F (121°C) is standard. Damper can be supplied for temperatures between 250°F (121°C) and 400°F (204°C) by increasing clearance between blade ends and frame. Advise Ruskin of maximum operating temperature.

#### MINIMUM SIZE

Single blade, parallel action – 6"w x 6"h (152 x 152).  
Two blade, parallel or opposed action – 6"w x 12"h (152 x 305).

#### MAXIMUM SIZE

60"w x 96"h (1524 x 2438). Consult Ruskin for larger sizes.

### VARIATIONS

Additional variations to those listed in table are available. Consult Ruskin for pricing.

- Higher temperature construction
- Other materials/heavier construction
- Special finishes.

Dimensions in parenthesis ( ) indicate millimeters

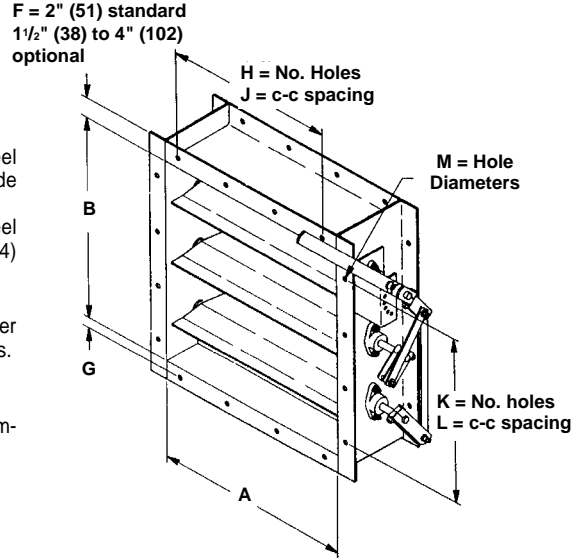

ILLUSTRATED WITH OPTIONAL BOLT HOLES IN FLANGES

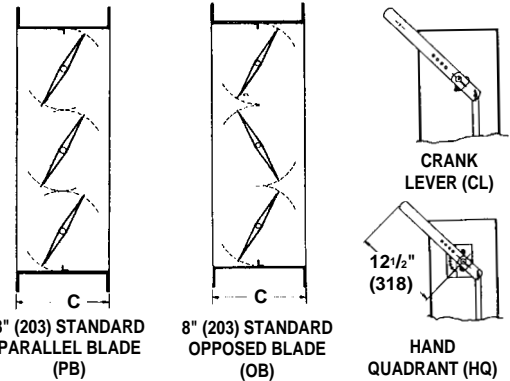

FRAME	BLADES	AXLES	BEARINGS	LINKAGE	SEALS (OPT)	ACCESSORIES
12 GA (2.8) GALVANIZED STEEL	16 GA (1.6) to 48" (1219) 14 GA (2) to 60" (1524) GALV	3/4" (19) DIA. PLATED STEEL	SS SLEEVE IN CAST HSG BOLTED TO FRAME	SIDE LINKAGE (CONCEALED)	BLADE SEALS EPDM 250°F (121°C) MAX	HAND QUADRANT (HQ)
10 GA (3.5) GALVANIZED STEEL	12 GA (2.8) to 48" (1219) 10 GA (3.5) to 60" (1524) GALV	3/4" (19) DIA. PLATED STEEL TO 48", 1" (25.4) DIA PLTD STL OVER 48" (1219) to 60" (1524)	BRGS BOLTED TO FRAME W/INTEGRAL SHAFT SEALS (OPT)		BLADE SEALS SILICONE 400°F (200°C) MAX	CRANK LEVER (CL)
12 GA (2.8) 304SS	16 GA (1.6) 304SS to 48" (1219) 14 GA (2) 304SS to 60" (1524)	1" (25.4) DIA PLTD STL (OPT)	OUTBOARD BRGS W/SHAFT SEALS (OPT)		SS JAMB SEALS	BOLT HOLES ONE FLANGE (OPT)
10 GA (3.5) 304SS	12 GA (2.8) 304SS to 48" (1219) 10 GA (3.5) 304SS to 60" (1524)	3/4" (19) DIA. SS (Opt)				BOLT HOLES BOTH FLANGES (OPT)
12 GA (2.8) 316SS	16 GA (1.6) 316SS to 48" (1219) 14 GA (2) 316SS to 60" (1524)	1" (25.4) DIA. SS (Opt)				PNEUMATIC ACTUATOR (OPT)
10 GA (3.5) 316SS	12 GA (2.8) 316SS to 48" (1219) 10 GA (3.5) 316SS to 60" (1524)	1" (25.4) DIA. SS (Opt)				ELECTRIC ACTUATOR (OPT)
						1 1/2" (38) TO 4" (102) FLANGES (OPT)

QTY.	MODEL	BLADE ACTION	DIMENSIONS											COMMENTS	TAG	
			PB	OB	A	B	C	F	G	H	J	K	L			M

PROJECT

REPRESENTATIVE

CONTRACTOR

ARCH./ENGR.

LOCATION:

DATE

# CD80AF3 and CD80AF4 PERFORMANCE DATA

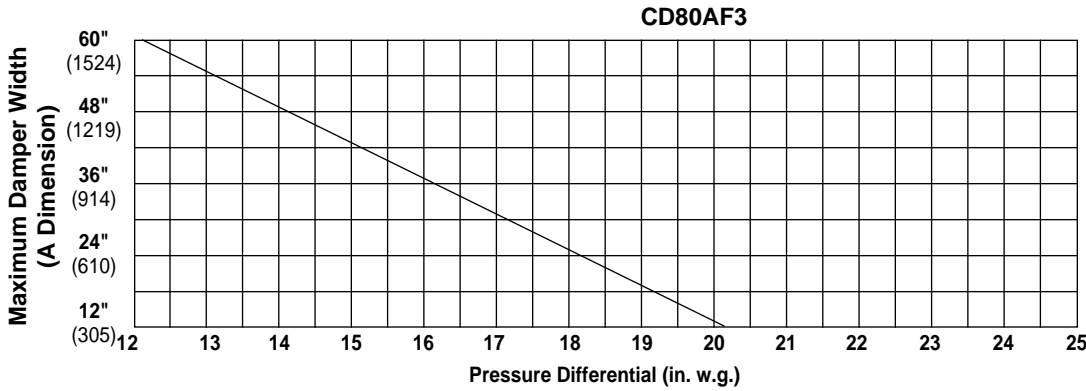

Pressure limitations shown on charts at left allow maximum blade deflection of 1/180 of span on 60" damper widths. Deflections in other damper widths, (less than 48" [1219]) at higher pressures shown will result in blade deflection substantially less than 1/180 of span.

The CD80AF3 may be used in systems with total pressure exceeding 13" w.g. by reducing the damper section with as indicated in the chart. A maximum design total pressure of 17" w.g. would require at CD80AF3 damper with maximum section width of 36" (914).

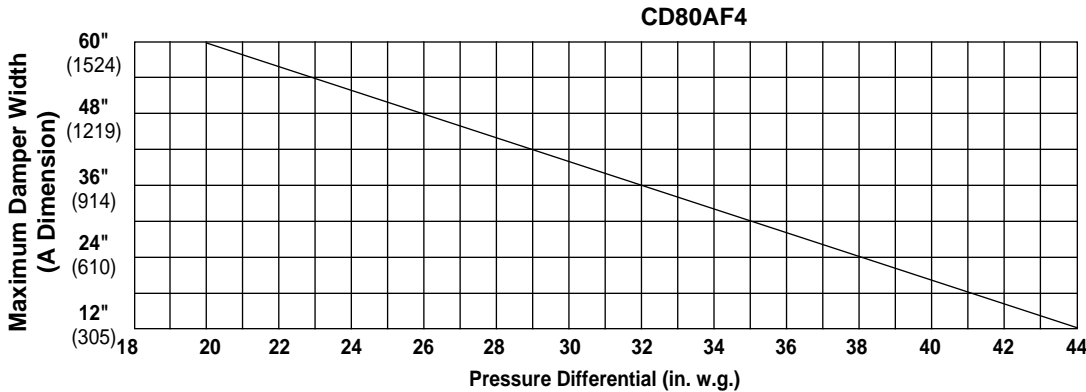

**\*NOTE:** Damper should be specified for fan shut off pressure. Pressure differential is **not** system pressure, but is the maximum pressure the damper will encounter with blades closed.

The CD80AF4 may be used in systems with total pressure exceeding 20" w.g. by reducing the damper section width as indicated in the chart. A maximum design total pressure of 26" w.g., for example, would require a CD80AF4 damper with maximum section width of 48" (1219). The CD80AF dampers may tolerate higher pressure limitations than those shown here. Conservative ratings are presented intentionally in an effort to avoid misapplication. Consult Ruskin on your Ruskin representative when a damper is to be applied in conditions exceeding recommended maximums.

## CD80AF3 SUGGESTED SPECIFICATION

Furnish and install, at locations shown in plans or in accordance with schedules, industrial grade control dampers meeting the following construction standards: Frame shall be minimum 8" deep x 2" flanged 12 gage (203 x 51 x 2.8), galvanized steel channel. Blades shall be double skin airfoil design, maximum 7<sup>3</sup>/<sub>4</sub>" (197) wide and minimum 16 gage (1.6) galvanized steel for blade lengths up to 48" (1219) and 14 gage (2) galvanized steel from 48" (1219) thru 60" (1524). Axles shall be minimum 3/4" (19) diameter plated steel rod. Bearing shall be stainless steel sleeve pressed into cast housing bolted to the damper frame. Oil impregnated bronze or press fit bearings are not acceptable. Linkage shall be located in jamb out of airstream and constructed of minimum 10 gage (3.5) steel double clevis arms with 3/16" x 3/4" (4.8 x 19) plated steel tie bars pivoting on 3/8" (9.5) diameter stainless steel pivot pins

with lock type retainers. Face linkage in airstream is not acceptable. Standard construction shall include (specifier choose) locking hand quadrant for manual operation or crank lever for motor operation. Submittal data must include leakage, pressure drop and maximum pressure data based on AMCA Standard 500 testing. Data shall be for full range of damper sizes. Data from one size sample test is not acceptable. Damper shall be Ruskin model CD80AF3 Control Damper.

### ADD TO SPECIFICATION IF REQUIRED:

Dampers shall be equipped with blade and jamb seals for low leakage application. Blade seals shall be mechanically attached to blade. Adhesive type seals are not acceptable. Jamb seals shall be flexible stainless steel located between blade edge and jamb for maximum sealing compression. Wind stops or sponge seals are not acceptable.

## CD80AF4 SUGGESTED SPECIFICATION

Furnish and install, at locations shown in plans or in accordance with schedules, industrial grade control dampers meeting the following construction standards: Frame shall be minimum 8" deep x 2" flanged 10 gage (203 x 51 x 3.5), galvanized steel channel. Blades shall be double skin airfoil design, maximum 7<sup>3</sup>/<sub>4</sub>" (197) wide and minimum 12 gage (2.8) galvanized steel for blade lengths up to 48" (1219) and 10 gage (3.5) galvanized steel from 48" (1219) thru 60" (1524). Axles shall be minimum 3/4" (19) diameter plated steel rod for blade lengths up to 48" (1219) and 1" (25.4) diameter for 48" (1219) to 60" (1524) blade lengths. Bearing shall be stainless steel sleeve pressed into cast housing bolted to the damper frame. Oil impregnated bronze or press fit bearings are not acceptable. Linkage shall be located in jamb out of airstream and constructed of minimum 10 gage (3.5) steel double clevis arms with 3/16" x 3/4" (4.8 x 19) plated steel tie bars pivoting on 3/8"

(9.5) diameter stainless steel pivot pins with lock type retainers. Face linkage in airstream is not acceptable. Standard construction shall include (specifier choose) locking hand quadrant for manual operation or crank lever for motor operation. Submittal data must include leakage, pressure drop and maximum pressure data based on AMCA Standard 500 testing. Data shall be for full range of damper sizes. Data from one size sample test is not acceptable. Damper shall be Ruskin model CD80AF4 Control Damper.

### ADD TO SPECIFICATION IF REQUIRED:

Dampers shall be equipped with blade and jamb seals for low leakage application. Blade seals shall be mechanically attached to blade. Adhesive type seals are not acceptable. Jamb seals shall be flexible stainless steel located between blade edge and jamb for maximum sealing compression. Wind stops or sponge seals are not acceptable.

# PRESSURE DROP INFORMATION

## AREA FACTOR TABLE

Model	B Dim. Height In Inches (mm)	Dimension A – Width In Inches																		
		6" (152)	9" (229)	12" (305)	15" (381)	18" (457)	21" (533)	24" (610)	27" (686)	30" (762)	33" (838)	36" (914)	39" (991)	42" (1067)	45" (1143)	48" (1219)	51" (1295)	54" (1372)	57" (1448)	60" (1524)
AF3	6" (152)	6.55	4.37	3.28	2.62	2.18	1.87	1.64	1.46	1.31	1.19	1.09	1.01	.94	.87	.82	.77	.73	.69	.66
AF4		6.65	4.43	3.33	2.66	2.22	1.90	1.66	1.48	1.33	1.21	1.11	1.02	.92	.89	.83	.85	.80	.76	.72
AF3	9" (229)	3.89	2.60	1.95	1.56	1.30	1.11	.97	.87	.78	.71	.65	.60	.56	.52	.49	.46	.43	.41	.39
AF4		3.93	2.62	1.96	1.57	1.31	1.12	.98	.87	.79	.71	.65	.60	.56	.52	.49	.48	.46	.43	.41
AF3	12" (305)	2.72	1.81	1.36	1.09	.91	.78	.68	.60	.54	.49	.45	.42	.39	.36	.34	.32	.30	.29	.27
AF4		2.75	1.84	1.38	1.10	.92	.79	.69	.61	.55	.50	.46	.42	.39	.37	.34	.34	.33	.31	.29
AF3	15" (381)	2.03	1.35	1.01	.81	.68	.58	.51	.45	.41	.37	.34	.31	.29	.27	.25	.24	.23	.21	.20
AF4		2.05	1.37	1.02	.82	.68	.59	.51	.46	.41	.37	.34	.32	.29	.27	.26	.25	.24	.23	.21
AF3	18" (457)	1.72	1.14	.86	.69	.57	.49	.43	.38	.34	.31	.29	.26	.25	.23	.21	.20	.19	.18	.17
AF4		1.74	1.16	.87	.69	.58	.50	.43	.39	.35	.32	.29	.27	.25	.23	.22	.22	.20	.19	.18
AF3	24" (610)	1.25	.84	.63	.50	.42	.36	.31	.28	.25	.23	.21	.19	.18	.17	.16	.15	.14	.13	.13
AF4		1.27	.85	.63	.51	.42	.36	.32	.28	.25	.23	.21	.20	.18	.17	.16	.16	.15	.14	.13
AF3	30" (762)	.95	.64	.48	.38	.32	.27	.24	.21	.19	.17	.16	.15	.14	.13	.12	.11	.11	.10	.10
AF4		.96	.64	.48	.39	.32	.28	.24	.21	.19	.18	.16	.15	.14	.13	.12	.12	.11	.11	.10
AF3	36" (914)	.79	.53	.40	.32	.26	.23	.20	.18	.16	.14	.13	.12	.11	.11	.10	.09	.09	.08	.08
AF4		.80	.53	.40	.32	.27	.23	.20	.18	.16	.15	.13	.12	.11	.11	.10	.10	.09	.09	.08
AF3	42" (1067)	.68	.45	.34	.27	.23	.19	.17	.15	.14	.12	.11	.10	.10	.09	.08	.08	.08	.07	.07
AF4		.68	.46	.34	.27	.23	.20	.17	.15	.14	.12	.11	.10	.10	.09	.09	.08	.08	.08	.07
AF3	48" (1219)	.59	.39	.30	.24	.20	.17	.15	.13	.12	.11	.10	.09	.08	.08	.07	.07	.07	.06	.06
AF4		.60	.40	.30	.24	.20	.17	.15	.13	.12	.11	.10	.09	.09	.08	.07	.07	.07	.07	.06
AF3	54" (1372)	.52	.35	.26	.21	.17	.15	.13	.12	.10	.10	.09	.08	.07	.07	.07	.06	.06	.06	.05
AF4		.53	.35	.26	.21	.18	.15	.13	.12	.11	.10	.09	.08	.08	.07	.07	.07	.06	.06	.06
AF3	60" (1524)	.46	.31	.23	.19	.15	.13	.12	.10	.09	.08	.08	.07	.07	.06	.06	.05	.05	.05	.05
AF4		.47	.31	.23	.19	.16	.13	.12	.10	.09	.08	.08	.07	.07	.06	.06	.06	.05	.05	.05
AF3	66" (1776)	.42	.28	.21	.17	.14	.12	.11	.09	.08	.08	.07	.06	.06	.06	.05	.05	.05	.04	.04
AF4		.42	.28	.21	.17	.14	.12	.11	.09	.08	.08	.07	.07	.06	.06	.06	.05	.05	.05	.04
AF3	72" (1829)	.39	.26	.19	.16	.13	.11	.10	.09	.08	.07	.06	.06	.06	.05	.05	.05	.04	.04	.04
AF4		.39	.26	.19	.16	.13	.11	.10	.09	.08	.07	.06	.06	.06	.05	.05	.05	.05	.04	.04
AF3	78" (1981)	.36	.24	.18	.14	.12	.10	.09	.08	.07	.06	.06	.05	.05	.05	.04	.04	.04	.04	.04
AF4		.36	.24	.18	.14	.12	.10	.09	.08	.07	.07	.06	.06	.05	.05	.04	.04	.04	.04	.04
AF3	84" (2134)	.33	.22	.17	.13	.11	.09	.08	.07	.07	.06	.06	.05	.05	.04	.04	.04	.04	.04	.03
AF4		.33	.22	.17	.13	.11	.10	.08	.07	.07	.06	.06	.05	.05	.04	.04	.04	.04	.04	.03
AF3	90" (2286)	.31	.21	.16	.12	.10	.09	.08	.07	.06	.06	.05	.05	.04	.04	.04	.04	.03	.03	.03
AF4		.31	.21	.16	.12	.10	.09	.08	.07	.06	.06	.05	.05	.04	.04	.04	.04	.04	.04	.03
AF3	96" (2438)	.29	.19	.14	.11	.10	.08	.07	.06	.06	.05	.05	.04	.04	.04	.04	.03	.03	.03	.03
AF4		.29	.19	.14	.12	.10	.08	.07	.06	.06	.05	.05	.04	.04	.04	.04	.04	.03	.03	.03

## DETERMINING PRESSURE DROP

Use the Area Factor Table and Pressure Drop Chart to determine pressure drop through Ruskin CD80AF3/CD80AF4 control dampers.

- Determine area factor for damper by entering the area factor table with duct width and height.
- Find the conversion velocity (CV) by multiplying the selected size damper's area factor by the flow rate in CFM:  $CV = \text{Area Factor} \times \text{CFM}$ .
- Enter the pressure drop chart at the determined area factor and proceed up to appropriate conversion velocity (CV) line. Then, read across to pressure drop at left side of chart.

**EXAMPLE:** 1. Find the pressure drop across a 18" wide x 18" (457 x 457) high Model CD80AF4 control damper handling 8570 CFM. From the Area Factor Table, area factor is determined to be .58.  
 2. **CFM x AREA FACTOR EQUALS CONVERSION VELOCITY.** Therefore, CV (Conversion Velocity) = 8570 CFM x .58 = 5000. Using the Pressure Drop Chart, pressure drop = .22 inches water gage.

**NOTES:** 1. Ratings are based on AMCA Standard 500 using Test Setup Apparatus Figure 5.3 (damper is installed with duct upstream and downstream).  
 2. Static Pressure and Conversion Velocities are corrected to .075 lb./cu. ft. air density.

## CD80AF PRESSURE DROP CHART

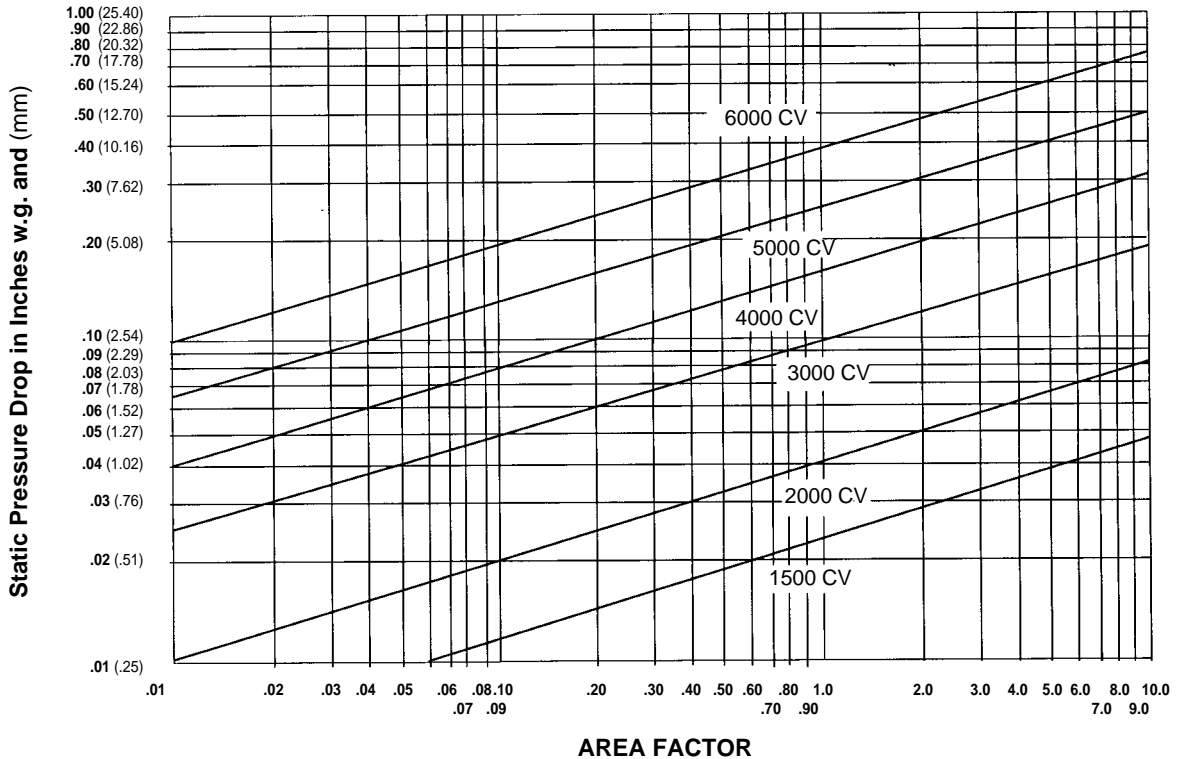

## CD80AF3 and CD80AF4 PERFORMANCE DATA

CD80AF3								
DAMPER WIDTH INCHES (MM)	MAX. SYSTEM PRESSURE	MAX. SYSTEM VELOCITY	Leakage w/o Seals*		Leakage with Seals*		Ultra-Low Leakage**	
			Percent of Max. Flow	CFM/Sq. Ft.	Percent of Max. Flow	CFM/Sq. Ft.	Percent of Max. Flow	CFM/Sq. Ft.
60" (1524)	13.0" w.g.	5000	0.64	32.0	0.08	4.0	0.06	2.9
48" (1219)	15.0" w.g.	5000	0.64	32.0	0.08	4.0	0.06	2.9
36" (914)	17.0" w.g.	5000	0.64	32.0	0.08	4.0	0.06	2.9
24" (610)	19.0" w.g.	6000	0.67	40.0	0.13	8.0	0.10	5.8
12" (305)	21.0" w.g.	6000	1.00	60.0	0.22	13.0	0.16	9.5

CD80AF4								
DAMPER WIDTH INCHES (MM)	MAX. SYSTEM PRESSURE	MAX. SYSTEM VELOCITY	Leakage w/o Seals*		Leakage with Seals*		Ultra-Low Leakage**	
			Percent of Max. Flow	CFM/Sq. Ft.	Percent of Max. Flow	CFM/Sq. Ft.	Percent of Max. Flow	CFM/Sq. Ft.
60" (1524)	20.0" w.g.	5000	0.64	32.0	0.08	4.0	0.06	2.9
48" (1219)	26.0" w.g.	5000	0.64	32.0	0.08	4.0	0.06	2.9
36" (914)	32.0" w.g.	5000	0.64	32.0	0.08	4.0	0.06	2.9
24" (610)	35.0" w.g.	6000	0.67	40.0	0.13	8.0	0.10	5.8
12" (305)	44.0" w.g.	6000	1.00	60.0	0.22	13.0	0.16	9.5

\*Leakage information based on pressure differential of 1" w.g. tested per AMCA Std. 500.

\*\*For details on "Ultra-Low Leakage," contact Ruskin.

### LEAKAGE CORRECTION FACTOR

Static Pressure (in. w.g.)	1	2	3	4	5	6	7	8	9	10	11	12	13	14	15	16	17	18	19	20
Correction Factor	1.0	1.4	1.7	2.0	2.2	.24	2.6	2.8	3.0	3.2	3.3	3.5	3.6	3.7	3.9	4.0	4.1	4.2	4.4	4.5

### DETERMINING LEAKAGE

To determine leakage per square foot at static pressure differentials higher than one inch water gage, multiply leakage at one inch (determined from appropriate table above) by correction factor for higher static pressure (determined from the Leakage Correction Factor Table).

Example: Find leakage per square foot for a 36" wide (914) damper equipped with optional blade and jamb seals at 3" water gage: 4 CFM per sq. foot x 1.7 = 6.8 CFM per sq. foot leakage at 3 inches water gage.

Leakage ratings are based on AMCA Standard 500 using Test Setup Apparatus Figure 5.5. Torque applied holding damper closed at 10 in. lbs. per sq. ft. of damper with minimum of 20 in. lbs.

### INSTALLATION

For proper operation, damper must be installed square and free from racking. Opposed blade dampers must be operated from a power blade on the drive axle.

#### NOTE:

Dampers are designed for operation with blades running horizontally. Dampers to be installed with vertical blades require thrust collars be added at time of damper manufacture and at additional cost. Some standard features are not available with vertical bladed dampers.

# RUSKIN®

3900 Dr. Greaves Rd.  
Kansas City, MO 64030  
(816) 761-7476  
FAX (816) 765-8955  
www.ruskin.com