

## INSTALLATION INSTRUCTIONS

### FSD35GA, FSD36GA, FSD60GA, FSD60-2GA, FSD35SSGA, FSD36SSGA AND FSD37SSGA COMBINATION FIRE AND SMOKE DAMPERS

1 1/2 HOUR UL555 RATED UL555S LEAKAGE RATED CLASS 1, 2 AND 3

#### APPLICATION

The FSDxx/GA series dynamic fire dampers are for use in dynamic (fans on) or static (fans off) systems. Grille access "GA" combination fire smoke dampers are designed to be installed from one side of the wall or partition and permit access to the dampers component through the wall grille. GA combination fire smoke dampers may be used in fire resistance rating applications of less than 3 hours.

#### FSD35GA, FSD36GA MAXIMUM UL CLASSIFIED SIZES

Vertical installation – 36"w x 36"h (914 x 914)

#### FSD35SSGA, FSD36SSGA MAXIMUM UL CLASSIFIED SIZES

Vertical installation – 30"w x 36"h (762 x 914)

#### FSD37SSGA MAXIMUM UL CLASSIFIED SIZES

Vertical installation – 24"w x 32"h (610 x 813)

#### FSD60GA, FSD60-2GA MAXIMUM UL CLASSIFIED SIZES

Vertical installation – 32"w x 36"h (813 x 914)

Dimensions shown in parentheses ( ) indicate millimeters.

#### INSTALLATION SUPPLEMENTS

Refer to the appropriate Ruskin installation instruction supplements for additional information or special requirements:

- Drivemate No. 14880 Breakaway Connection
- Flanged System Breakaway Connections
- Cavity Shaft Wall Metal Stud Framing
- TS150 FireStat for "Reopenable" Combination Fire and Smoke Dampers
- SP100 Switch Package
- EFL Electric Resettable "Fuse" Link
- EFL/SP100 Electric Resettable "Fuse" Link
- PFL Pneumatic Fuse Link
- DSDF Flow Rated Duct Smoke Detector
- DSDN No-Flow Rated Duct Smoke Detector

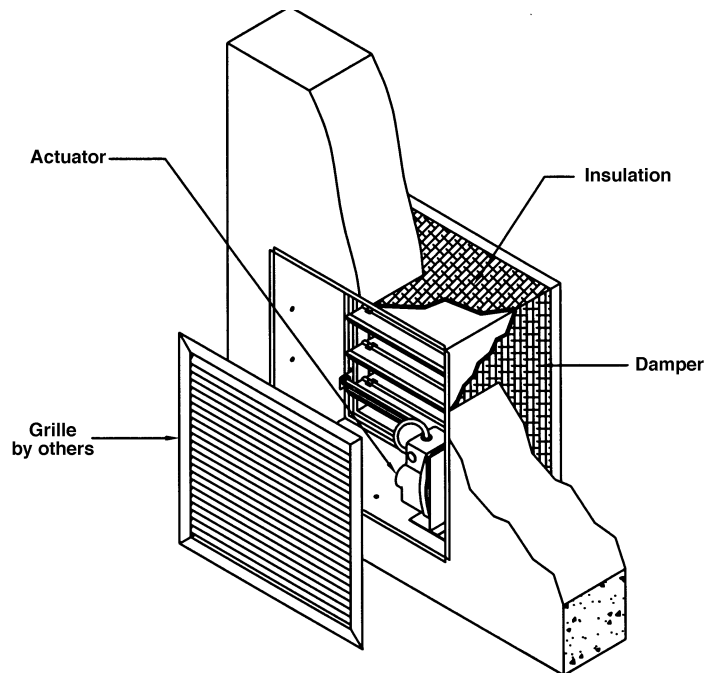

SEE COMPLETE MARKING  
ON PRODUCT

California State Fire Marshal Listing No.

FSD35GA – 3235-0245:0125

FSD36GA – 3235-0245:0124

FSD37GA – 3235-0245:0127

FSD60GA – 3235-0245:0126

NYC Department Of Building MEA 252-05-E

## GENERAL INSTALLATION

### 1. Opening Clearance

Opening clearance for expansion is not required for the Grille Access dampers. However, to accommodate for the sleeve and insulation thickness, the finished opening needs to be 1/2" (13) larger in width and height than the damper nominal size. For example a 24" x 20" (610 x 508) damper the finished opening should be minimum of 24 1/2" x 20 1/2" (622 x 521). The wall-board may be finished to enhance the appearance of the opening.

### 2. Damper Orientation

Dampers are designed to operate with blades running horizontally, only units with "V" can be mounted with vertical blades. Use "Mount With Arrow Up" label as a guide for proper damper orientation. The maximum the leading edge of the damper frame can be installed outside the wall:

- Steel Stud or Masonry Walls: 8" (203)
- Wood Stud Walls: 6" (152)

### 3. Insulation

Insulation shall be 1/4" (6) fiberfrax attached to all four sides of the damper and sleeve assembly (factory installed).

### 4. Damper Sleeve

Sleeve thickness must be equal to or thicker than the duct connected to it. Sleeve gage requirements are listed in the SMACNA Fire, Smoke and Radiation Damper Installation Guide for HVAC Systems and in NFPA90A. If a breakaway style duct/sleeve connection is not used, the Sleeve shall be a minimum of 16 gage (1.6) for dampers up to 36" (914) wide by 24" (610) high and 14 gage (1.9) for dampers exceeding 36" (914) wide by 24" (610) high. Damper sleeve shall not extend more than 6" (152) beyond the fire wall or partition unless damper is equipped with an actuator and/or factory installed access door. Sleeve may extend up to 16" (406) beyond the fire wall or partition on sides equipped with actuator and/or factory installed access door. Sleeve shall terminate at both sides of wall within dimensions shown.

### 5. Fasteners

- Fasteners spacing to attach the damper sleeve to the wall, minimum of 1 fastener per side.  
Steel Stud or Masonry Walls: 12" (305) c-to-c  
Wood Stud Walls: 6" (152) c-to-c
- Fastener to attach mounting angles to the wall  
**In masonry walls** use minimum #10 self-tapping concrete anchors. Screw must engage the wall a minimum of 1 1/2" (38).  
**In metal stud walls** use minimum #10 (M5) screws. Screw must engage the metal stud a minimum of 1/2" (13).  
**In wood stud walls** use minimum #10 (M5) screws. Screw must engage the wood a minimum of 3/4" (19).

### 6. Mounting Angles

Grille mounting flange is integral with the damper sleeve. No other mounting angles are required on front or backside of sleeve.

## 7. Duct/Sleeve Connection

### a. Break-away Duct/Sleeve Connection

Rectangular ducts must use one or more of the connections depicted below:

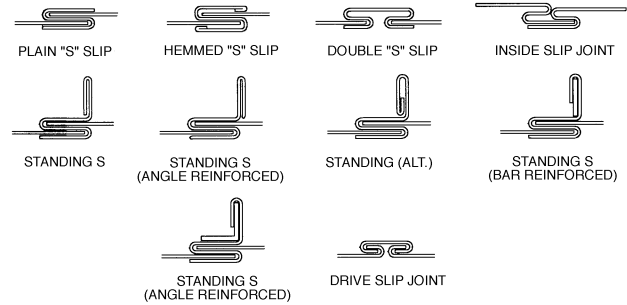

A maximum of two #10 (M5) sheet metal screws on each side and the bottom, located in the center of the slip pocket and penetrating both sides of the slip pocket may be used. Connections using these slip joints on the top and bottom with flat drive slips up to 20" (508) long on the sides may also be used.

### b. Round and Oval Break-away Connections

Round and oval break-away connections must use either a 4" (102) wide drawband or #10 (M5) sheet metal screws spaced equally around the circumference of the duct as follows:

- Duct diameters 22" (559) and smaller – maximum 3 screws.
- Duct diameters over 22" (559) and including 36" (914) – maximum 5 screws.
- Duct diameters over 36" (914) and up to and including 191" (4851) total perimeter – maximum 8 screws.

For flat oval ducts, the diameter is considered the largest (major) dimension of the duct. These connections are depicted in the SMACNA Fire, Smoke, and Radiation Damper Installation Guide.

**Note:** When optional sealing of these joints is desired, the following sealants may be applied in accordance with the sealant manufacturer's instructions:

- Design Polymeric – DP 1010
- Precision – PA2084T
- Hardcast, Inc. – Iron Grip 601
- Eco Duct Seal 44-52

### c. Flanged Break-away Style Duct/Sleeve Connections.

Flanged connection systems manufactured by Ductmate, Nexus or Ward and roll-formed flanged connection by TDF and TDC are approved breakaway connections. Connection between manufactured systems may be used with metal or plastic cleats, Butyl or neoprene gaskets, and/or bolted or non-bolted corners. See Flanged System Breakaway Connections Installation Instruction Supplement for detail.

### d. Non-Break-away Duct/Sleeve Connections

If other duct/sleeve connections are used, the sleeve shall be a minimum of 16 gage (1.6) for dampers up to 36" (914) wide x 24" (610) high and 14 gage (2.0) for dampers larger than 36" (914) wide x 24" (610) high.

## 8. Actuator Connections

Electric and pneumatic actuators are to be connected in accordance with wiring and piping diagrams developed in compliance with applicable codes, ordinances and regulations.

## 9. Installation and Maintenance

Install dampers so they are square and free from racking. Do not compress or stretch damper frames into the duct or opening. Lift or handle dampers using the sleeve or frame. Do not lift dampers using the blades or actuators. Dampers and their actuator(s) must be maintained, cycled, and tested in accordance with local codes, actuator manufacturer recommendations, and recognized standards or publications like: NFPA 80, 90A, 92A, 92B, 101, 105 and UL864.

---

## VERTICAL INSTALLATION

ITEM	DESCRIPTION
1.	Actuator (location may vary)
2.	Auxiliary operating jackshaft
3.	Damper
4.	Over-Center Link
5.	Sleeve
6.	1/4" (6) thick Insulation (factory installed)
7.	Fasteners – See Note #5
8.	Duct/Sleeve connection
9.	Duct
10.	Wall: steel or wood stud or masonry
11.	Grille "By Others"

**Important Note:** For dampers larger than 36"w x 36"h (914 x 914) through 48"w x 48"h (1219 x 1219) see FSD60AF model.

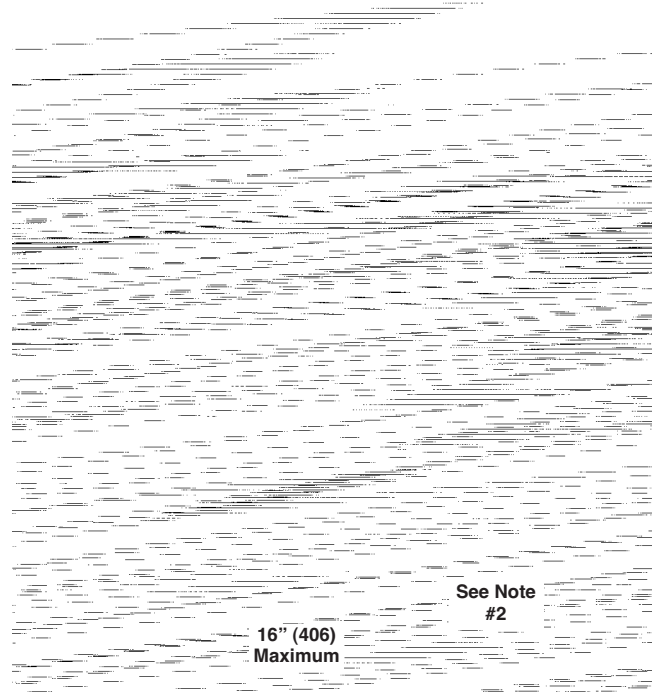

## RECOMMENDED FRAMING FOR OPENINGS IN WOOD AND METAL STUD WALLS

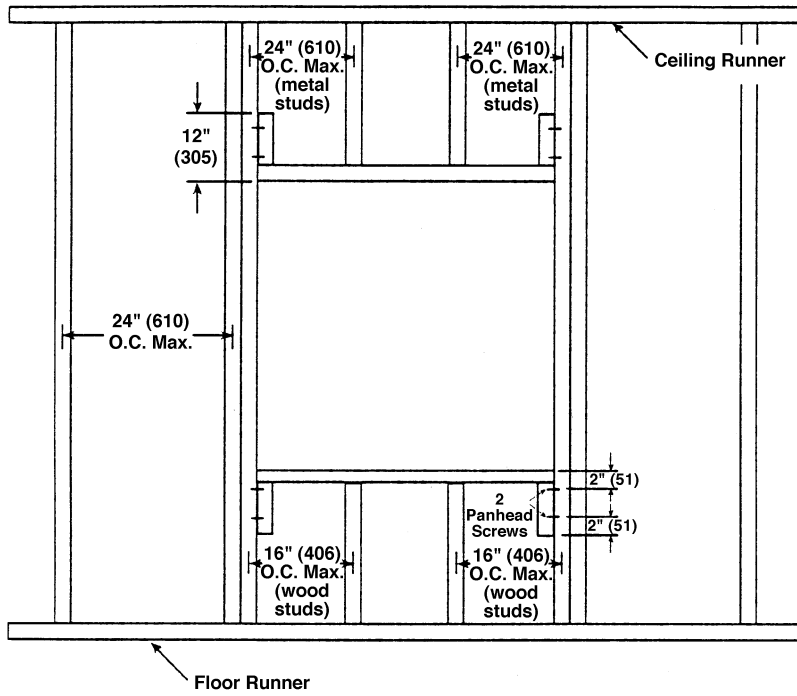

### INSTRUCTIONS

1. Frame wall openings as shown.
2. Double vertical studs are not required for openings 36" w x 36" h (914 x 914) or smaller.
3. All construction and fasteners must meet the requirements of the appropriate wall design and/or local codes.
4. Consult the authority having jurisdiction for other acceptable framing methods.

### NOTE:

The Metal Stud Construction and Wood Stud Construction figures at the bottom of the page depict mounting angles installed on both sides of the partition. A single angle may be sufficient. Refer to the instructions for single angle installation requirements.

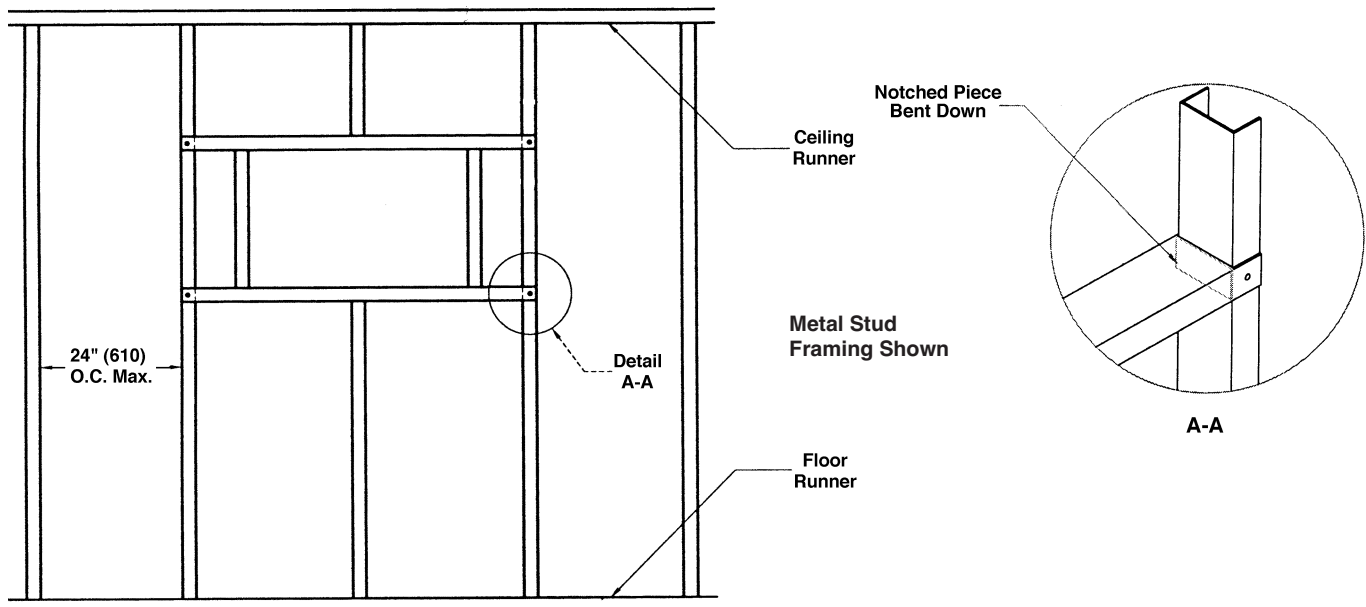

Figure 2

