

M9182, M9183, M9185, M9186 Modutrol IV™ Motors

SPECIFICATION DATA

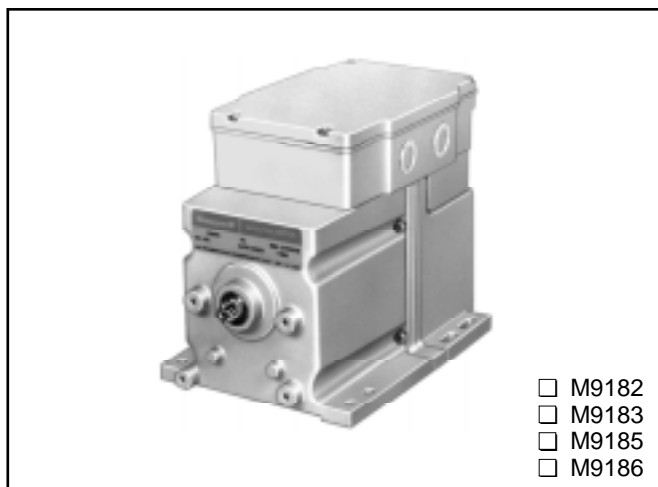

APPLICATION

M9182, M9183, M9185 and M9186 are proportioning spring return motors used to operate dampers and valves.

FEATURES

- Replaces M945A,D,F and M955 Motors.
- Rated for 60 lb-in. torque.
- Oil immersed motor and gear train for reliable performance and long life.
- Wiring box provides NEMA 3 weather protection.
- Quick-connect terminals standard—screw terminal adapter available.
- Adapter bracket for matching shaft height of older motors is standard with replacement motors.
- Integral auxiliary switches are available factory mounted, or can be field added to TRADELINE® models.
- Field addable interface modules can be mounted in wiring box to upgrade actuator to Series 70 (electronic) control.
- Auxiliary end shaft on TRADELINE® model can operate valve linkage. For use in normally open valve applications.
- Die-cast aluminum housing.



SPECIFICATIONS

TRADELINE® Models

TRADELINE® models are selected and packaged to provide ease of stocking, ease of handling, and maximum replacement value. TRADELINE® model specifications are the same as those of standard models, unless otherwise specified. TRADELINE® model is M9185D1004. TRADELINE® model has auxiliary switch cams.

Standard Models

M9182A,C,D,W
M9183G
M9185A,B,C,D,E
M9186G

Control Type
91 is Series 90

Power Rating
8 is high torque: 60 lb-in.

Output Drive
5 is spring return normally closed, dual-ended shaft
6 is spring return normally open, dual-ended shaft
2 is spring return normally closed, single-ended shaft
3 is spring return normally open, single-ended shaft

Suffix Letter
A: Fixed stroke (90° or 160°), No auxiliary switches
B: Fixed stroke (90° or 160°), 1 auxiliary switch
C: Fixed stroke (90° or 160°), 2 auxiliary switches
D: Adjustable stroke (90° to 160°), No auxiliary switches
E: Adjustable stroke (90° to 160°), 1 auxiliary switch
G: Fixed stroke (90° or 160°), No auxiliary switches, Electrically normally open (motor drives open, clockwise, when powered and control wiring not connected)
W: Fixed stroke (90° or 160°), 1 auxiliary switch

Electrical Ratings:

M9182, M9183, M9185, M9186	Voltage (V at 50/60 Hz)	Current Draw (A)	Power Consumption (W)
Without Transformer ^a	24	1.0	23
With Internal Transformer	120	0.28	28
	208	0.16	28
	240	0.14	28

^a Internal transformer can be field added.

Controller Type:

Series 90 Control Circuit: 135 ohm, Series 90 proportioning controller. Series 90 high or low limit controller with manual minimum position potentiometer (with a combined total resistance of up to 500 ohms) can also be used in the control circuit.

Motor Rotation:

M9182, M9185 Motors spring counterclockwise (as viewed from power end) to a closed position on power interruption. M9183, M9186 Motors spring clockwise to an open position on power interruption.

Stroke:

Fixed Stroke Models: 90° or 160°.
Adjustable Stroke Models: Can be set between 90° and 160°.

Timing:

Nominal 30 seconds for 90° stroke and 60 seconds for 160° stroke.

NOTE: M9182D1023 timing is 2 min. for 90° stroke, or 4 min. for 160° stroke. It contains on-off pulsing circuitry to achieve timing. Intermittent operation is normal.

Torque:

60 lb-in. (6.8 N•m).

Maximum Damper Rating:

B dim = 68 in. (1727 mm).

Dead Weight Load on Shaft:

Power or Auxiliary End: 200 lb (90.8 kg) maximum.
Maximum Combined Load: 300 lb (136 kg).
Auxiliary shaft not included on M9182, M9183 Motors.

Ambient Temperature Ratings:

Maximum: 150°F (66°C) at 25% duty cycle.
Minimum: minus 40°F (-40°C)

Crankshaft: 3/8 in. (9.5 mm) Square.

M9185, M9186 have double-ended shafts.
M9182, M9183 have single-ended shafts.

Dimensions:

See Fig. 1.

Underwriters Laboratories Inc. Listed:

File No. E4436, Guide No. XAPX.

Canadian Standards Association Certified:

General Listing File No. LR1620, Guide No. 400-E.

Auxiliary Switch Ratings (Amperes):

One Contact ^a	120V	240V
Full Load	7.2	3.6
Locked Rotor	43.2	21.6

^a 40 VA pilot duty, 120/240 Vac on opposite contact.

Accessories:

- ES650117 Explosion-proof Housing: Encloses motor for use in explosive atmospheres. Not for use with Q601, Q618, and Q455 Linkages. Order separately from Nelson Electric Co. Requires Honeywell 7617DM Coupling.
- Q607 External Auxiliary Switch: Controls auxiliary equipment as a function of motor position.
- Internal Auxiliary Switch Kits: Can be field-installed on TRADELINE® models.
- 220736A: One-switch Kit.
- 220736B: Two-switch Kit.
- Q605 Damper Linkage: Connects motor to damper. *Includes motor crank arm.*
- Q618 Linkage: Connects Modutrol motor to water or steam valve.
- Q601 Bracket and Linkage Assembly: Connects Modutrol motor to water or steam valve.
- Q100A,B Linkage: Connects Modutrol motor to butterfly valve. Requires adapter bracket packed with motor.
- Q209E,F Potentiometer: Limits minimum position of motor.
- Q68 Dual Control Potentiometer: Controls 1 to 9 additional motors.
- Q181 Auxiliary Potentiometer: Controls 1 or 2 additional motors.
- 221455A Infinitely Adjustable Crank Arm: Approximately 0.75 inch (19 mm) shorter than the 4074ELY Crank Arm. Can rotate through downward position and clear base of motor without requiring use of adapter bracket.
- 220741A Screw Terminal Adapter: Converts the standard quick-connect terminals to screw terminals.

- Transformers: Mounted internally, provide 24 Vac power to motor.
- 198162JA: 24 Vac; 50/60 Hz (for electrical isolation).
- 198162EA: 120 Vac; 50/60 Hz.
- 198162GA: 220 Vac; 50/60 Hz.
- 198162AA: 120/208/240 Vac; 50/60 Hz.
- Q7130A: Interface Module with selectable voltage ranges (4-7 Vdc, 6-9 Vdc, and 10.5-13.5 Vdc). Adapts motor to M71XX function.
- Q7230A: Interface Module, selectable voltage or current control, with adjustable null and span. Adapts motor to M72XX function; 4 to 20 mA or 2 to 10 Vdc.
- Q7330A: Interface Module, for W936 Economizer applications. Adapts motor to M73XX function.
- Q7630A: Interface Module, 14-17 Vdc control with minimum position capability. Adapts motor to M76XX function.
- 7617ADW Adjustable Crank Arm: approximately 0.75 in. (19 mm) shorter than the 7616BR Crank Arm.
- 4074BYK: Controls up to 6 M91XX motors in unison from one Series 90 Controller.
- 4074EAU: Drives 2 or 3 M91XX motors from a W973 Single-zone Logic Panel and W7100 Discharge Air Controller.
- 4074EDC: Drives one M91XX motor from a 4-20 mA controller.
- 4074EED: Drives up to 4 M91XX motors from a 4-20 mA controller.
- 221508A Resistor Board: Plugs onto quick-connects in wiring box of M91XX motor. Can be used in place of 4074BYK, EAU, EDC, or EED resistor kits (functions described above).

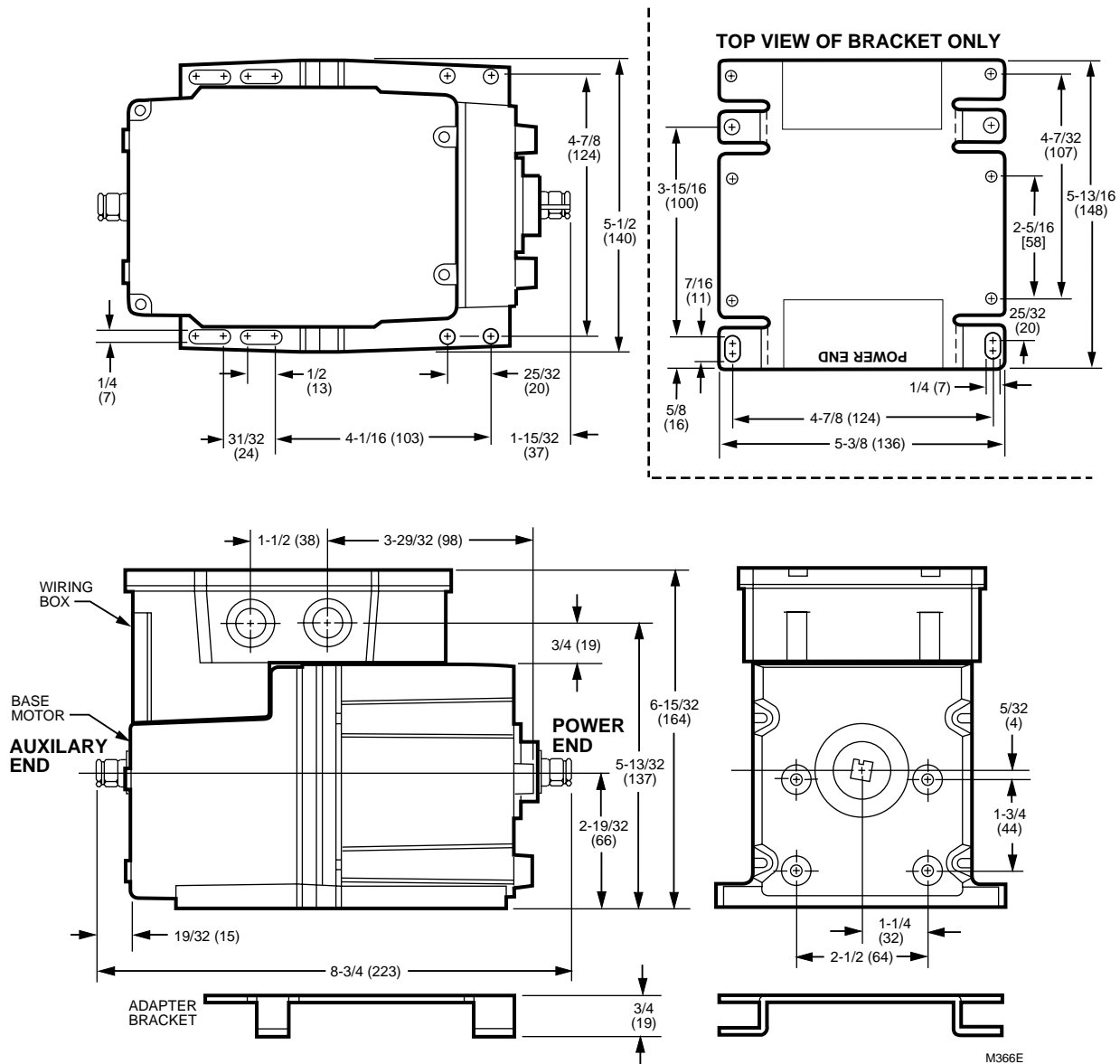

Fig. 1. Dimensions of M9185 and M9186 in in. (mm).

NOTE: M9182, M9183 do not have auxiliary shafts. All other dimensions are the same.

Home and Building Control

Honeywell Inc.
Honeywell Plaza
P.O. Box 524
Minneapolis MN 55408-0524

Home and Building Control

Honeywell Limited-Honeywell Limitée
155 Gordon Baker Road
North York, Ontario
M2H 2C9

Honeywell Asia Pacific Inc.

Room 3213-3225
Sun Hung Kai Centre
No. 30 Harbour Road
Wanchai
Hong Kong

Honeywell Latin American Division

Miami Lakes Headquarters
14505 Commerce Way Suite 500
Miami Lakes FL 33016

Honeywell Europe S.A.

3 Avenue du Bourget
B-1140 Brussels Belgium

Honeywell

Helping You Control Your World

