

INSTALLATION INSTRUCTIONS (D)FD35/OW, (D)FD35SS/OW AND (D)FD60/OW FIRE DAMPER 1½ HOUR UL CLASSIFIED RATING

APPLICATION

The DFD35/OW, DFD35SS/OW and DFD60/OW dynamic fire dampers are for use in dynamic (fans on) or static (fans off) systems. The FD35/OW, FD35SS/OW and FD60/OW static fire dampers are for use in static (fans off) systems only. Out of wall "OW" fire dampers are designed so that the leading edge of the damper frame can be up to 8" (203) out of the wall, partition or masonry floor. OW fire dampers may be used in fire resistance rating applications of less than 3 hours. OW fire dampers may be used for through penetrations or duct terminations where the damper cannot be installed within the wall or floor.

DYNAMIC FIRE DAMPERS

Use in Dynamic (fans on) or Static (fans off) Systems

(D)FD35/OW MAXIMUM UL CLASSIFIED SIZES –

Single section vertical and horizontal installation
36"w x 36"h (914 x 914)

(D)FD60/OW MAXIMUM UL CLASSIFIED SIZES –

Single section vertical installation
32"w x 36"h (813 x 914)
Single section horizontal installation
32"w x 36"h (813 x 914)
Multiple section vertical and horizontal installation
36"w x 36"h (914 x 914)

(D)FD35SS/OW MAXIMUM UL CLASSIFIED SIZES –

Single section vertical and horizontal installation
30"w x "h (762 x 914)
Multiple section vertical and horizontal installation
36"w x 36"h (914 x 914)

Dimensions shown in parentheses () indicate millimeters.

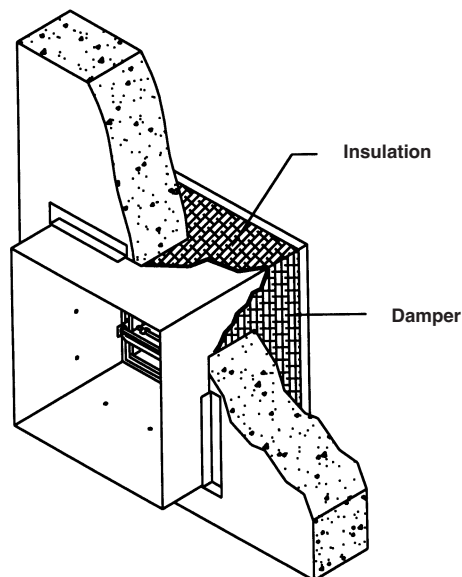

SEE COMPLETE MARKING
ON PRODUCT

California State Fire Marshal Listing No.

FD35/OW – 3225-0245:0005

FD35SS/OW – 3225-0245:0005

FD60/OW – 3225-0245:0004

1. Opening Clearance

Opening clearance for expansion is not required for the Out of Wall or Floor dampers. However, to accommodate for the sleeve and insulation thickness, the finished opening needs to be 1/2" (13) larger in width and height than the damper nominal size. For example a 24" x 20" (610 x 508) damper the finished opening should be minimum of 24 1/2" x 20 1/2" (622 x 521). The wallboard may be finished to enhance the appearance of the opening.

2. Damper Orientation

Dampers are designed to operate with blades running horizontally. Use "Mount With Arrow Up" label as a guide for proper damper orientation. The maximum the leading edge of the damper frame can be installed outside the wall:

Steel Stud or Masonry Walls: 8" (203)

Wood Stud Walls: 6" (152)

3. Insulation

Insulation shall be 1/4" (6) fiberfrax attached to all four sides of the damper and sleeve assembly (factory installed).

4. Damper Sleeve

Sleeve thickness must be equal to or thicker than the duct connected to it. Sleeve gage requirements are listed in the SMACNA Fire, Smoke and Radiation Damper Installation Guide for HVAC Systems and in NFPA90A. If a breakaway style duct/sleeve connection is not used, the Sleeve shall be a minimum of 16 gage (1.6) for dampers up to 36" (914) wide by 24" (610) high and 14 gage (1.9) for dampers exceeding 36" (914) wide by 24" (610) high. Damper sleeve shall not extend more than 6" (152) beyond the fire wall or partition unless damper is equipped with an actuator and/or factory installed access door. Sleeve may extend up to 16" (406) beyond the firewall or partition on sides equipped with actuator and/or factory installed access door. Sleeve shall terminate at both sides of wall within dimensions shown.

5. Fasteners

a. Fasteners spacing to attach the mounting angles or damper sleeve to the wall or floor and mounting angles to the damper sleeve, minimum of 1 fastener per side..

Steel Stud or Masonry Walls: 12" (305) c-to-c

Wood Stud Walls: 6" (152) c-to-c

b. Fastener to attach mounting angles to the wall or floor.

In masonry walls or floor use minimum #10 self-tapping concrete anchors. Screw must engage the wall or floor a minimum of 1 1/2" (38).

In metal stud use minimum #10 (M5) screws. Screw must engage the metal stud a minimum of 1/2" (13).

In wood stud use minimum #10 (M5) screws. Screw must engage the wood a minimum of 3/4" (19).

c. Fastener to attach mounting angles to the damper sleeve. Mounting angles to be connected to the damper sleeve with minimum of number 10 (M5) screws on bolts, tack welds or 1/2" (13) long welds.

6. Mounting Angles

a. Mounting angles shall be a minimum of 1 1/2" x 1 1/2" x 20 gage steel (38 x 38 x 1.0). Ruskin "FAST" angle or only a single conventional mounting angle is required on side opposite of the damper and fastened to the damper sleeve and wall or floor. Do not weld or fasten conventional angles together at the corners of damper.

b. Optional installation where the damper is larger than the opening in the wall, the mounting angle is not required and the damper is to be fastened to the wall from the inside of the damper sleeve. Mounting angles may be used but are not required.

c. Optional installation where the damper is larger than the opening in the floor and the damper is mounted on the top side of the floor, the mounting angle is not required and the damper is to be fastened to the floor from the inside of the damper sleeve. Mounting angles may be used but are not required.

d. Optional installation where the damper is larger than the opening in the floor and the damper is mounted on the bottom side of the floor, 1 1/2" x 1 1/2" x 20 gage steel (38 x 38 x 1.0) mounting angle is required on the top side of the floor fastened to the damper sleeve and floor.

7. Duct/Sleeve Connection

a. Break-away Duct/Sleeve Connection

Rectangular ducts must use one or more of the connections depicted below:

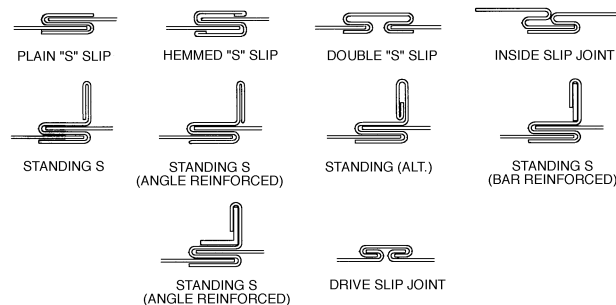

A maximum of two #10 (M5) sheet metal screws on each side and the bottom, located in the center of the slip pocket and penetrating both sides of the slip pocket may be used. Connections using these slip joints on the top and bottom with flat drive slips up to 20" (508) long on the sides may also be used.

b. Round and Oval Break-away Connection

Round and flat oval break-away connections must use either a 4" (102) wide drawband or #10 (M5) sheet metal screws spaced equally around the circumference of the duct as follows:

- Duct diameters 22" (559) and smaller – maximum 3 screws.
- Duct diameters over 22" (559) and including 36" (914) – maximum 5 screws.
- Duct diameters over 36" (914) and up to and including 191" (4851) total perimeter – maximum 8 screws.

For flat oval ducts, the diameter is considered the largest (major) dimension of the duct. These connections are depicted in the SMACNA Fire, Smoke, and Radiation Damper Installation Guide.

Note: When optional sealing of these joints is desired, the following sealants may be applied in accordance with the sealant manufacturer's instructions:

Design Polymeric – DP 1010

Precision – PA2084T

Hardcast, Inc. – Iron Grip 601

Eco Duct Seal 44-52

c. Flanged Break-away Style Duct/Sleeve Connection

Flanged connection systems manufactured by Ductmate, Nexus or Ward and roll-formed flanged connection by TDF and TDC are approved breakaway connections. Connection between manufactured systems may be used with metal or plastic cleats, Butyl or neoprene gaskets, and/or bolted or non-bolted corners. See Flanged System Breakaway Connections Supplement for detail.

d. Non-Break-away Duct/Sleeve Connection

If other duct/sleeve connections are used, the sleeve shall be a minimum of 16 gage (1.6) for dampers up to 36" (914) wide x 24" (610) high and 14 gage (2.0) for dampers larger than 36" (914) wide x 24" (610) high.

8. Installation and Maintenance

Install dampers so they are square and free from racking. Do not compress or stretch damper frames into the duct or opening. Dampers must be maintained, cycled, and tested in accordance with local codes and recognized standards or publications like: NFPA 80, 90A, 101, etc.

VERTICAL INSTALLATION

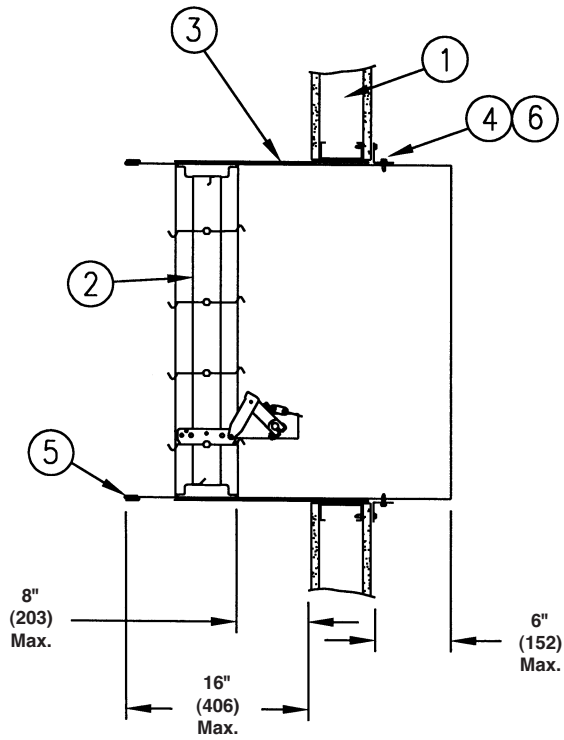

ITEM	DESCRIPTION
1.	Wall: steel or wood stud or masonry
2.	Damper
3.	1/4" (6) thick insulation (Factory Installed)
4.	Fasteners – See Note #5
5.	Duct/Sleeve connection
6.	Mounting Angles – See Note #6
7.	Grille (By Others) Optional

OPTIONAL VERTICAL INSTALLATION

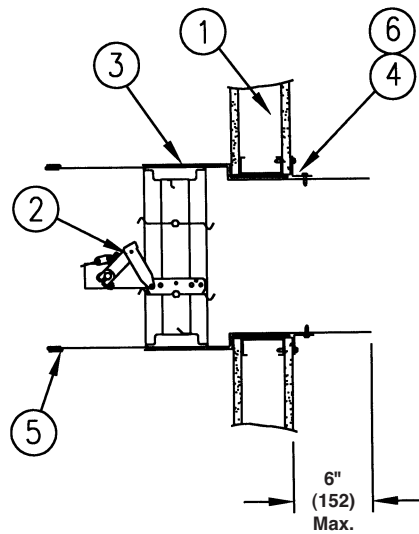
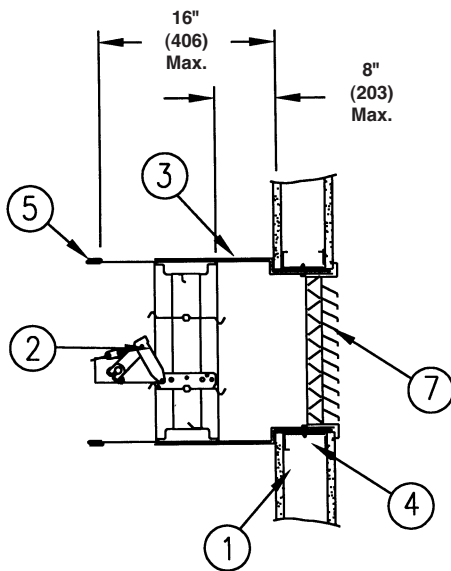

HORIZONTAL INSTALLATION

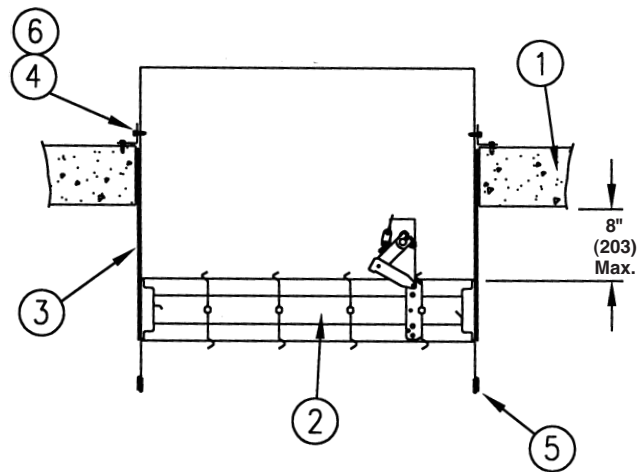

ITEM	DESCRIPTION
1.	Wall: steel or wood stud or masonry
2.	Damper
3.	1/4" (6) thick insulation (Factory Installed)
4.	Fasteners – See Note #5
5.	Duct/Sleeve connection
6.	Mounting Angles – See Note #6
7.	Grille (By Others) Optional

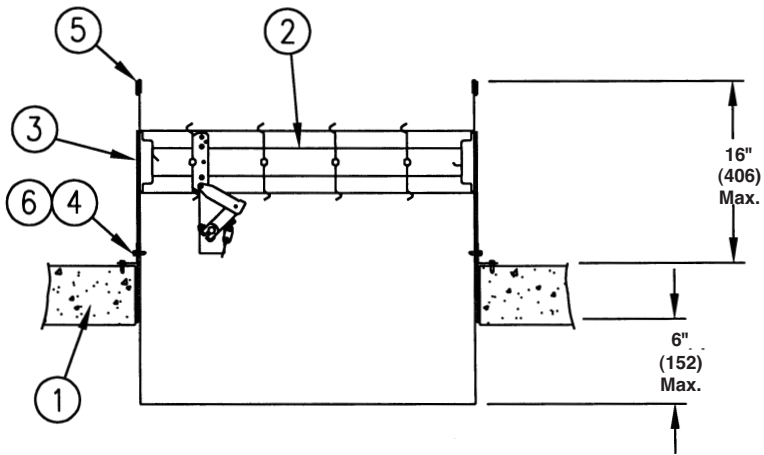

OPTIONAL HORIZONTAL INSTALLATION

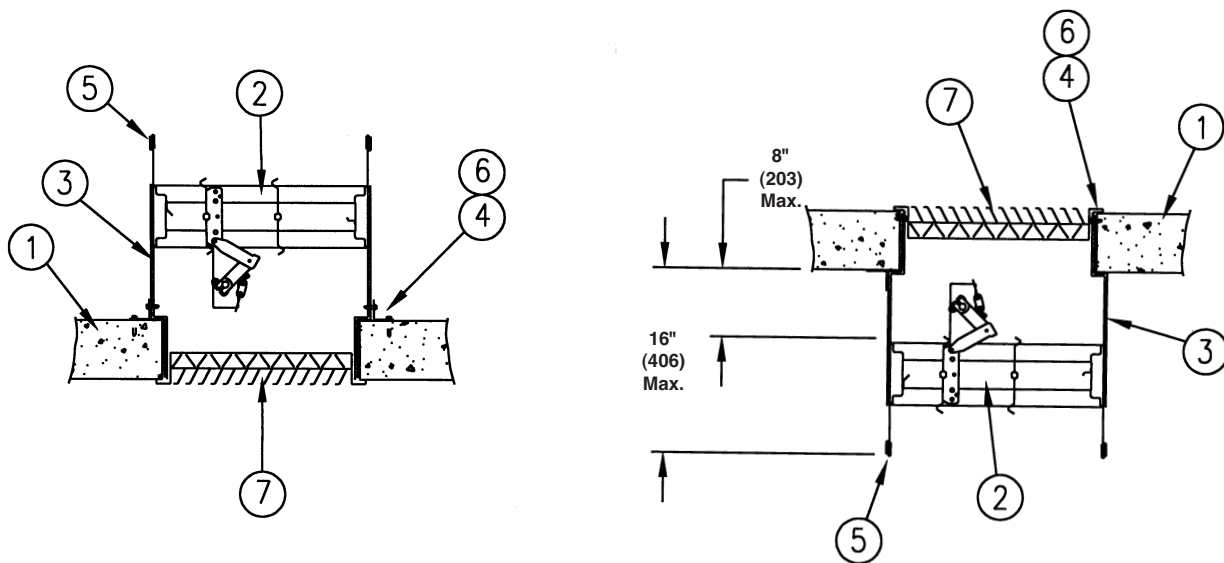

RECOMMENDED FRAMING FOR OPENINGS IN WOOD AND METAL STUD WALLS

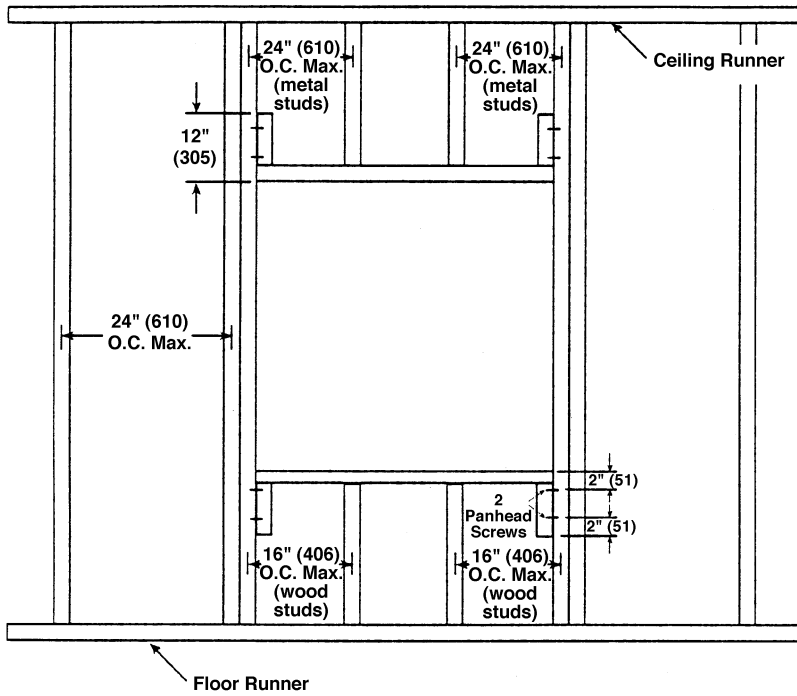

Figure 1

INSTRUCTIONS

1. Frame wall openings as shown in figure 1 or 2.
2. Double vertical studs are not required for openings 36" w x 36" h (914 x 914) or smaller.
3. All construction and fasteners must meet the requirements of the appropriate wall design and/or local codes.
4. Consult the authority having jurisdiction for other acceptable framing methods.

NOTE:

The Metal Stud Construction and Wood Stud Construction figures at the bottom of the page depict mounting angles installed on both sides of the partition. A single angle may be sufficient. Refer to the instructions for single angle installation requirements.

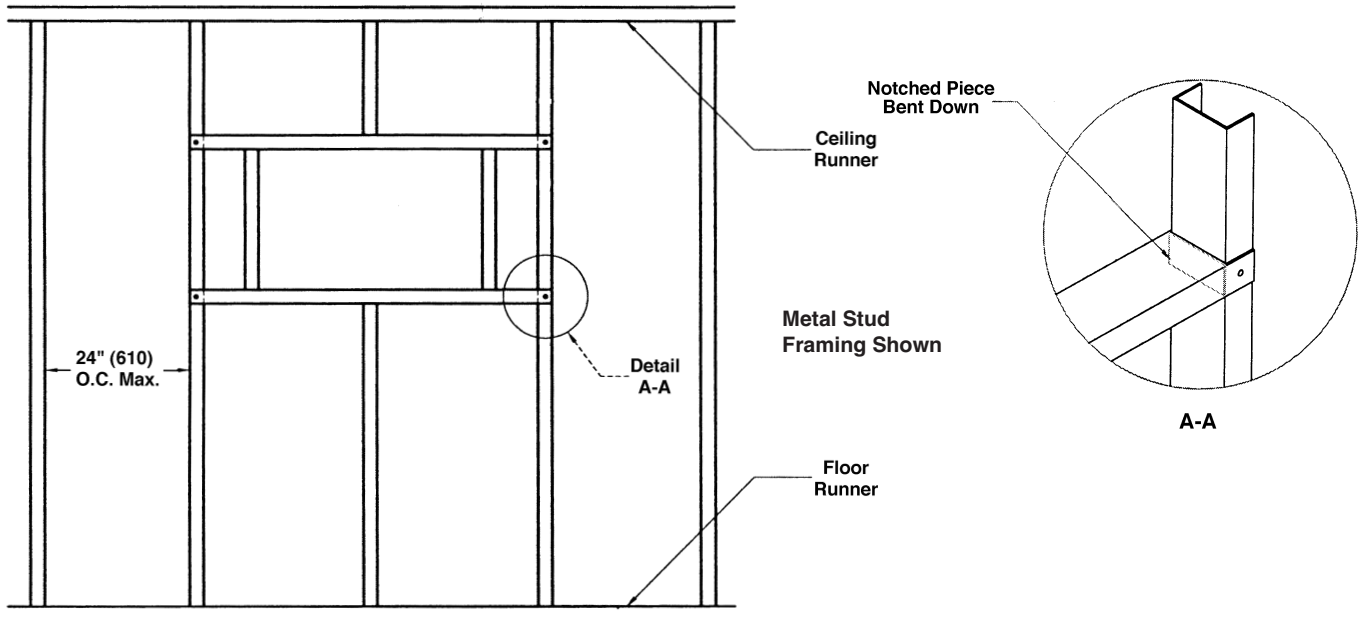
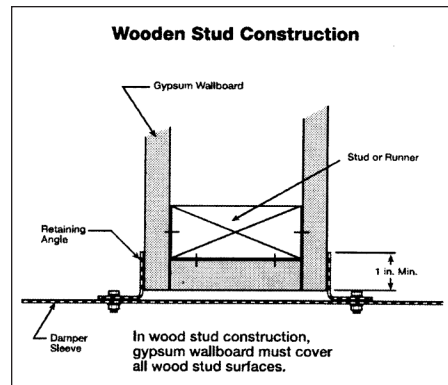
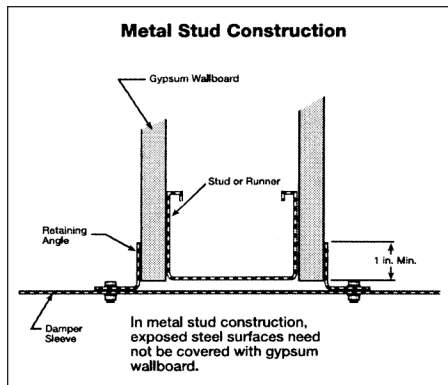

Figure 2



RUSKIN®

3900 Dr. Greaves Rd.
Kansas City, MO 64030
(816) 761-7476
FAX (816) 765-8955
www.ruskin.com