

WMRS-25 WAL-MART SPECIAL ROUND MANUAL BALANCING DAMPER

STANDARD CONSTRUCTION

FRAME

- 4" - 20" (102 - 508), 20 gage (.91) galvanized steel 10" (254) long.
- 22" - 30" (559 - 762), 20 gage (.91) galvanized steel 10" (254) long with stiffener ring.
- 32" - 40" (813 - 1016), 16 gage (1.6) galvanized steel 10" (254) long.

BLADES

- 4" - 20" (102 - 508), 20 gage (.91) galvanized steel.
- 22" - 30" (559 - 762), 16 gage (1.6) galvanized steel stiffened as required.
- 32" - 40" (813 - 1016), 10 gage (3.5) galvanized steel stiffened as required.

AXLES

- 4" - 20" (102 - 508), 3/8" (10) square axle plated steel full length.
- 22" - 30" (559 - 762), 1/2" (13) square axle plated steel full length.
- 32" - 40" (813 - 1016), 3/4" (19) diameter axle plated steel full length.

CONTROL SHAFT/HAND QUADRANT

- 4" - 20" (102 - 508) 3/8" (10) square axle shaft extending through 2" (51) standoff bracket and factory mounted locking hand quadrant.
- 22" - 30" (559 - 762) 1/2" (13) square axle shaft extending through 2" (51) standoff bracket and factory mounted locking hand quadrant.
- 32" - 40" (813 - 1016) 3/4" (19) diameter shaft extending through 2" (51) standoff bracket and factory mounted locking hand quadrant.

BEARINGS

- 4" - 20" (102 - 508) – molded synthetic.
- 22" - 30" (559 - 762) – Ventlok 607 end bearing.
- 32" - 40" (813 - 1016) – 3/4" (19) stainless steel sleeve bearing.

FINISH

Mill galvanized.

MAXIMUM VELOCITY

1500 FPM (457m/min.)

MAXIMUM TEMPERATURE

250°F (-121°C).

DAMPER SIZES

- 4", 5", 6", 7", 8", 9", 10", 12", 14", 16", 18", 20", 22", 24", 26", 28", 30", 32", 34", 36", 38", 40" (102, 127, 152, 178, 203, 229, 254, 305, 356, 406, 457, 508, 559, 610, 660, 711, 762, 813, 864, 914, 965, 1016) diameters.

No variations are allowed for this model.

Dimensions in parenthesis () indicate millimeters.

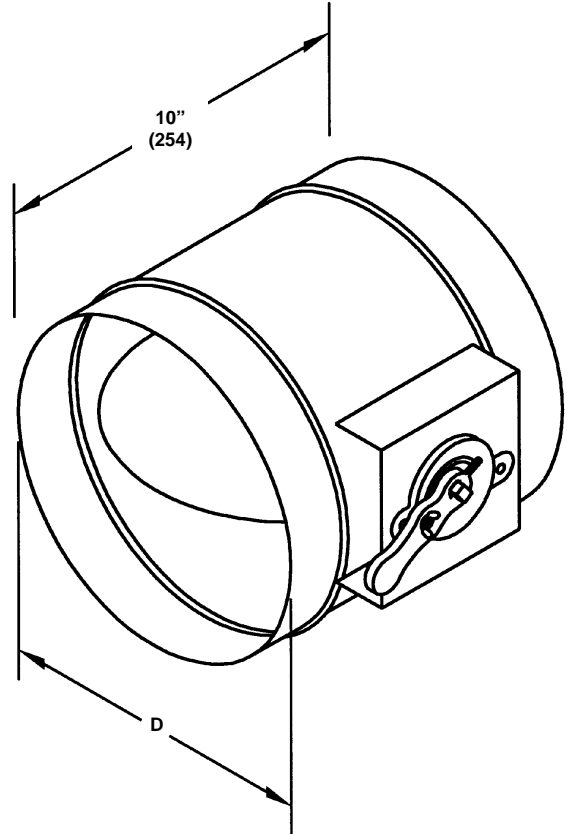

*Unit furnished approximately 1/8" (3) smaller than given dimensions.

QTY.	D* – Diameter	VARIATIONS
JOB CONTRACTOR		LOCATION