

INSTALLATION INSTRUCTIONS

MODEL FSDR25C ROUND CORRIDOR DAMPER

CLASSIFIED UL555 1 HOUR UL555S CLASS 1

APPLICATION

The FSDR25C is a true round corridor damper designed for installation in the ceiling penetration of "tunnel type" corridors constructed from metal studs. The FSDR25C is designed to fail close upon loss of power.

DAMPER SIZES

6" (152), 8" (203), 10" (254) and 12" (305) diameter.

GENERAL INSTALLATION

1. Ceiling Construction

The minimum ceiling partition construction will consist of metal studs on 24" (610) center to center. UL classified $\frac{5}{8}$ " (16) gypsum will be attached to the studs with $1\frac{1}{8}$ " (29) drywall screws at 12" (305) centers.

2. Opening Clearance

A square opening in metal stud ceiling partition shall be a minimum of 1" (25) and a maximum of $2\frac{1}{2}$ " (64) larger than the damper diameter.

THE RETAINING "CINCH" PLATE MUST OVERLAP THE OPENING A MINIMUM OF $\frac{1}{2}$ " (13).

3. Damper Sleeve

The sleeve is integral to the damper and shall be of equal to or heavier than the gage of the duct as described in NFPA90A and as defined by the appropriate SMACNA duct construction standard.

4. Damper Orientation

The leading edge of the blade in the closed position must be within the plane of the ceiling partition.

5. Retaining "Cinch" Plates

DO NOT PLACE CINCH PLATES IN GROOVE

The retaining "cinch" plates are designed to grab and hold the sleeve while mounting flush against the ceiling partition retaining the damper securely in the opening. The plates must overlap the opening a minimum of $\frac{1}{2}$ " (13) (see "Cinch" Plate section).

The "Cinch" plates are fastened to the wall or floor according to the following:

- Metal Stud Ceiling Partition – "Cinch" plate required on both sides of the partition fastened to the partition by engaging the metal stud a minimum of $\frac{1}{2}$ " (13) with a #10 screw.

6. Duct/Sleeve Connections

Round break-away connections must be used. Either a 4" (102) wide drawband or #10 sheet metal screws spaced equally around the circumference of the ducts as follows:

- Duct diameters 22" (559) and smaller – 3 screws.

Note: When optional sealing of these joints is desired, the following sealants may be applied in accordance with the sealant manufacturer's instructions:

Hardcast, Inc. - Iron Grip 601

Precision - PA2084T

ECO Duct Seal 44-52

Design Polymeric – DP 1010.

7. Actuator Connections

Electric and pneumatic actuators are to be connected in accordance with wiring and piping diagrams developed in compliance with applicable codes, ordinances and regulations.

8. Installation and Maintenance

To ensure optimum operation and performance, the damper must be installed so it is square and free from racking. Each fire/smoke damper should be maintained, cycled and tested at intervals not less than every six months and in accordance with the latest editions of NFPA 90A, 92A, UL864, local codes and in accordance with actuator manufacturer recommendations. Care should be exercised to ensure that such tests are performed safely and do not cause system damage.

Dimensions shown in parentheses () indicate millimeters.

INSTALLATION SUPPLEMENTS

Refer to the appropriate Ruskin installation instructions supplements for additional information or special requirements:

- TS150 FireStat for "Reopenable" Combination Fire and Smoke Dampers
- SP100 Switch Package
- EFL Electric Resettable Link
- EFL/SP100 Electric Resettable "Fuse" Link and Switch Package
- PFL Pneumatic Fuse Link

Dimensions shown in parentheses () indicate millimeters.

RETAINING "CINCH" PLATES

RETAINING "CINCH" PLATE

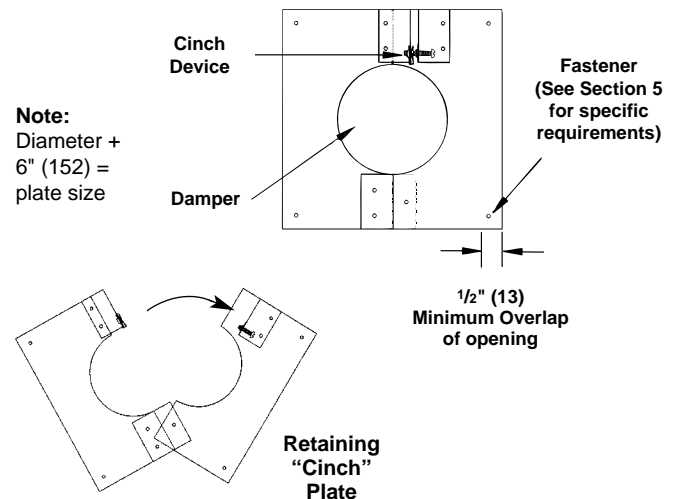

SEE COMPLETE MARKING
ON PRODUCT

GENERAL INSTALLATION

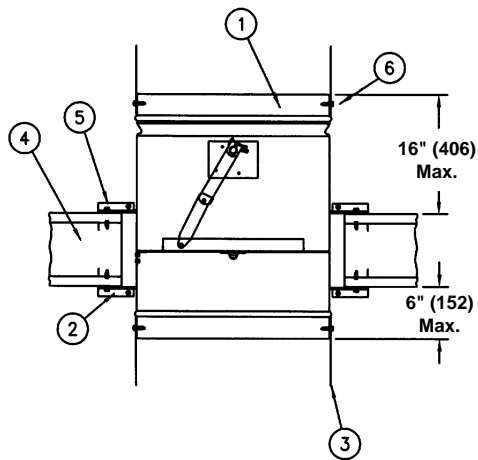

Figure 1

- | ITEM | DESCRIPTION |
|------|--|
| 1. | FSDR25C Round Corridor Damper |
| 2. | Retaining "cinch" Plate, 20 ga. steel (one plate required on each side of ceiling partition) |
| 3. | Duct |
| 4. | Corridor ceiling partition |
| 5. | #10 screw |
| 6. | Duct/Sleeve Connection |
- Note:**
Damper can be installed with actuator on top of or below the ceiling partition.

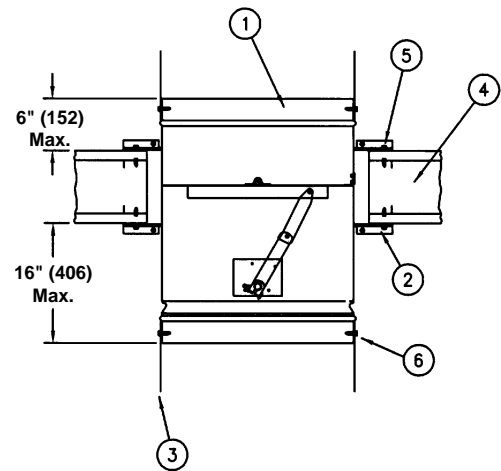
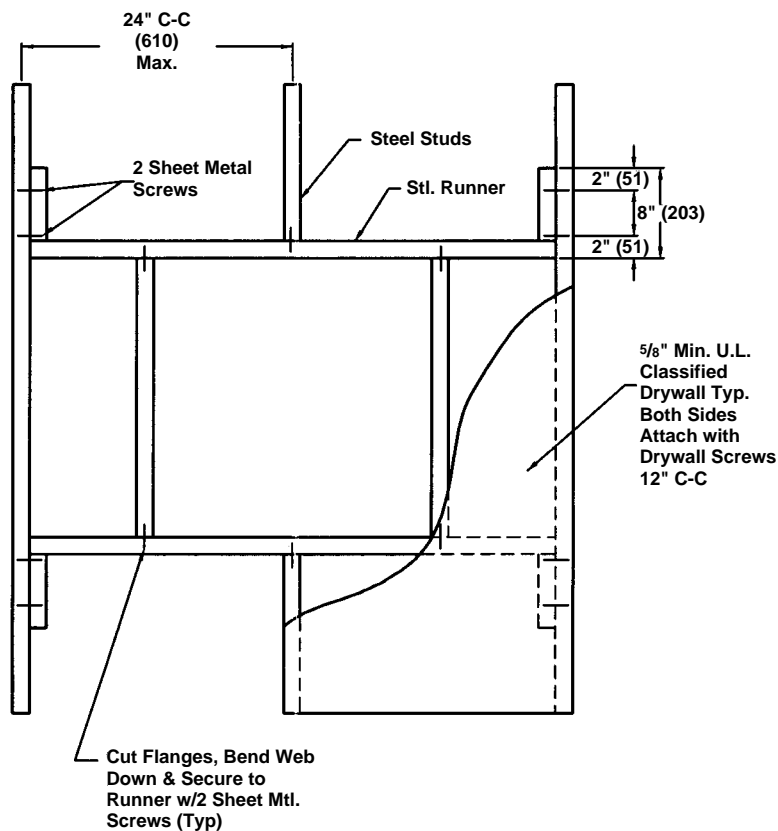

Figure 2

FRAMING DETAILS

Steel Stud Construction



RUSKIN®

3900 Dr. Greaves Rd.
Kansas City, MO 64030
(816) 761-7476
FAX (816) 765-8955
www.ruskin.com