

SD60-V SMOKE DAMPER UL555S LEAKAGE CLASS 2

APPLICATION

The SD60-V is the most versatile smoke damper in the industry. It is approved for installation with blades running either horizontally or vertically and is the best performing damper in the industry on sizes over 32" (813) wide. The SD60-V is the perfect choice for applications where ducts run side by side and there is no room for actuators on the side of the damper. The high strength one-piece airfoil blades insure lowest resistance to airflow with velocities up to 4,000 fpm (20.3 m/s) and 8" w.g. (2 kPa). The SD60V may be installed vertically (with blades running horizontal) or horizontally and is rated for airflow and leakage in either direction.

UL555S LEAKAGE RATING

Leakage class 2

OPERATIONAL RATING

Velocity: up to 4000 fpm (20.3 m/s)
Pressure: up to 8 in. wg (2 kPa)
Temperature: 250°F (121°C) or 350°F (177°C)

OPERATION OPTIONS

Fail Position: Closed or Open

STANDARD CONSTRUCTION

FRAME

5" x 16 gage (127 x 1.6) galvanized, single piece, hat-shaped channel, structurally superior to 13 (2.3) gage channel frame.

BLADES

One-piece airfoil, 6" (152) wide and 14 (2.0) gage galvanized steel equivalent thickness. Blades are approximately 6" (152) on center.

BEARINGS

Stainless steel sleeve, pressed into frame.

JAMB SEALS

Stainless steel, flexible metal compression type.

BLADE SEALS

Silicone edge type, mechanically fastened to the blade edge, for smoke seal to 450°F (232°C)..

LINKAGE

Concealed in frame.

DAMPER SIZES

Sizes listed below are for ratings of 2000 fpm (10.2 m/s) and 4 in. wg (1 kPa). See page 3 for extended operational ratings.

MINIMUM SIZE

6"w x 8"h (152 x 203).

MAXIMUM SIZE

Single Section – 48"w x 36"h (1219 x 914).

OPTIONS

- **FM Approvals** as Specification Tested Product.
- **DSDP/DSDN Duct Smoke Detector** (Flow rated or No-Flow).
- **SP100 Switch Package** to remotely indicate damper blade position.
- **Sleeves** of various lengths and gages.
- **MCP Control Panels** for test purposes or smoke management systems.
- **Actuators** of various types: electric or pneumatic.

NOTES

1. Damper are furnished approximately 1/4" (6) smaller than given opening dimensions.
2. Dimensions shown in parentheses () indicate millimeters.

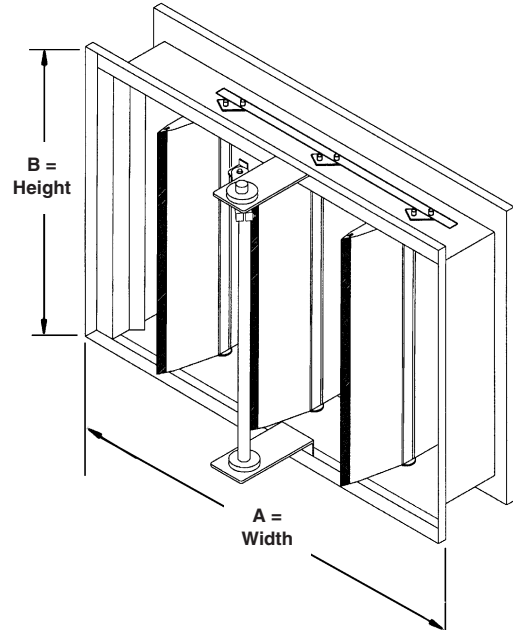

Model SD60-V meets the requirements for smoke dampers established by:

- **National Fire Protection Association NFPA Standards** 80, 90A, 92A, 92B and 101
- **ICC International Building Codes**
- **CSFM California State Fire Marshal Fire Damper Listing** (#3225-245:102 and Smoke Damper Listing (#3230-245:110)
- **New York City** (BSA Listing #176-82-SM)



SEE COMPLETE
MARKING
ON PRODUCT

UL555 Classification R5531

FM Approvals

Specification Tested Product
(Option)

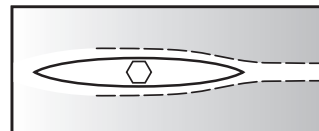

Ruskin Airfoil Blade



AMCA LICENSED AIR PERFORMANCE DATA



Ruskin Company certifies that the SD60-V shown hereon is licensed to bear the AMCA Seal. The ratings shown are based on tests and procedures performed in accordance with AMCA Publication 511 and comply with the requirements of the AMCA Certified Ratings Program. The AMCA Certified Ratings Seal applies to air performance for the SD60-V.

To determine the AMCA Licensed air performance:

Locate the applicable feet per minute face velocity on the bottom of the velocity vs. pressure drop chart below. Move up the chart to the most appropriate size damper line. From the intersection point, move left to determine the pressure drop on the left side of the chart.

For other damper sizes refer to **Air Performance Data For All Fire and Smoke Dampers** spec sheet.

VELOCITY vs. PRESSURE DROP

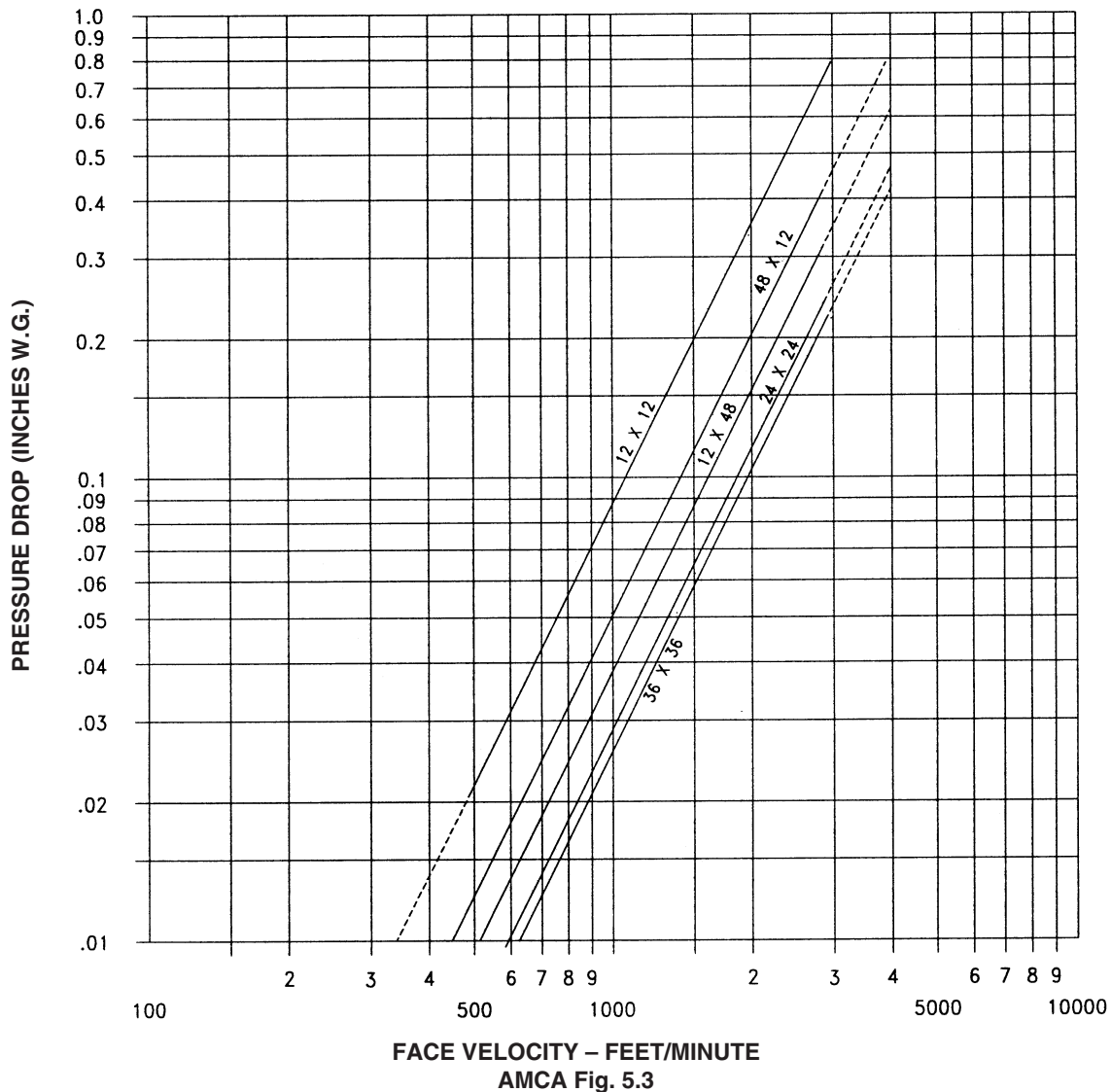

EXTENDED OPERATIONAL RATINGS

EXTENDED RATINGS FOR FAIL CLOSE

SIZE	STATIC PRESSURE	TEMPERATURE
2,000 FPM (10.2 m/s)		
48" x 36" (1219 x 914)	4" (102) w.g. (1 kPa)	350°F (177°C)
32" x 30" (813 x 762)	6" (152) w.g. (1.5 kPa)	250°F (121°C)
24" x 24" (610 x 610)	8" (203) w.g. (2 kPa)	250°F (121°C)
3,000 FPM (15.2 m/s)		
36" x 32" (914 x 813)	4" (102) w.g. (1 kPa)	250°F (121°C)
32" x 32" (813 x 813)	4" (102) w.g. (1 kPa)	350°F (177°C)
32" x 30" (813 x 762)	6" (152) w.g. (1.5 kPa)	250°F (121°C)
24" x 24" (610 x 610)	8" (203) w.g. (2 kPa)	250°F (121°C)
4,000 FPM (20.3 m/s)		
24" x 24" (610 x 610)	8" (203) w.g. (2 kPa)	250°F (121°C)

The UL555S Test Standard requires all smoke dampers to prove their operation (Close to Open and Open to Close) against heated air flow with minimum temperature of 250°F (121°C), minimum velocity of 2,000 feet per minute (10.2 m/s) and minimum static pressure of 4 inches of water (1 kPa). UL555S extended ratings allow the temperature to be increased at 100°F (37.8°C), 2 inches of water (0.5 kPa) and 1000 feet per minute (5.1 m/s) increments. The SD60-V smoke damper exceeds the minimum UL555S requirements on selected sizes. See chart for sizes and ratings. **Consult Ruskin for the appropriate actuator model and quantities.**

EXTENDED RATINGS FOR FAIL OPEN

SIZE	STATIC PRESSURE	TEMPERATURE
2,000 FPM (10.2 m/s) Fail Open Operation		
48" x 36" (1219 x 914)	4" (102) w.g. (1 kPa)	250°F (121°C)
3,000 FPM (15.2 m/s)		
36" x 32" (914 x 813)	6" (152) w.g. (1.5 kPa)	250°F (121°C)
4,000 FPM (20.3 m/s)		
24" x 24" (610 x 610)	8" (203) w.g. (2 kPa)	250°F (121°C)

TYPICAL ACTUATOR MOUNTING

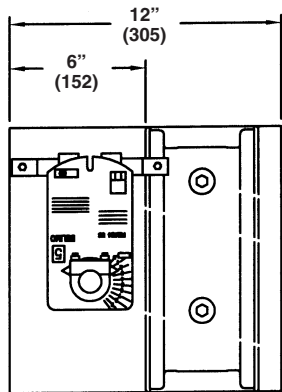

Multiple Section with Side Plate

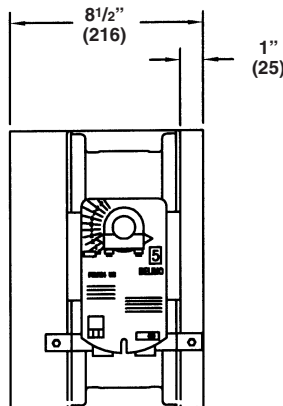

Single Section with Side Plate

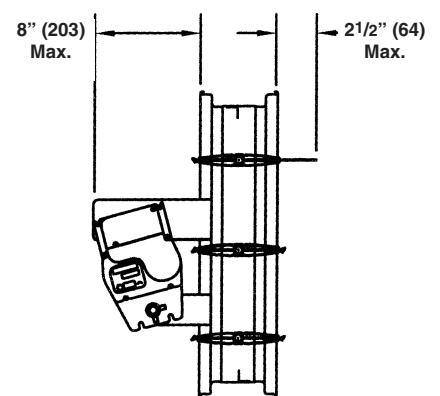

Typical Internal Mount

ACTUATOR REQUIREMENTS

- UL555S requires that all smoke dampers have factory mounted actuators in order to bear the UL label.
- Smoke dampers larger than single section may require multiple actuators. See "Smoke Damper Multiple Section Detail" spec sheet for details.
- Ruskin's smoke dampers are UL555S labeled with either electric or pneumatic actuators mount internal (in air stream) or external (out of air stream).
- Smoke dampers utilizing multiple actuators must have all actuators **field** wired to a common point for simultaneous closure. All field wiring shall be in accordance with applicable codes, ordinances and regulations.

SLEEVE TRANSITION DIMENSIONAL INFORMATION

DUCT TRANSITION CONNECTIONS

SD60-2 dampers may be supplied with Round, Oval and Rectangular duct connections.

Style	Description
CR	Round Sealed (Medium Pressure)
WR	Round Welded (High Pressure)
C	Rectangular Sealed (Low and Medium Pressure)
WC	Rectangular Welded (High Pressure)
CO	Oval Sealed (Medium Pressure)
WO	Oval Welded (High Pressure)

The square damper size will be 2" (51) larger in width and height than the round, oval or rectangular duct size ordered.

MINIMUM and MAXIMUM SIZES

Round Transitions

Minimum 4" (102) diameter
Maximum – 34" (864) diameter

Rectangular and Oval Transitions

Minimum 6" w x 4" h (152 x 102) 4" w x 6" h (102 x 152)
Maximum – 46" w x 34" (1168 x 864)

Consult Ruskin for other available styles and sizes.

Note: For medium pressure units (Styles CR, C and CO) the collar extends 1 1/2" (38) beyond the sleeve length and for low pressure and high pressure units (Styles R, WR, WC and LO) the collar extends 2 1/2" (64) beyond the sleeve length.

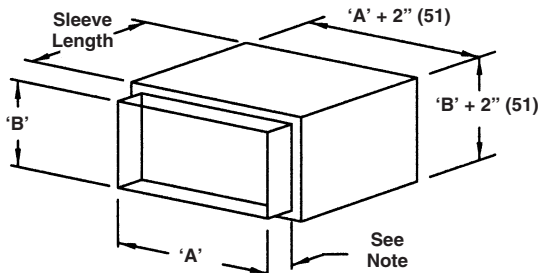

Style C and WC

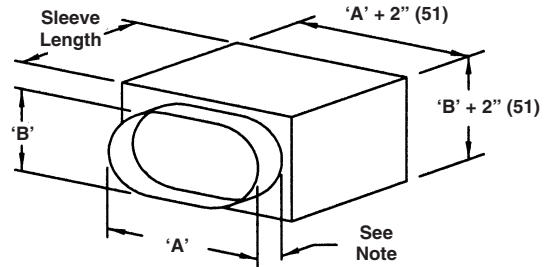

Style LO, CO and WO

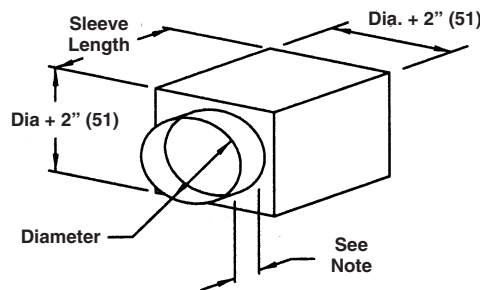

Style R, CR and WR

SUGGESTED SPECIFICATION

Smoke dampers meeting or exceeding the following specifications shall be furnished and installed at locations shown on plans or as described in schedules. AMCA Certified smoke dampers shall meet the requirements of NFPA80, 90A, 92A and 92B and shall be classified as Smoke Dampers in accordance with the latest version of UL555S. The leakage rating under UL555S shall be Leakage Class 2. Smoke dampers shall be produced in an ISO 9001 certified factory.

Damper frame, where size permits, shall be constructed using the UniFrame Design Concept (UDC) and shall be minimum 16 (1.6) gage galvanized steel formed into a structural hat channel structurally superior to 13 (2.3) gage channel frame. Top and bottom frame members on dampers less than 13" (330) high shall be low profile design to maximize the free area of these smaller dampers. Damper blades shall be single piece airfoil shaped with 14 (2.0) gage equivalent thickness and shall run vertically. Blade edge seals shall be inflatable silicone mechanically locked into blade edge. Jamb seals shall be stainless steel compression type. Bearings shall be stainless steel, permanently lubricated sleeve type turning in an extruded hole in the frame for maximum life.

Smoke dampers and their actuators shall be qualified in accordance with UL555S to an elevated temperature of 250°F (121°C) or 350°F (177°C) depending upon the actuator. Appropriate electric or pneumatic actuators (**specifier select one**) shall be installed by the damper manufacturer at time of damper fabrication. Electric actuators, factory installed on dampers, shall have been tested for prolonged periods of holding (minimum 1 year with no evidence of reduced spring return performance). Each damper shall be rated for leakage and airflow in either direction through the damper. In addition to the leakage ratings already specified, the dampers shall be AMCA licensed for Air Performance.

<Optional FM Approvals Specification>

Each fire damper shall be listed in Factory Mutual (FM) Approvals Specification Tested Product and labeled accordingly.

Smoke dampers shall be Ruskin model SD60-V.

(Consult www.Ruskin.com for electronic version of this "Quick" spec as well as for complete 3-part CSI *MasterFormat* Specification).

RUSKIN®

3900 Dr. Greaves Rd.
Kansas City, MO 64030
(816) 761-7476
FAX (816) 765-8955
www.ruskin.com

Printed on recycled paper
using vegetable based inks