

## GPT150, GPT151 AND ZG-X40 TRANSFORMERS FOR COMMERCIAL CONTROL DAMPER

**CONSTRUCTION**

Copper windings.

**CONNECTIONS**

Screw Mounted Terminals.

**APPROVALS**

UL Class 180°C.

Temperature 239°F (115°C) temperature rise at a maximum ambient of 104°F (40°C).

Rated for 50/60 Hertz.

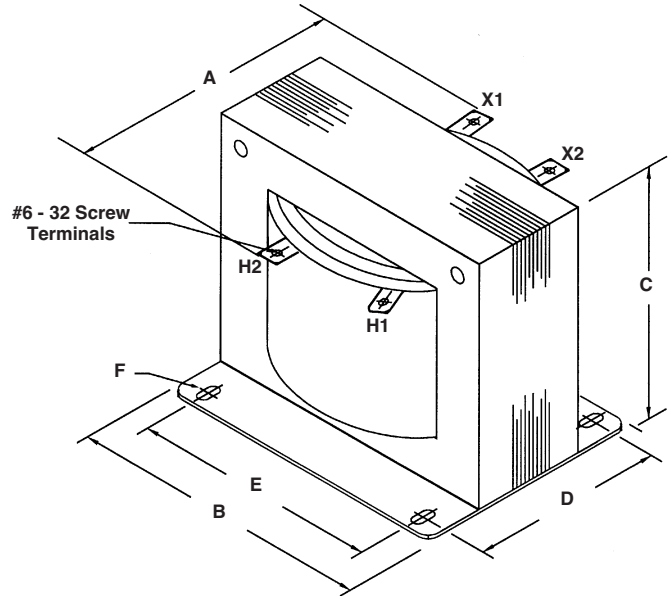

Dimensions shown in parenthesis ( ) indicate millimeters.  
Unit furnished approximately 1/4" (6) smaller than given opening dimensions.

Model	Primary Voltage	Secondary Voltage	kVA Cap.	A	B	C	D	E	F	Primary Max. Amps	Secondary Max. Amps
GPT-150	480/240	120	.150	3.90	3.75	3.13	2.63	3.13	.203X.375	.3125/.625	1.25
GPT-151	277	120	.150	3.90	3.75	3.25	2.63	3.13	.203X.375	0.55	1.25

**CONSTRUCTION**

Copper windings.

**CONNECTIONS**

#18 gage wire leads 6 1/2" (165) long.

**APPROVALS**

UL 1568, CSA 22.25 #66.

Rated for 50/60 Hz.

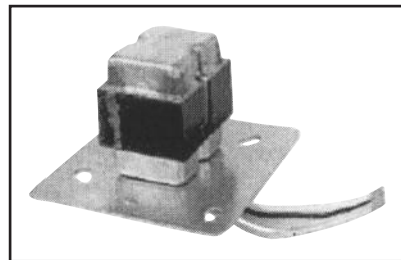

**Dimensions**

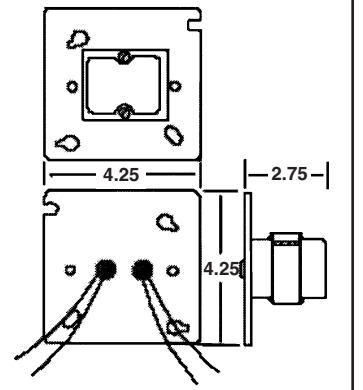

Model	Primary Voltage	Secondary Voltage	kVA Cap.
ZG-X40	120	24	.40

**Wiring Diagram**

