

FSD60OW, FSD60-2OW AND FSD60-VOW

"OUT OF THE WALL OR FLOOR" THROUGH PENETRATION COMBINATION FIRE/SMOKE DAMPERS
1½ HOUR UL555 RATED, UL555S LEAKAGE RATED

APPLICATION

The FSD60/OW (Leakage Class 1) FSD60-2OW (Leakage Class 2) and FSD60-VOW (Leakage Class 2) combination fire and smoke dampers are designed for vertical (in walls) or horizontal (concrete floors) applications. They can be installed up to 8" (203) outside the fire rated barrier in HVAC systems with airflow in either direction. They have been tested for operation to 2,000 fpm and 4" w.g. on all models and sizes and up to 4,000 fpm and 4" w.g. on select models and sizes (consult Ruskin for model and size information).

STANDARD CONSTRUCTION

FRAME

16 (1.6) gage, galvanized, hat-shaped channel, structurally superior to 13 (2.3) gage channel frame.

BLADES

Airfoil shaped and approximately 6" (152) on center.

SLEEVE

20 (1.0) gage galvanized steel factory installed with thermal insulation on four sides.

SEALS

Blade edge is silicone material for smoke seals to 450°F (232°C) and galvanized steel for flame seal to 1900°F (1038°C). Jamb is stainless steel flexible metal compression type.

LINKAGE

Concealed in frame.

CONTROLLED CLOSURE DEVICE (HEAT-ACTUATED)

165°F (74°C) standard. 212°F (100°C) or 285°F (141°C) are also available at no additional cost.

DAMPER SIZES

MINIMUM SIZES

FSD60OW, FSD60-2OW – 8"w x 6"h (203 x 152).
FSD60-VOW – 6"w x 8"h (152 x 203).

MAXIMUM SIZES

FSD60OW, FSD60-2OW – 32"w x 36"h (813 x 914).
FSD60-VOW – 36"w x 32"h (914 x 813).

OPTIONS

- **FM Approved** as Specification Tested Product.
- **"Out-of-Wall" Grille Access Damper** (See FSD60GA Spec Sheet)
- **TS150 FireStat** for reopenable operation in dynamic smoke management systems.
- **DSD Duct Smoke Detector**.
- **SP100 Switch Package** to remotely indicate damper blade position.
- **Sleeve** of various lengths and gages to insure field compliance with UL installation requirements.
- **Access Door** factory mounted in common sleeve to insure compliance with UL installation requirements.
- **MCP** control panels for test purposes or smoke management systems.

NOTES

1. Dimensions shown in parentheses () indicate millimeters
2. Damper furnished approximately 1/4" (6) smaller than given opening dimensions.

These dampers meet the requirements for fire, smoke and combination fire smoke dampers established by:

- **National Fire Protection Association NFPA Standards** 90A, 92A, 92B and 101
- **BOCA National Building Codes**
- **ICBO Uniform Building Codes**
- **SBCCI Standard Building Codes**
- **ICC International Building Codes**
- **CSFM California State Fire Marshal** (refer to standard spec sheet)
- **New York City** (refer to standard spec sheet)

UL CLASSIFIED

UL555 Listing R5531, UL555S Listing R5531

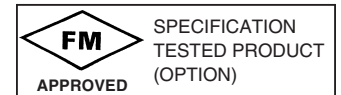

FEATURES

The "Out of the Wall" Through Penetration Fire/Smoke dampers offer:

- EFL (Electric Fuse Link) or PFL (Pneumatic Fuse Link) heat-actuated release devices permit controlled (rather than instantaneous) closure through the damper actuator. The EFL and PFL allow the damper to automatically reopen after a test, smoke detection or power failure conditions.
- EFL is standard on dampers with electric actuators.
- PFL is standard on dampers with pneumatic actuators.
- EFL's may be ordered on dampers with pneumatic actuators but require an additional EP switch (consult factory).

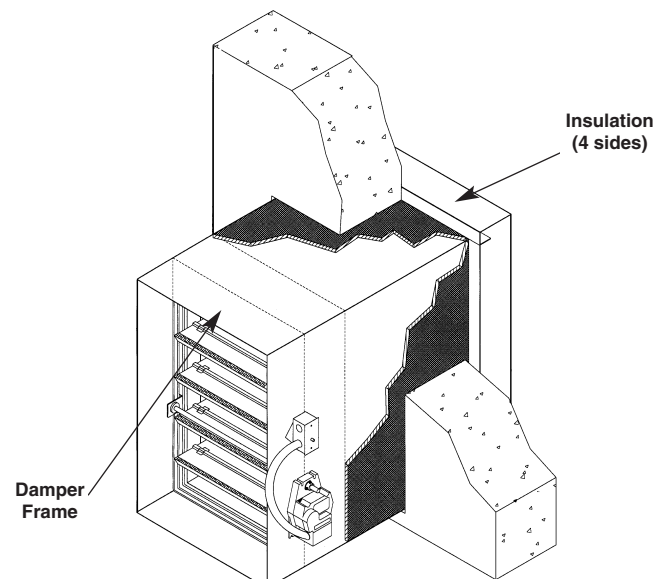

TYPICAL INSTALLATION

Expansion Clearance and Opening Preparation

No expansion clearance is required. The opening in the wall or floor shall be sized to accommodate the overall size of the damper, sleeve and insulation assembly. Size the opening minimum of 1/4" (6) and maximum of 1/2" (13) larger than the nominal damper size for ease of installing the assembly into the opening.

For example a 16"w x 20"h (406 x 508) damper assembly, the opening needs to be sized to 16 1/4"w x 20 1/4"h (413 x 514).

Sleeve Length

Ruskin standard sleeve length is based on a 4" (102) thick wall or floor. Our minimum sleeve lengths are 18" (457) or 21" (533) depending upon the options supplied with the damper.

Longer sleeve lengths are available for wall and floors thicker than 4" (102). The damper can be mounted up to 8" (203) away from the wall or floor but the duct connection can be no further than 16" (406) from the face of the wall or floor on the actuator side and no further than 6" (152) on the non-actuator side.

Consult Ruskin for other applications.

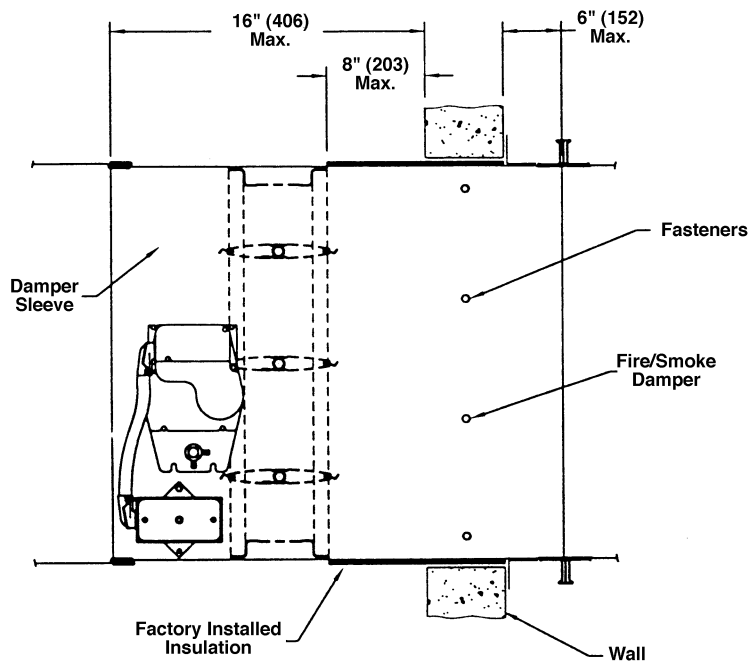

TYPICAL WALL INSTALLATION

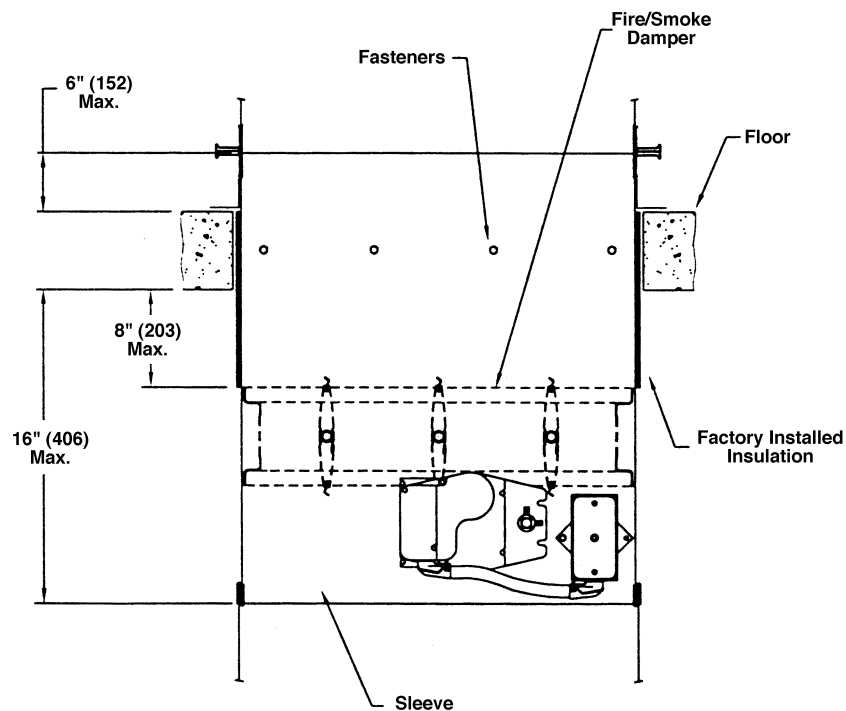

TYPICAL FLOOR INSTALLATION

RUSKIN®

3900 Dr. Greaves Rd.
 Kansas City, MO 64030
 (816) 761-7476
 FAX (816) 765-8955
 www.ruskin.com