

ELF375X and ELF375XH STATIONARY LOUVERS EXTRUDED ALUMINUM

STANDARD CONSTRUCTION

FRAME

4" (102) deep, 6063T5 extruded aluminum. ELF375X - .081" (2.1) nominal wall thickness. ELF375XH - .125" (3.2) nominal wall thickness. Downspouts and caulking surfaces provided.

BLADES

6063T5 extruded aluminum. ELF375X - .081" (2.1) nominal wall thickness. ELF375XH - .125" (3.2) nominal wall thickness. Blades are positioned at 37 1/2° angle and spaced approximately 5 3/32" (129) center to center.

SCREEN

3/4" x .051" (19 x 1.3) expanded, flattened aluminum bird screen in removable frame. Screen adds approximately 1/2" (13) to louver depth.

FINISH

Mill.

MINIMUM SIZE

12"w x 12"h (305 x 305).

APPROXIMATE SHIPPING WEIGHT

ELF375X - 4 lbs./ft.² (19.5 kg/m²).
ELF375XH - 6 lbs./ft.² (29.3 kg/m²).

MAXIMUM FACTORY ASSEMBLY SIZE

Shall be 75 sq. ft. (7m²) per section, not to exceed 120"w x 90"h (3048 x 2286) or 90"w x 120"h (2286 x 3048).

Louvers larger than the maximum factory assembly size will require field assembly of smaller sections.

SUPPORTS

Louvers may be provided with rear mounted blade supports that increase overall louver depth depending on louver size, assembly configuration or windload.

Consult Ruskin for additional information.

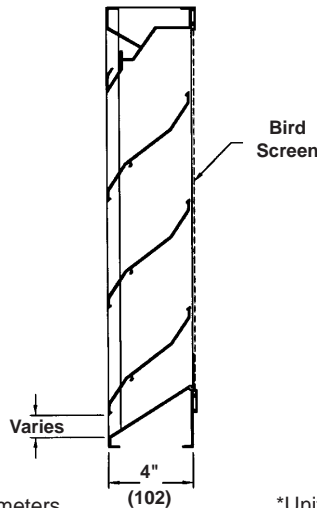
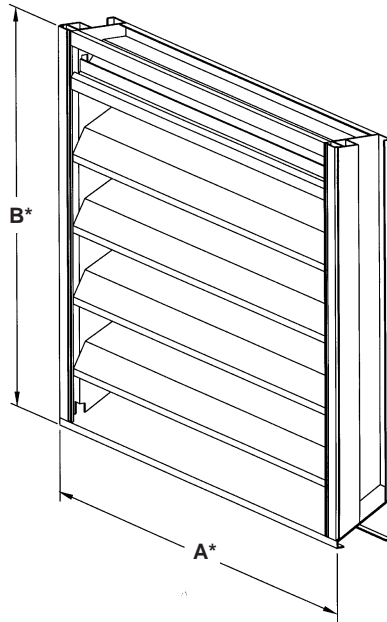

FEATURES

The ELF375X and ELF375XH offers:

- 54% Free Area.
- Published performance ratings based on testing in accordance with AMCA Publication 511.
- High performance frame system with drainable head collects and removes water to provide excellent water penetration performance.
- Architecturally styled, hidden mullions allowing continuous line appearance up to 120" (3048).
- Aluminum construction for low maintenance and high resistance to corrosion.
- All welded construction.

VARIATIONS

Variations to the basic design of these louvers are available at additional cost. They include:

- Extended sill.
- Hinged frame.
- Front or rear security bars.
- Filter racks.
- A variety of bird and insect screens.
- Selection of finishes: prime coat, baked enamel (modified fluoropolymer), epoxy, Acrodize, Kynar, clear and color anodize. (Some variation in anodize color consistency is possible.)

Consult Ruskin for other special requirements.

FRAME CONSTRUCTION

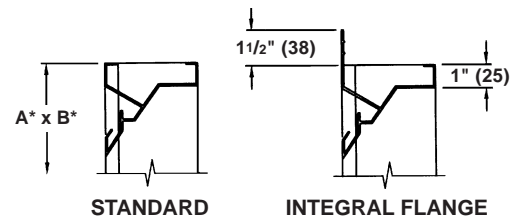

Dimensions in inches, parenthesis () indicate millimeters.

*Units furnished 1/4" (6) smaller than given opening dimensions.

TAG	QTY.	SIZE		FRAME	VARIATIONS
		A*-WIDE	B*-HIGH		
PROJECT ARCH./ENGR. REPRESENTATIVE				LOCATION CONTRACTOR DATE	

SUGGESTED SPECIFICATION

Furnish and install louvers as hereinafter specified where shown on plans or as described in schedules. Louvers shall be stationary type with downspouts in jambs and mullions. Louvers shall have a minimum of 54% free area based on a 48" wide x 48" high (1219 x 1219) size. Stationary blades shall be contained within a 4" (102) frame. Louver components (heads, jambs, sills, blades, & mullions) shall be factory assembled by the louver manufacturer. Louver sizes too large for shipping shall be built up by the contractor from factory assembled louver sections to provide overall sizes required. Louver design shall limit span between visible mullions to 10 feet (3) and shall incorporate structural supports required to withstand a wind load of 20 lbs. per sq. ft. (.96kPa) (equivalent of a 90 mph [145 KPH] wind – specifier may substitute any loading required).

Louvers shall be Ruskin Model ELF375X or ELF375XH extruded 6063T5 aluminum alloy construction as follows:

- Frame: 4" (102) deep, ELF375X - .081" (2.1) wall thickness. ELF375XH - .125" (3.2) wall thickness
- Blades: ELF375X - .081" (2.1) wall thickness. ELF375XH - .125" (3.2) wall thickness at 37¹/₂° angle and spaced approximately 5³/₃₂" (129) center to center.
- Screen: 3/4" x .051 (19 x 1.3) expanded, flattened aluminum in removable frame.
- Finish: Select finish specification from Ruskin Finishes Brochure.

Published louver performance data bearing the AMCA Certified Ratings Seal for Air Performance & Water Penetration must be submitted for approval prior to fabrication and must demonstrate pressure drop and water penetration equal to or less than the Ruskin model specified.

PERFORMANCE DATA

AMCA Standard 500 provides a reasonable basis for testing and rating louvers. Testing to AMCA 500 is performed under a certain set of laboratory conditions. This does not guarantee that other conditions will not occur in the actual environment where louvers must operate.

The louver system should be designed with a reasonable safety factor for louver performance. To ensure protection from water carryover, design with a performance level somewhat below maximum desired pressure drop and .01 oz./sq. ft. of water penetration.

WATER PENETRATION

Test size 48" wide x 48" high (1219 x 1219)

Beginning point of water penetration at .01 oz./sq. ft. is 803 fpm (245 m/min).

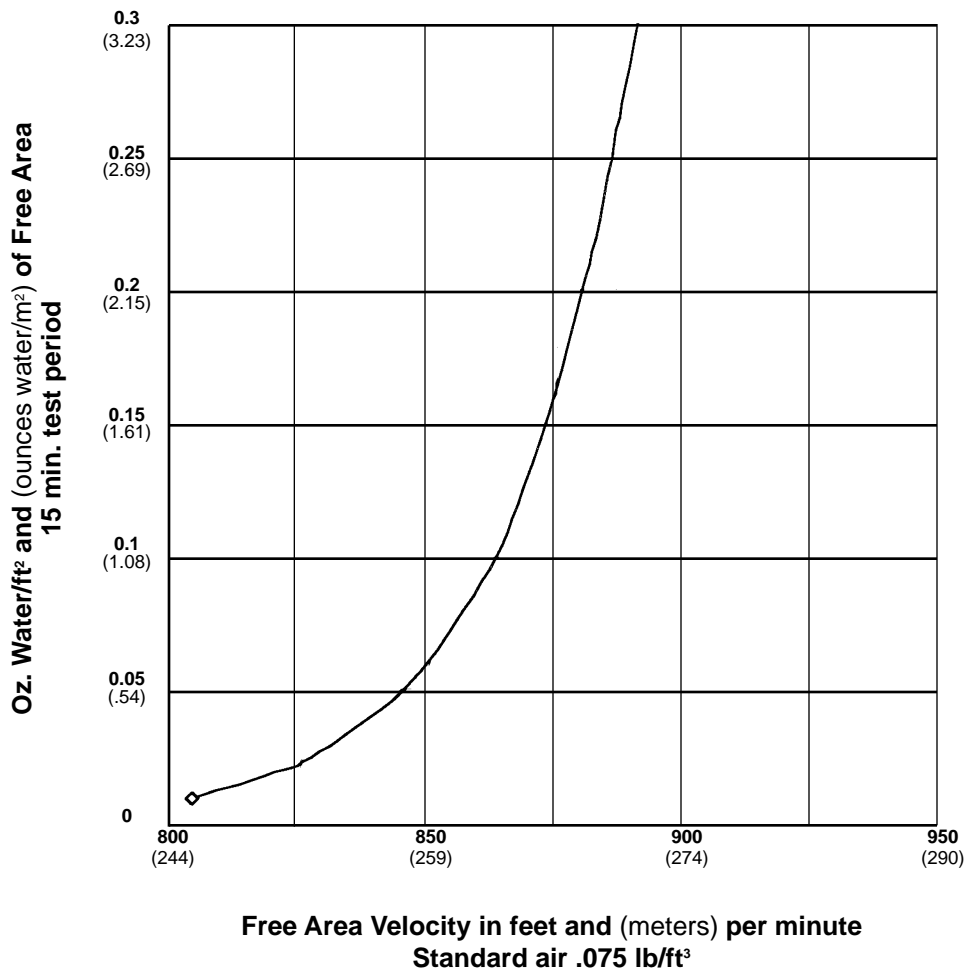

FREE AREA GUIDE

Free Area Guide shows free area in ft² and m² for various sizes of ELF375X and ELF375XH.

	12	18	24	30	36	42	48	54	60	66	72	78	84	90	96	102	108	114	120
	0.30	0.46	0.61	0.76	0.91	1.07	1.22	1.37	1.52	1.68	1.83	1.98	2.13	2.29	2.44	2.59	2.74	2.90	3.05
12	0.26	0.41	0.56	0.71	0.87	1.02	1.17	1.33	1.48	1.63	1.79	1.94	2.09	2.24	2.40	2.55	2.70	2.86	3.01
0.30	0.02	0.04	0.05	0.07	0.08	0.09	0.11	0.12	0.14	0.15	0.17	0.18	0.19	0.21	0.22	0.24	0.25	0.27	0.28
18	0.61	0.97	1.33	1.70	2.06	2.43	2.79	3.15	3.52	3.88	4.25	4.61	4.97	5.34	5.70	6.06	6.43	6.79	7.16
0.46	0.06	0.09	0.12	0.16	0.19	0.23	0.26	0.29	0.33	0.36	0.39	0.43	0.46	0.50	0.53	0.56	0.60	0.63	0.67
24	0.87	1.40	1.92	2.45	2.97	3.50	4.02	4.55	5.07	5.60	6.12	6.65	7.17	7.70	8.22	8.75	9.27	9.80	10.32
0.61	0.08	0.13	0.18	0.23	0.28	0.33	0.37	0.42	0.47	0.52	0.57	0.62	0.67	0.72	0.76	0.81	0.86	0.91	0.96
30	1.14	1.83	2.51	3.20	3.89	4.57	5.26	5.94	6.63	7.33	8.00	8.69	9.37	10.06	10.74	11.43	12.12	12.80	13.49
0.76	0.11	0.17	0.23	0.30	0.36	0.42	0.49	0.55	0.62	0.68	0.74	0.81	0.87	0.93	1.00	1.06	1.13	1.19	1.25
36	1.33	2.13	2.92	3.72	4.52	5.31	6.11	6.91	7.70	8.50	9.30	10.09	10.89	11.69	12.49	13.28	14.08	14.88	15.67
0.91	0.12	0.20	0.27	0.35	0.42	0.49	0.57	0.64	0.72	0.79	0.86	0.94	1.01	1.09	1.16	1.23	1.31	1.38	1.46
42	1.60	2.55	3.51	4.47	5.43	6.39	7.34	8.30	9.26	10.22	11.18	12.13	13.09	14.05	15.01	15.96	16.92	17.88	18.84
1.07	0.15	0.24	0.33	0.42	0.50	0.59	0.68	0.77	0.86	0.95	1.04	1.13	1.22	1.31	1.39	1.48	1.57	1.66	1.75
48	1.86	2.98	4.10	5.22	6.34	7.46	8.58	9.70	10.82	11.93	13.05	14.17	15.29	16.41	17.53	18.65	19.77	20.89	22.00
1.22	0.17	0.28	0.38	0.49	0.59	0.69	0.80	0.90	1.01	1.11	1.21	1.32	1.42	1.52	1.63	1.73	1.84	1.94	2.04
54	2.13	3.41	4.69	5.97	7.25	8.53	9.81	11.09	12.37	13.65	14.93	16.21	17.49	18.77	20.05	21.33	22.61	23.89	25.17
1.37	0.20	0.32	0.44	0.55	0.67	0.79	0.91	1.03	1.15	1.27	1.39	1.51	1.63	1.74	1.86	1.98	2.10	2.22	2.34
60	2.40	3.84	5.28	6.72	8.16	9.61	11.05	12.49	13.93	15.37	16.81	18.25	19.69	21.13	22.57	24.01	25.45	26.90	28.34
1.52	0.22	0.36	0.49	0.62	0.76	0.89	1.03	1.16	1.29	1.43	1.56	1.70	1.83	1.96	2.10	2.23	2.37	2.50	2.63
66	2.59	4.14	5.69	7.24	8.79	10.35	11.90	13.45	15.00	16.55	18.11	19.66	21.21	22.76	24.31	25.86	27.42	28.97	30.52
1.68	0.24	0.38	0.53	0.67	0.82	0.96	1.11	1.25	1.39	1.54	1.68	1.83	1.97	2.12	2.26	2.40	2.55	2.69	2.84
72	2.85	4.57	6.28	7.99	9.71	11.42	13.13	14.84	16.56	18.27	19.98	21.70	23.41	25.12	26.83	28.55	30.26	31.97	33.69
1.83	0.26	0.42	0.58	0.74	0.90	1.06	1.22	1.38	1.54	1.70	1.86	2.02	2.18	2.33	2.49	2.65	2.81	2.97	3.13
78	3.12	5.00	6.87	8.74	10.62	12.49	14.37	16.24	18.11	19.99	21.86	23.74	25.61	27.48	29.36	31.23	33.10	34.98	36.85
1.98	0.29	0.46	0.64	0.81	0.99	1.16	1.34	1.51	1.68	1.86	2.03	2.21	2.38	2.55	2.73	2.90	3.08	3.25	3.42
84	3.39	5.43	7.46	9.50	11.53	13.57	15.60	17.63	19.67	21.70	23.74	25.77	27.81	29.84	31.88	33.91	35.95	37.98	40.02
2.13	0.32	0.50	0.69	0.88	1.07	1.26	1.45	1.64	1.83	2.02	2.21	2.39	2.58	2.77	2.96	3.15	3.34	3.53	3.72
90	3.66	5.86	8.05	10.25	12.44	14.64	16.83	19.03	21.23	23.42	25.62	27.81	30.01	32.20	34.40	36.60	38.79	40.99	43.18
2.29	0.34	0.54	0.75	0.95	1.16	1.36	1.56	1.77	1.97	2.18	2.38	2.58	2.79	2.99	3.20	3.40	3.60	3.81	4.01

Width – Inches and Meters

PRESSURE DROP

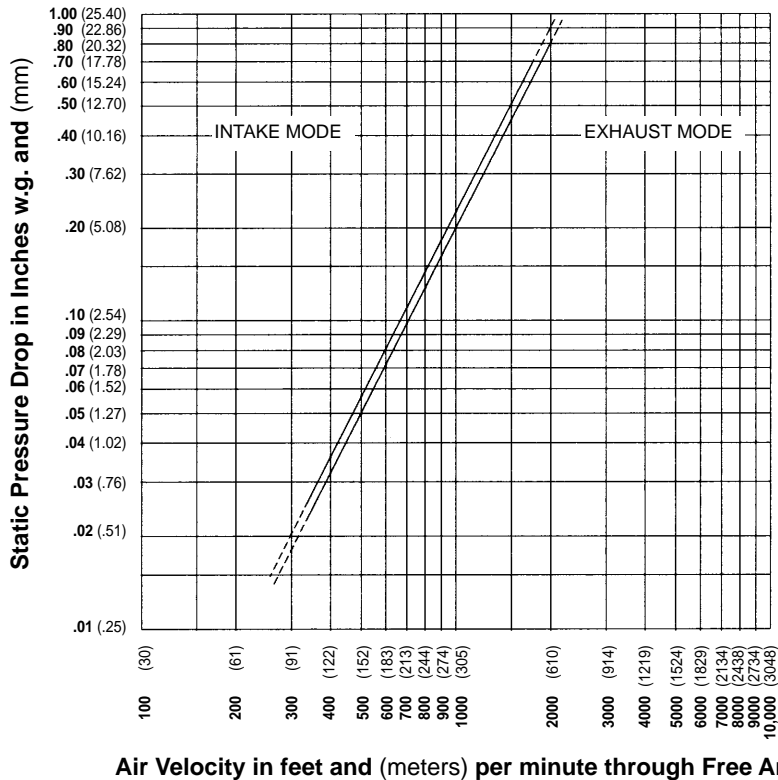

Ratings do not include the effect of a bird screen.



Ruskin Manufacturing Company certifies that the ELF375X and ELF375XH Louvers shown herein are licensed to bear the AMCA Seal. The ratings shown are based on tests and procedures performed in accordance with AMCA Publication 511 and comply with the requirements of the AMCA Certified Ratings Program. The AMCA Certified Ratings Seal applies to air performance ratings and water penetration ratings only.

TYPICAL INSTALLATION DETAILS

Masonry Wall

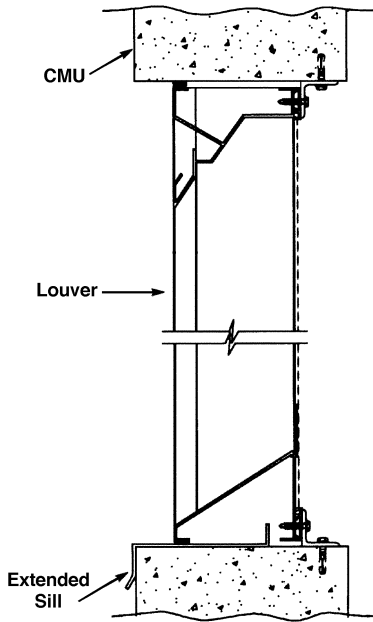

Metal Panel Wall

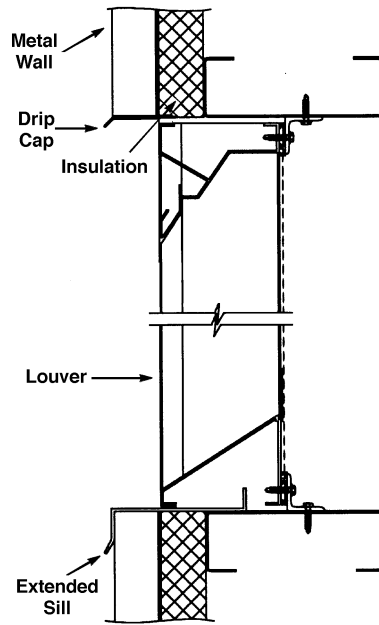

Wood Installation

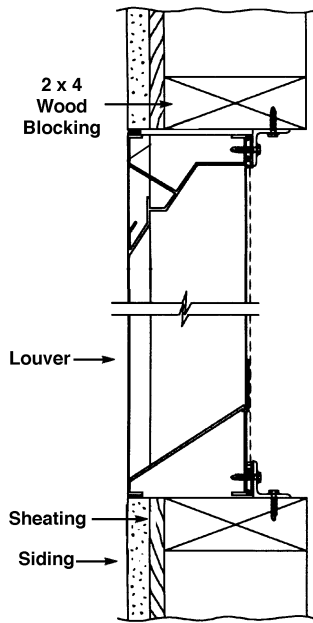

Flange Mount

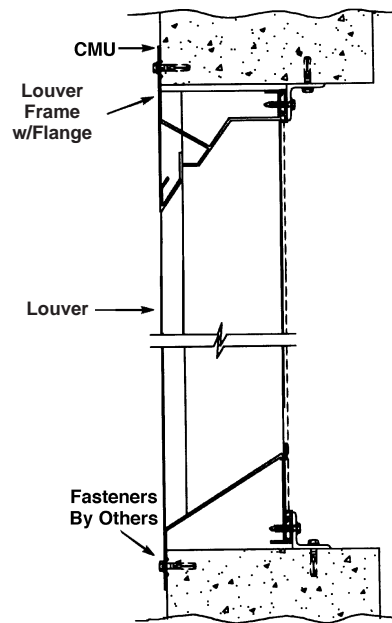

Accessories at additional cost.