

## EV300 VERTICAL SCREEN Extruded Aluminum

### STANDARD CONSTRUCTION

#### BLADES

6063T5 extruded aluminum with .060" (1.5) nominal thickness. Blades are 3" wide and 5/8" deep (76 x 16), spaced at 2" (51) unless otherwise specified. Vertical arrangement is standard.

#### SUPPORT

As required per wind loading. Consult Ruskin.

#### FINISH

Mill is standard. Special finishes such as Kynar, Acrodize, baked enamel (modified fluoropolymer), epoxy, prime coat, integral color and clear anodize are available at additional cost. (Some variation in anodize color consistency is possible).

#### MINIMUM SIZE

12" w X 12" h (305 X 305).

#### APPROXIMATE SHIPPING WEIGHT

4 lbs. per sq. ft.

#### MAXIMUM FACTORY ASSEMBLY SIZE

Shall be 64 sq. ft. (6m<sup>2</sup>) per section, not to exceed 240" wide and 90" high (6096 and 2286) or 90" wide and 240" high (2286 and 6096).

Screens larger than maximum factory assembly size will require field assembly of smaller sections.

### FEATURES

The EV300 design offers:

- Low profile rear supports for attractive appearance.
- Excellent visual screening with airflow.
- Horizontal blade arrangement option.

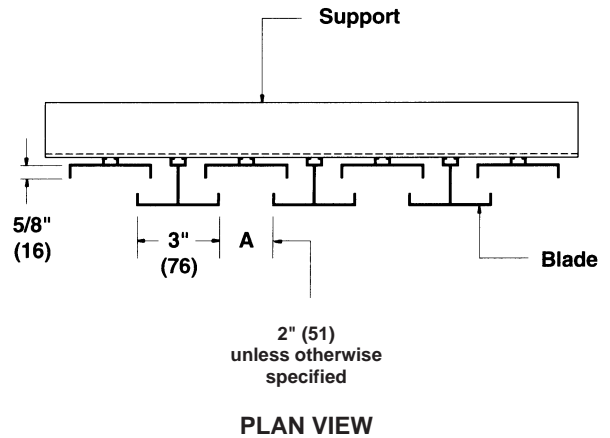

### NOTES

1. Maximum blade support spacing is 48" (1219) center to center.
2. Additional structural framing must be provided by others as required by job specifications and conditions.
3. All options are at additional cost.

### SUGGESTED SPECIFICATION

Furnish and install vertical screens as hereinafter specified where shown on plans or as described in schedules. Screen components shall be factory assembled by the manufacturer. Sizes too large for shipping shall be built up by the contractor from factory assembled sections to provide overall sizes required. Design shall incorporate structural supports required to withstand a wind load of 20 lbs. per sq. ft. (96 kPa, equivalent of a 90 mph wind [145 KPH] – specifier may substitute any loading required).

Screens shall be Ruskin Model EV300 6063T5 extruded aluminum alloy construction as follows:

- Blades: .060" (1.5) wall thickness, 3" wide x 5/8" deep (76 x 16), spaced at 2" (51) unless otherwise specified.
- Fasteners: Anchorage shall be concealed and not visible on the exterior face of the screen.
- Finish: Select finish specification from Ruskin/Valspar Finishes Brochure.

Dimensions in parenthesis ( ) indicate millimeters.

Units are furnished actual size.

| QTY.  | SIZE |      | A-BLADE SPACING                         | VARIATIONS |
|---|------|------|---|------------|
|   | WIDE | HIGH |   |            |
|   |      |      |   |            |
|   |      |      |   |            |
|   |      |      |   |            |
|   |      |      |   |            |
|   |      |      |   |            |
|   |      |      |   |            |
|   |      |      |   |            |
|   |      |      |   |            |
| <b>PROJECT<br/>ARCH./ENGR.<br/>REPRESENTATIVE</b> |      |      | <b>LOCATION<br/>CONTRACTOR<br/>DATE</b> |            |

# TYPICAL INSTALLATION DETAIL

---

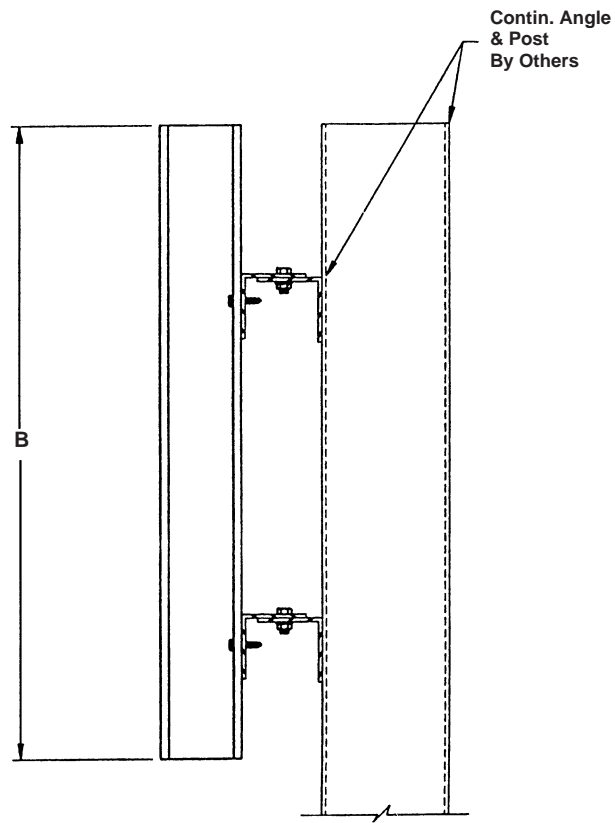

**RUSKIN**<sup>®</sup>

3900 Dr. Greaves Rd.  
Kansas City, MO 64030  
(816) 761-7476  
FAX (816) 765-8955