

DFD60-3 MULTIPLE BLADE DYNAMIC FIRE DAMPER 3 HOUR RATING UL555 RATED FOR USE IN "DYNAMIC" OR "STATIC" SYSTEMS

APPLICATION

The DFD60-3 is a 3 hour rated multiple blade Dynamic (Fan On) fire damper. It is constructed with airfoil blades for high velocity applications and is rated for 2,000 fpm and 4" w.g. on all sizes and 4,000 fpm and 8" w.g. on select sizes. The DFD60-3 is also rated for dual direction air flow and can be installed vertically in walls or horizontally in masonry floors.

STANDARD CONSTRUCTION

FRAME

5" x 1" x 16 gage (127 x 25 x 1.52) galvanized, steel hat channel, structurally superior to 13 gage (2.3) channel frame.

BLADES

Single piece, airfoil-shaped construction with 14 gage (1.90) equivalent, approximately 6" (152) on center.

BEARINGS

Stainless steel sleeve, pressed into frame.

LINKAGE

Concealed in frame.

AXLES

1/2" (13) plated steel hex.

FUSIBLE LINK

165°F (74°C) standard. 212°F (100°C) available.

DAMPER WEIGHT

Approximately 8 lbs. per sq. ft. without damper sleeve.

DAMPER SIZES

MINIMUM SIZE

Vertical or Horizontal Installation – 8"w x 6"h (203 x 152)

MAXIMUM SIZES

Single Section

Vertical or Horizontal Installation – 30"w x 48"h (762 x 1219)

Multiple Section – 2000 fpm and 4" w.g.

Vertical or Horizontal Installation – 120"w x 48"h (3048 x 1219) or 72"w x 96"h (1829 x 2438)

Multiple Section – 3000 fpm and 6" w.g.

Vertical Installation – 90"w x 64"h (2286 x 1626) or 120"w x 32"h (3048 x 813) or 60"w x 96"h (1524 x 2438)

Horizontal Installation – 60"w x 48"h (1524 x 1219) or 30"w x 96"h (762 x 2438)

Multiple Section – 4000 fpm and 8" w.g.

Vertical or Horizontal Installation – 60"w x 48"h (1524 x 1219) or 30"w x 96"h (762 x 2438)

OPTIONS

- **FM Approvals** as Specification Tested Product.
- **SP100 Switch Package** to remotely indicate damper blade position.
- **PFMA Angles** for two side angle installation.
- **Sleeve** of various lengths and gages to insure field compliance with UL installation requirements.
- **Jamb Seals** stainless steel flexible metal compression type.
- **Blade Seals** silicone blade edge seal.

NOTES

1. Dimensions in inches, parentheses () indicate millimeters.
2. Damper/sleeve assembly furnished actual size.

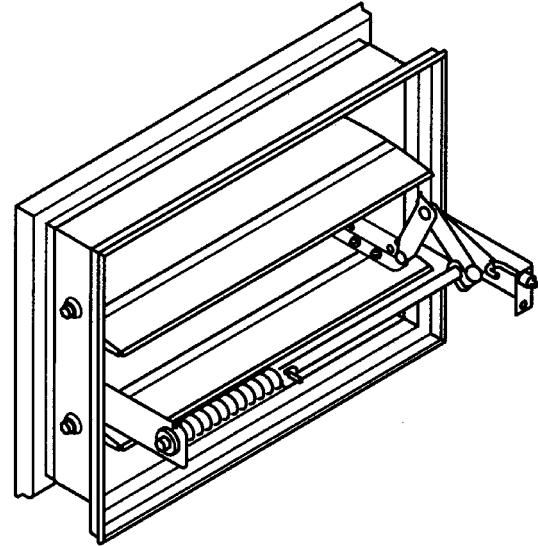

The DFD60-3 damper meets the requirements for fire dampers established by:

- **National Fire Protection Association NFPA Standards** 90A, 92A, 92B and 101
- **ICC International Building Codes**
- **CSFM California State Fire Marshal Listing** #3225-245:102

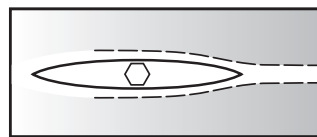

Ruskin Airfoil Blade



AMCA LICENSED AIR PERFORMANCE DATA



Ruskin Company certifies that the DFD60-3 shown hereon is licensed to bear the AMCA Seal. The ratings shown are based on tests and procedures performed in accordance with AMCA Publication 511 and comply with the requirements of the AMCA Certified Ratings Program. The AMCA Certified Ratings Seal applies to air performance for the DFD60-3.

To determine the AMCA Licensed air performance:

Locate the applicable feet per minute face velocity on the bottom of the velocity vs. pressure drop chart below. Move up the chart to the most appropriate size damper line. From the intersection point, move left to determine the pressure drop on the left side of the chart.

VELOCITY vs. PRESSURE DROP

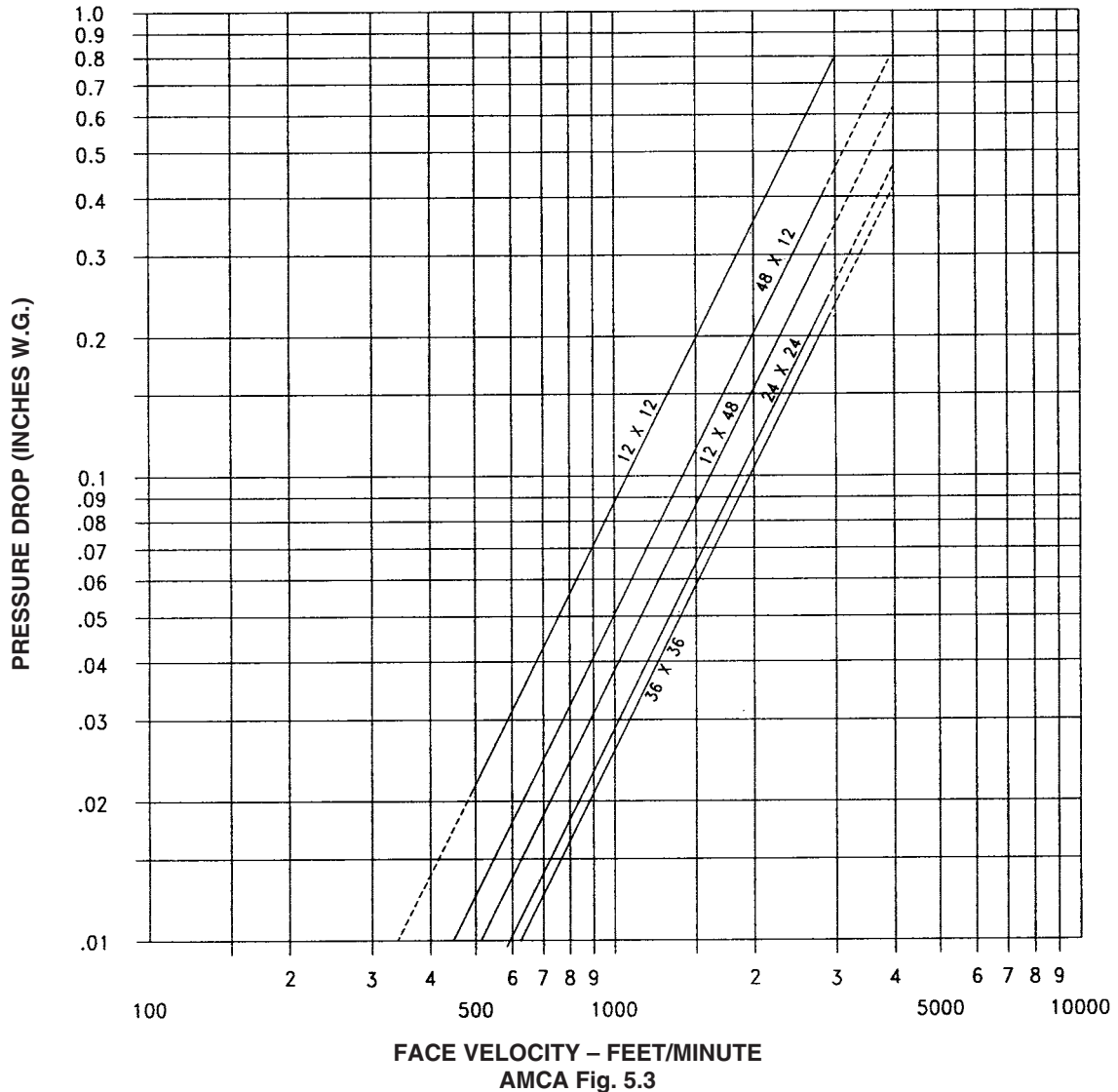

DAMPER DIMENSIONAL DATA

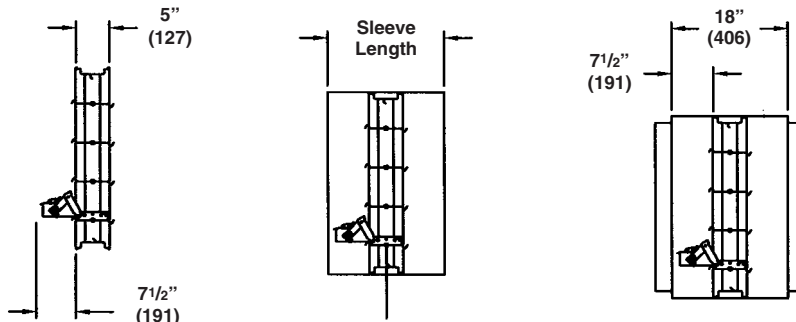

Sleeve Dimensions

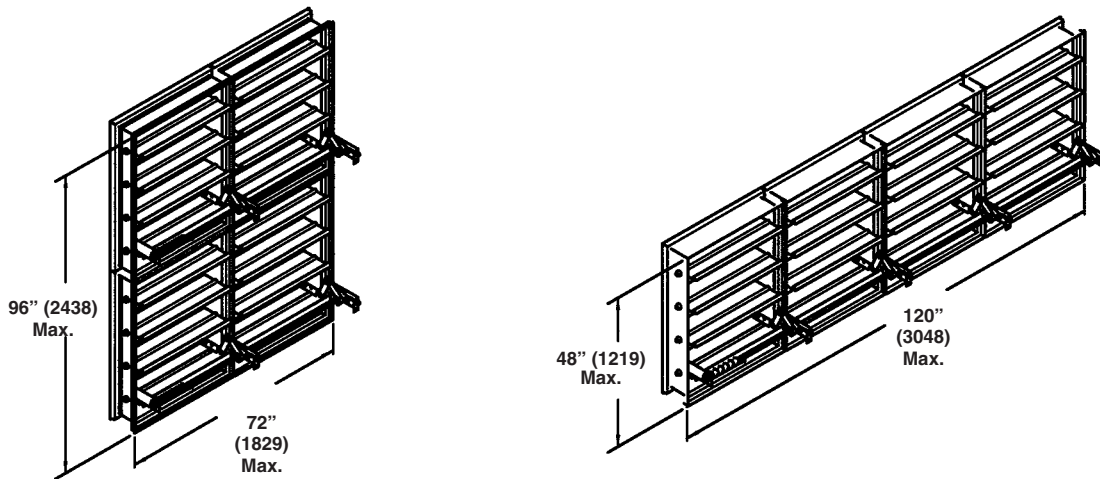

DFD60-3 Multiple Sections

FUSE LINK ADJUSTMENT

To Test or Replace the Fuse Link

1. Loosen the nuts on the J-bolt (Do not remove the nuts all together).
2. Remove the truarc ring.
3. Turn the jackshaft to open the damper and remove the fuse link.
4. Cycle the damper full open to full close positions, making sure the damper operates freely.

The damper should be able to spring closed in any position.

5. Replace the fuse link and adjust the damper into the original position.

Note: The damper can be adjusted in any position for volume control operation.

CAUTION

Damper assembly is under spring tension. Care should be taken to avoid bodily injury or damage to the damper assembly.

ITEM	DESCRIPTION
1.	Multiple Blade Fire Damper
2.	Fusible Link Issue 'E'
3.	Fuse Link Linkage
4.	J-Bolt
5.	Truarc Ring 1/4" (6)
6.	Over Center Linkage
7.	Jackshaft Assembly

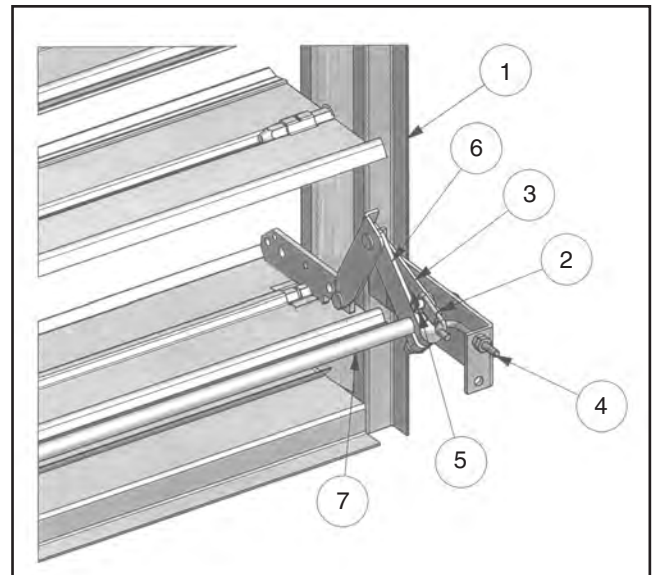

SLEEVE TRANSITION DIMENSIONAL INFORMATION

DUCT TRANSITION CONNECTIONS

DFD60-3 dampers may be supplied with Round, Oval and Rectangular duct connections.

Style	Description
B	Units Under 6" (152) Tall
R	Round Non-Sealed (Low Pressure)
CR	Round Sealed (Medium Pressure)
WR	Round Welded (High Pressure)
C	Rectangular Sealed (Low and Medium Pressure)
WC	Rectangular Welded (High Pressure)
LO	Oval Non-Sealed (Low Pressure)
CO	Oval Sealed (Medium Pressure)
WO	Oval Welded (High Pressure)

The square damper size will be 2" (51) larger in width and height than the round, oval or rectangular duct size ordered.

MINIMUM and MAXIMUM SIZES

Round Transitions

Minimum 6" (152) diameter
Maximum DFD60-3 – 58" (1473) diameter

Rectangular and Oval Transitions

Minimum 6" w x 4" h (152 x 102) diameter
Maximum DFD60-3 – 118" w x 46" (2997 x 1168)

'B' Style Transitions

Minimum height 4" (102) 'B' style transitions are utilized on units where the damper height is less than 6" (152).

Consult Ruskin for other available styles and sizes.

Note: For medium pressure units (Styles CR, C and CO) the collar extends 1 1/2" (38) beyond the sleeve length and for low pressure and high pressure units (Styles R, WR, WC and LO) the collar extends 2 1/2" (64) beyond the sleeve length.

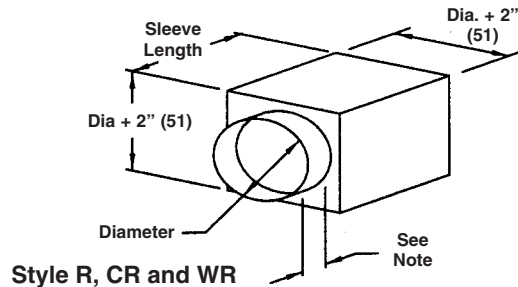
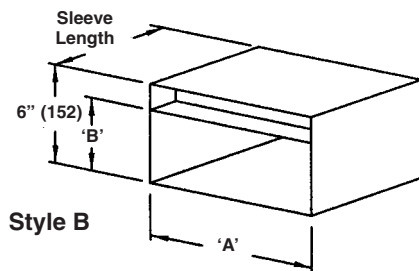
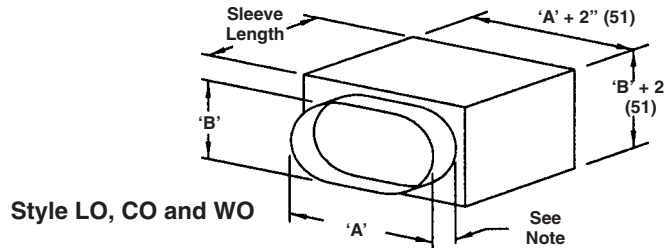
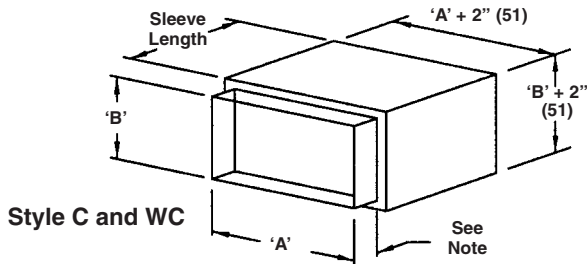

SUGGESTED SPECIFICATION

Furnish and install at locations shown on plans or as described in schedules AMCA Certified fire dampers constructed and tested in accordance with UL Safety Standard 555 that meet or exceed the following specifications. Fire Dampers shall be produced in an ISO 9001 certified factory.

Damper frame, where size permits, shall be constructed using Uniframe Design Concept (UDC) and shall be minimum 16 gage (1.52) galvanized steel formed into a structural hat channel superior to 13 gage (2.30) channel frame. Top and bottom frame members on dampers less than 13" (330) high shall be low profile design to maximize the free area of these smaller dampers. Damper blades shall be single piece airfoil shaped with 14 gage (1.90) equivalent thickness. Airfoil type blades generate low pressure drop and low noise levels. Bearings shall be stainless steel, permanently lubricated sleeve type turning in an extruded hole in the frame for maximum life.

Each fire damper shall have a 3 hour fire protection rating and shall be supplied with a 165°F (74°C) or 212°F (100°C) fusible link. Fire

dampers shall be approved for vertical or horizontal mounting as required by the location shown and shall be installed using steel sleeves, angles and other materials and practice required to provide an installation in accordance with the damper manufacturer's installation instructions. Submittal information shall include the fire protection, maximum velocity and pressure ratings and the manufacturer's UL installation instructions. In addition, the fire dampers shall be AMCA licensed for air performance.

Each fire damper shall be labeled for use in dynamic systems. Static only dampers labels are not permissible. The damper shall be rated for dynamic closure at 2000 fpm (10.2 m/s) and 4" w.g. (1 kPa) static pressure and shall be tested and rated to close with airflow in either direction. Vertical and Horizontal dampers installed in walls and floors shall have extended dynamic closure and operational ratings of 4000 fpm (20.3 m/s) and 8" w.g. (2 kPa).

Dynamic fire dampers shall be Ruskin model DFD60-3.

(Consult www.ruskin.com for electronic version of this "Quick" spec as well as for complete 3-part CSI MasterFormat Specifications)

RUSKIN®

3900 Dr. Greaves Rd.
Kansas City, MO 64030
(816) 761-7476
FAX (816) 765-8955
www.ruskin.com

Printed on recycled paper
using vegetable based inks

