

S-SERIES ENERGY RECOVERY VENTILATOR OUTDOOR SIDE BY SIDE DISCHARGE

STANDARD CONSTRUCTION

CABINET

20 (1.0) gage galvanized steel.

PANELS

18 (1.3) gage galvanized steel.

FINISH

Polyester Resin based powder coat.
Off White color.

WHEEL

ARI rated Internal Enthalpy Wheel.

FILTERS

Intake: Aluminum Mist Eliminator
Exhaust: 2" Pleated

TEMPERATURE LIMITS

+10°F (-12°C) to. +115°F (+46°C).

OPTIONS

- Roof Curb
- Low Ambient Kit (LAK)
- Motorized Outside Air Damper (MOAD)
- Motorized Exhaust Air Damper (MEAD)
- Start-Stop-Jog (SSJ)
- Disconnect for Field Installation (Disc)
- Rotation Sensor (RS)
- Pressure Sensor (PS)
- Dirty Filter Switch (DFS)
- Variable Frequency Drives (VFD)

Dimensions shown in parentheses () indicate millimeters.

FEATURES

"S" series energy recovery ventilators are designed for outside use in rooftop or "pad" installations where the application required a side-by-side duct system. One of the benefits of this design is the ability to easily be connected to the horizontal ductwork of an air conditioning system. Balancing dampers should be utilized to help control the air volumes.

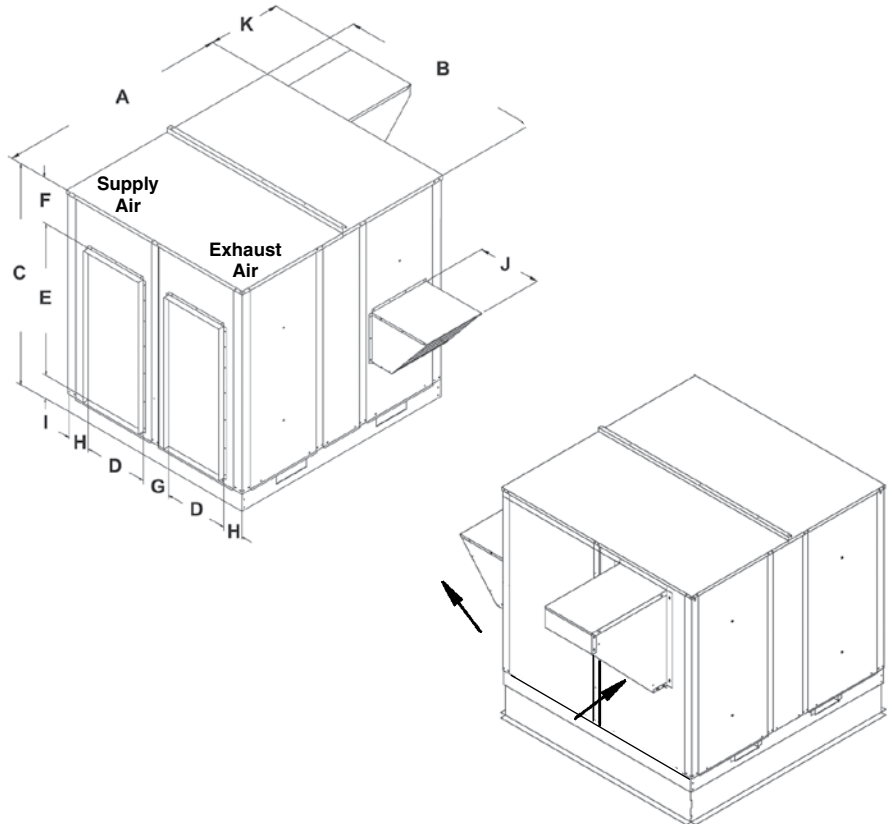

ERV Model	CFM Range	Dimensions (in inches)										
		A	B	C	D	E	F	G	H	I	J	K
S11-02	300-1100	44.75	32.13	33.50	11.00	27.00	4.00	4.25	2.88	2.50	20.75	14.38
S20-02	1200-2000	54.38	37.25	37.50	12.00	30.00	5.87	5.13	4.06	1.63	20.75	17.50
S28-02	1200-2800	52.25	42.63	43.56	14.00	32.00	8.69	5.25	4.25	2.88	20.75	25.50
S36-02	2000-3600	60.00	46.69	57.37	16.50	39.50	12.00	5.50	4.05	5.88	20.75	25.50
S46-02	3000-4600	60.00	52.69	57.37	16.50	39.50	12.00	8.69	5.50	5.88	20.75	28.06
S62-02	4600-6200	72.00	70.88	63.63	19.50	39.50	17.53	14.50	8.70	6.60	20.75	37.75

Qty.	Model	Motor Data			Options											TAG	
		Voltage	Phase	Cycle	Curb		LAK	MEAD	MOAD	SSJ	Disc.	RS	PS	DFS	VFD		
					14"	24"											

SPECIFICATIONS AND ELECTRICAL DATA								
Model Numbers		S11-02 Stand Alone S/S 300 - 1100 CFM ERV				S20-02 Stand Alone S/S 1200 - 2000 CFM ERV		
Line Voltage – 60hz		208/230v 1ph	208/230v 3ph	460v 3ph	575v 3ph	208/230v 3ph	460v 3ph	575v 3ph
Fresh Air Blower	Motor – hp	1.5 / Belt				2 / Belt		
	Wheel Size (dia x width) – in	9 x 4				9 x 9		
	Motor Speed – rpm	1725				1725		
	Motor Speed(s)	Adjustable Sheave				Adjustable Sheave		
	Bearing Type	Ball				Ball		
	Full Load Amps	9.1	5.6	2.8	2.0	6.0	2.6	2.4
	Service Factor	1.15				1.15		
Exhaust Air Blower	Motor – hp Stationary	1.5 / Belt				2 / Belt		
	Wheel Size (dia x width) – in	9 x 4				9 x 9		
	Motor Speed – rpm	1725				1725		
	Motor Speed(s)	Adjustable Sheave				Adjustable Sheave		
	Bearing Type	Ball				Ball		
	Full Load Amps	9.1	5.6	2.8	2.0	6.0	2.6	2.4
	Service Factor	1.15				1.15		
Wheel Electrical Data	Potential Volts	208 - 230				208 - 230		
	Motor Speed – rpm	1050				1050		
	Full Load Amps	0.3				0.3		
Total Electrical	MCA – Stationary	20.8	12.9	6.6	4.8	13.8	6.2	5.7
	OCPD – Stationary	30	15	9	7	20	9	8
Wheel Data	Wheel Depth – in	3				3		
	Wheel Diameter – in	25.3				30.346		
	Construction / Media Type	One Piece / Polymeric				One Piece / Polymeric		
Curb	Curb Height – in	14				14		
Weights	Shipping Weight – lbs. (kg)	389				650		
	Net Weight – lbs. (kg)	314				570		

S11 ARI CERTIFIED RATINGS					
Thermal Ratings @ 0" Pressure Diff.			Sensible	Latent	Total
Total Effectiveness	100% Airflow Heating		76%	68%	73%
	75% Airflow Heating		81%	73%	78%
	100% Airflow Cooling		76%	68%	72%
	75% Airflow Cooling		81%	73%	76%
Net Effectiveness	100% Airflow Heating		76%	68%	73%
	75% Airflow Heating		81%	73%	78%
	100% Airflow Cooling		76%	68%	72%
	75% Airflow Cooling		81%	73%	76%
Enthalpy Wheel ARI Rating Data					
Nominal Airflow CFM	900 @ 1.0Δ	Nominal Airflow CFM	900 @ 1.0Δ		
EATR – -1.00 H ₂ O	9.30%	OACF – -1.00 H ₂ O	0.97		
EATR – 0.00 H ₂ O	0.70%	OACF – 0.00 H ₂ O	1.19		
EATR – +1.00 H ₂ O	0.00%	OACF – +1.00 H ₂ O	1.34		

S20 ARI CERTIFIED RATINGS					
Thermal Ratings @ 0" Pressure Diff.			Sensible	Latent	Total
Total Effectiveness	100% Airflow Heating		68	61	65
	75% Airflow Heating		72	67	71
	100% Airflow Cooling		68	61	64
	75% Airflow Cooling		72	67	70
Net Effectiveness	100% Airflow Heating		68	61	65
	75% Airflow Heating		72	67	71
	100% Airflow Cooling		68	61	64
	75% Airflow Cooling		72	67	70
Enthalpy Wheel ARI Rating Data					
Nominal Airflow CFM	1600 @ .95Δ	Nominal Airflow CFM	1600 @ .95Δ		
EATR – -1.00 H ₂ O	7.80%	OACF – -1.00 H ₂ O	0.97		
EATR – 0.00 H ₂ O	0.40%	OACF – 0.00 H ₂ O	1.16		
EATR – +1.00 H ₂ O	0.00%	OACF – +1.00 H ₂ O	1.29		

SPECIFICATIONS AND ELECTRICAL DATA

Model Numbers		S28-02 – Stand Alone S/S 1200 - 2800 CFM ERV			S36-02 – Stand Alone S/S 2000 - 3600 CFM ERV		
		208/230v 3ph	460v 3ph	575v 3ph	208/230v 3ph	460v 3ph	575v 3ph
Line Voltage – 60hz							
Fresh Air Blower	Motor – hp / type	3 / Belt			3 / Belt		
	Wheel Size (dia x width) – in	10 x 10			12 x 9		
	Motor Speed – rpm	1725			1725		
	Motor Speed(s)	Adjustable Sheave			Adjustable Sheave		
	Bearing Type	Ball			Ball		
	Full Load Amps	9.4	4.3	3.2	9.4	4.3	3.2
	Service Factor	1.15			1.15		
Exhaust Air Blower	Motor – hp Stationary	3 / Belt			3 / Belt		
	Wheel Size (dia x width) – in	10 x 10			12 x 9		
	Motor Speed – rpm	1725			1725		
	Motor Speed(s)	Adjustable Sheave			Adjustable Sheave		
	Bearing Type	Ball			Ball		
	Full Load Amps	9.4	4.3	3.2	9.4	4.3	3.2
	Service Factor	1.15			1.15		
Enthalpy Wheel Electrical Data	Motor – hp (1 phase)	0.005			0.17		
	Potential Volts	200 / 208 - 230			200 / 208 - 230		
	Motor Speed – rpm	825			1075		
	Full Load Amps	0.6			1.2		
Total Electrical	MCA – Stationary	21.8	10.3	7.8	22.4	10.9	8.4
	OCPD – Stationary	30	12	10	30	15	10
Wheel Data	Wheel Depth x Diameter – in	3 x 37.759			3 x 41.825		
	Construction / Media Type	Segmented Pies / Polymeric			Segmented Pies / Polymeric		
Curb	Curb Height – in	14			14		
Weights	Shipping Weight – lbs. (kg)	876			950		
	Net Weight – lbs. (kg)	801			854		

S28 ARI CERTIFIED RATINGS

Thermal Ratings @ 0" Pressure Diff.		Sensible	Latent	Total
Total Effectiveness	100% Airflow Heating	68%	60%	65%
	75% Airflow Heating	74%	67%	71%
	100% Airflow Cooling	68%	60%	63%
	75% Airflow Cooling	74%	67%	70%
Net Effectiveness	100% Airflow Heating	68%	60%	65%
	75% Airflow Heating	74%	67%	71%
	100% Airflow Cooling	68%	60%	63%
	75% Airflow Cooling	74%	67%	70%

Enthalpy Wheel ARI Rating Data

Nominal Airflow CFM	2600 @ .95Δ	Nominal Airflow CFM	2600 @ .95Δ
EATR – -1.00 H ₂ O	6.10%	OACF – -1.00 H ₂ O	0.99
EATR – 0.00 H ₂ O	0.40%	OACF – 0.00 H ₂ O	1.13
EATR – +1.00 H ₂ O	0.00%	OACF – +1.00 H ₂ O	1.23

S36 ARI CERTIFIED RATINGS

Thermal Ratings @ 0" Pressure Diff.		Sensible	Latent	Total
Total Effectiveness	100% Airflow Heating	68	60	65
	75% Airflow Heating	74	67	71
	100% Airflow Cooling	68	60	63
	75% Airflow Cooling	74	67	70
Net Effectiveness	100% Airflow Heating	68	60	65
	75% Airflow Heating	74	67	71
	100% Airflow Cooling	68	60	63
	75% Airflow Cooling	74	67	70

Enthalpy Wheel ARI Rating Data

Nominal Airflow CFM	3100 @ .9Δ	Nominal Airflow CFM	3100 @ .9Δ
EATR – -1.00 H ₂ O	4.90%	OACF – -1.00 H ₂ O	0.99
EATR – 0.00 H ₂ O	1.30%	OACF – 0.00 H ₂ O	1.07
EATR – +1.00 H ₂ O	0.30%	OACF – +1.00 H ₂ O	1.12

SPECIFICATIONS AND ELECTRICAL DATA							
Model Numbers		S46-02 – Stand Alone S/S 3000 - 4600 CFM ERV			S62-02 – Stand Alone S/S 4600 - 6200 CFM ERV		
Line Voltage – 60hz		208/230v 3ph	460v 3ph	575v 3ph	208/230v 3ph	460v 3ph	575v 3ph
Fresh Air Blower	Motor – hp / type	5 / Belt			5 / belt		
	Wheel Size (dia x width) – in	12 x 12			15 x 15		
	Motor Speed – rpm	1725			1725		
	Motor Speed(s)	Adjustable Sheave			Adjustable Sheave		
	Bearing Type	Ball			Ball		
	Full Load Amps	14.0	7.0	5.1	14.0	7.0	5.1
	Service Factor	1.15			1.15		
Exhaust Air Blower	Motor – hp Stationary	5 / Belt			5 / belt		
	Wheel Size (dia x width) – in	12 x 12			15 x 15		
	Motor Speed – rpm	1725			1725		
	Motor Speed(s)	Adjustable Sheave			Adjustable Sheave		
	Bearing Type	Ball			Ball		
	Full Load Amps	14.0	7.0	5.1	14.0	7.0	5.1
	Service Factor	1.15			1.15		
Enthalpy Wheel Electrical Data	Motor – hp (1 phase)	0.17			.17		
	Potential Volts	200 / 208 - 230			200 / 208 – 230		
	Motor Speed – rpm	1075			1075		
	Full Load Amps	1.2			1.2		
Total Electrical	MCA – Stationary	32.7	17.0	12.7	32.7	17.0	12.7
	OCPD – Stationary	40	25	15	40	25	15
Wheel Data	Wheel Depth x Diameter – in	3 x 46.776			3 x 52.026		
	Construction / Media Type	Segmented Pies / Polymeric			Segmented Pies / Polymeric		
Curb	Curb Height – in	14			14		
Weights	Shipping Weight – lbs. (kg)	1228			1380		
	Net Weight – lbs. (kg)	1113			1205		

S46 ARI CERTIFIED RATINGS					
Thermal Ratings @ 0" Pressure Diff.			Sensible	Latent	Total
Total Effectiveness	100% Airflow Heating		68%	60%	65%
	75% Airflow Heating		73%	67%	71%
	100% Airflow Cooling		68%	60%	63%
	75% Airflow Cooling		73%	67%	70%
Net Effectiveness	100% Airflow Heating		68%	60%	65%
	75% Airflow Heating		73%	67%	71%
	100% Airflow Cooling		68%	60%	63%
	75% Airflow Cooling		73%	67%	70%
Enthalpy Wheel ARI Rating Data					
Nominal Airflow CFM	3900 @ .9Δ	Nominal Airflow CFM	3900 @ .9Δ		
EATR – -1.00 H ₂ O	4.40%	OACF – -1.00 H ₂ O	0.99		
EATR – 0.00 H ₂ O	1.10%	OACF – 0.00 H ₂ O	1.06		
EATR – +1.00 H ₂ O	0.20%	OACF – +1.00 H ₂ O	1.11		

S62 ARI CERTIFIED RATINGS					
Thermal Ratings @ 0" Pressure Diff.			Sensible	Latent	Total
Total Effectiveness	100% Airflow Heating		68	60	65
	75% Airflow Heating		73	67	71
	100% Airflow Cooling		68	60	63
	75% Airflow Cooling		73	67	70
Net Effectiveness	100% Airflow Heating		68	60	65
	75% Airflow Heating		73	67	71
	100% Airflow Cooling		68	60	63
	75% Airflow Cooling		73	67	70
Enthalpy Wheel ARI Rating Data					
Nominal Airflow CFM	5500 @ .95Δ	Nominal Airflow CFM	5500 @ .95Δ		
EATR – -1.00 H ₂ O	4.00%	OACF – -1.00 H ₂ O	0.99		
EATR – 0.00 H ₂ O	1.00%	OACF – 0.00 H ₂ O	1.06		
EATR – +1.00 H ₂ O	0.20%	OACF – +1.00 H ₂ O	1.12		

FILTER SIZES

Series	Size	Return Filter				Intake Filter			
		Qty	Width	Height	Type	Qty	Width	Height	Type
S	11	1	14	20	2" PLT	1	16.25	10.375	1" ME
	20	2	16	20		1	12.5	20	
	28	2	20	20		1	14.75	32.25	
	36	3	16	20		1	16.5	32.25	
	46	2	24	24		1	20	36	
	62	5	14	20		1 / 1	20 / 20	36 / 12.5	

SERVICE CLEARANCES

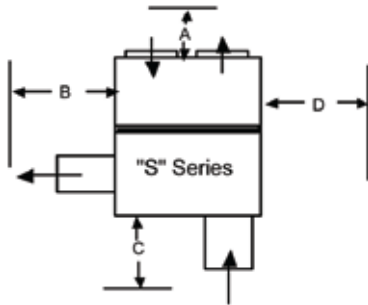

Dimension (inches)	"S" SERIES					
	11	20	28	36	46	62
A	12	12	12	12	12	12
B	60	60	60	60	60	60
C	48	60	60	60	72	72
D	36	36	48	48	60	60

OPTIONAL CURB DETAIL

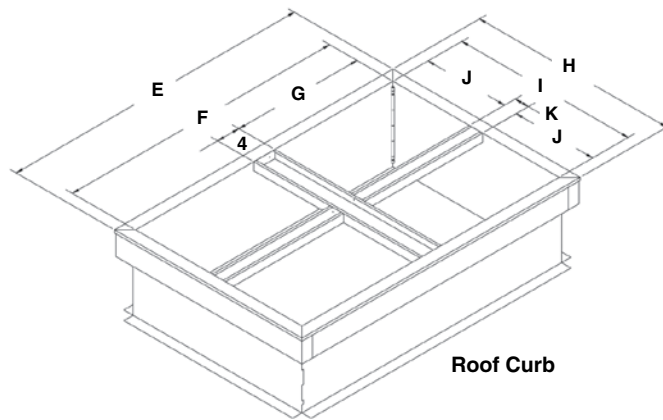

ERV Model	Dimensions (in inches)						
	E	F	G	H	I	J	K
S11-02	43.00	39.00	17.50	30.25	26.25	11.88	2.50
S20-02	52.75	48.75	22.38	35.50	31.50	14.50	2.50
S28-02	49.50	45.50	20.75	41.00	37.00	17.50	2.00
S36-02	55.75	51.75	23.88	41.81	37.81	17.91	2.00
S46-02	55.75	51.75	23.88	47.81	43.81	20.91	2.00
S62-02	67.75	63.75	29.88	66.00	62.00	30.50	2.00

“S11-02” OUTDOOR ERV AIRFLOW PERFORMANCE								
SUPPLY								
Blower RPM for S11, 1.5HP, Mist Eliminator Filter in Intake Hood								
		External Static Pressure (in water)						
		0	.25	.5	.75	1	1.25	1.5
CFM	300	n/a	n/a	1020	1205	1365	1480	1590
	500	n/a	1015	1200	1320	1460	1565	1670
	700	990	1190	1315	1455	1560	1665	1715
	900	1150	1310	1450	1555	1660	1680	1795
	1100	1305	1440	1550	1655	1740	1815	1895
EXHAUST								
Blower RPM for S11, 1.5HP, Barometric Hood, 2” Pleated Filters								
		External Static Pressure (in water)						
		0	.25	.5	.75	1	1.25	1.5
CFM	300	n/a	n/a	1150	1285	1415	1515	1640
	500	n/a	1145	1275	1410	1510	1545	1720
	700	1140	1270	1405	1505	1590	1715	1815
	900	1320	1435	1585	1665	1705	1810	1930
	1100	1495	1580	1660	1755	1880	n/a	n/a

“S20-02” OUTDOOR ERV AIRFLOW PERFORMANCE								
SUPPLY								
Blower RPM for S20, 2HP, Mist Eliminator Filter in Intake Hood								
		External Static Pressure (in water)						
		0	.25	.5	.75	1	1.25	1.5
CFM	1200	1065	1285	1375	1415	1495	1580	1685
	1400	1140	1330	1410	1440	1555	1660	1760
	1600	1290	1400	1480	1545	1670	1745	1835
	1800	1395	1470	1540	1665	1735	1800	1880
	2000	1460	1530	1650	1725	1795	1870	1960
EXHAUST								
Blower RPM for S20, 2HP, Barometric Hood, 2” Pleated Filters								
		External Static Pressure (in water)						
		0	.25	.5	.75	1	1.25	1.5
CFM	1200	1175	1290	1430	1520	1680	1765	1850
	1400	1245	1425	1515	1675	1755	1830	1920
	1600	1400	1505	1670	1750	1825	1910	1980
	1800	1495	1660	1740	1820	1900	1975	2090
	2000	1645	1730	1815	1895	1965	2080	2170

Notes:

1. Drive losses included in above tables.
2. Performances can vary depending on ambient conditions.
3. Blower RPMs are for reference only.

RPM Range

	Not available from pulley kits
	Low Speed (Factory Standard)
	Medium Speed
	High Speed

“S28-02” OUTDOOR ERV AIRFLOW PERFORMANCE								
SUPPLY								
Blower RPM for S28, 3HP, Mist Eliminator Filter in Intake Hood								
		External Static Pressure (in water)						
		0	.25	.5	.75	1	1.25	1.5
CFM	1200	n/a	955	1070	1210	1370	1465	1550
	1600	n/a	1065	1205	1305	1460	1540	1595
	2000	1060	1200	1290	1445	1530	1585	1680
	2400	1190	1335	1440	1490	1575	1670	1755
	2800	1300	1460	1550	1645	1705	1750	1800
EXHAUST								
Blower RPM for S28, 3HP, Barometric Hood, 2” Pleated Filters								
		External Static Pressure (in water)						
		0	.25	.5	.75	1	1.25	1.5
CFM	1200	n/a	n/a	1025	1170	1270	1355	1400
	1600	n/a	1020	1155	1240	1330	1390	1490
	2000	1015	1150	1235	1325	1380	1475	1590
	2400	1140	1285	1365	1420	1510	1595	1640
	2800	1280	1345	1455	1540	1575	1670	1745

“S36-02” OUTDOOR ERV AIRFLOW PERFORMANCE								
SUPPLY								
Blower RPM for S36, 3HP, Mist Eliminator Filter in Intake Hood								
		External Static Pressure (in water)						
		0	.25	.5	.75	1	1.25	1.5
CFM	2000	815	925	1020	1105	1155	1255	1325
	2400	920	1060	1130	1215	1250	1355	1385
	2800	1010	1140	1240	1285	1370	1425	1470
	3200	1125	1235	1340	1385	1455	1465	n/a
	3600	1225	1375	1440	1460	1500	n/a	n/a
EXHAUST								
Blower RPM for S36, 3HP, Barometric Hood, 2” Pleated Filters								
		External Static Pressure (in water)						
		0	.25	.5	.75	1	1.25	1.5
CFM	2000	755	890	970	1060	1125	1215	1280
	2400	985	1035	1085	1140	1240	1275	1325
	2800	1020	1115	1175	1230	1270	1335	1370
	3200	1105	1200	1225	1285	1300	1390	1430
	3600	1155	1265	1295	1335	1385	n/a	n/a

Notes:

1. Drive losses included in above tables.
2. Performances can vary depending on ambient conditions.
3. Blower RPMs are for reference only.

RPM Range

	Not available from pulley kits
	Low Speed (Factory Standard)
	Medium Speed
	High Speed

“S46-02” OUTDOOR ERV AIRFLOW PERFORMANCE								
SUPPLY								
Blower RPM for S46, 5HP, Mist Eliminator Filter in Intake Hood								
		External Static Pressure (in water)						
		0	.25	.5	.75	1	1.25	1.5
CFM	3000	965	1085	1150	1230	1295	1345	1420
	3400	1035	1145	1250	1290	1335	1415	1475
	3800	1120	1245	1285	1315	1440	1470	1535
	4200	1215	1305	1355	1430	1465	1530	1595
	4600	1300	1375	1450	1460	1540	1590	1650
EXHAUST								
Blower RPM for S46, 5HP, Barometric Hood, 2” Pleated Filters								
		External Static Pressure (in water)						
		0	.25	.5	.75	1	1.25	1.5
CFM	3000	1010	1105	1195	1255	1300	1375	1415
	3400	1100	1190	1250	1320	1370	1410	1480
	3800	1185	1245	1360	1410	1440	1475	1540
	4200	1240	1355	1425	1465	1530	1590	1630
	4600	1345	1410	1485	1520	1585	1650	1700

“S62-02” OUTDOOR ERV AIRFLOW PERFORMANCE								
SUPPLY								
Blower RPM for S62, 5HP, Mist Eliminator Filter in Intake Hood								
		External Static Pressure (in water)						
		0	.25	.5	.75	1	1.25	1.5
CFM	4600	795	900	1030	1075	1160	1220	1255
	5000	855	920	1070	1130	1190	1250	1275
	5400	880	950	1095	1155	1245	1270	1290
	5800	915	1035	1115	1175	1255	1280	n/a
	6200	985	1080	1135	1225	1265	n/a	n/a
EXHAUST								
Blower RPM for S62, 5HP, Barometric Hood, 2” Pleated Filters								
		External Static Pressure (in water)						
		0	.25	.5	.75	1	1.25	1.5
CFM	4600	705	885	985	1045	1100	1155	1215
	5000	825	950	1025	1095	1150	1210	1245
	5400	875	980	1080	1140	1190	1240	1275
	5800	935	995	1130	1180	1230	n/a	n/a
	6200	985	1095	1165	n/a	n/a	n/a	n/a

Notes:

1. Drive losses included in above tables.
2. Performances can vary depending on ambient conditions.
3. Blower RPMs are for reference only.

RPM Range

	Not available from pulley kits
	Low Speed (Factory Standard)
	Medium Speed
	High Speed

S SERIES ERV SUGGESTED SPECIFICATION

Furnish and install, at locations shown on plans or in accordance with schedule, mechanical cooling and/or heating system complete with a stand alone Energy Recovery Ventilator (ERV). The Energy Recovery Ventilator will contain an energy recovery component rated in accordance with ARI Standard 1060 with ratings certified by ARI. ERV shall be designed for ducting to the A/C (rooftop, upflow, horizontal) unit into the duct system of an air conditioning unit or as a stand alone unit with its own duct system. The cabinet shall be galvanized material with a powder coated paint finish electrostatically bonded to the metal. Cabinet panels where conditioned air is handled shall be fully insulated to prevent condensation and minimize sound. Openings shall be provided for duct connections. Lifting devices shall be provided for rigging. Test ports shall be provided so airflow can be measured across the energy recovery wheel. The intake and exhaust air blowers of the ERV shall contain a centrifugal forward curved blower. They shall have ball bearings with adjustable belt drive and motor mount base shall permit ease of motor change-over and belt tension adjustment.

The energy recovery device shall be a rotary heat exchanger per ARI Standard 1060 description. The device will be an enthalpy wheel coated with a silica gel desiccant by a patented process without the use of binders or adhesives which may plug the desiccant aperture. The substrate shall be a lightweight polymer. Desiccant shall not dissolve or deliquesce in the presence of water or high humidity. The wheel shall be easily cleanable with water and/or alkaline based coil cleaning solution. In all size units the wheel shall be provided with removable segments for cleaning and maintenance. All diameter and perimeter seals shall be provided. The energy recovery cassette shall be an Underwriters Laboratories Recognized Component for electrical and fire safety.

Barometric relief dampers will be provided in the exhaust air hood to prevent air infiltration if the ERV is de-energized. ERV unit to have mist eliminator filter in the intake air hood and 2" pleated filter on the return air side. ERV shall be provided with a single point power connection for high voltage. Energy Recovery Ventilator shall be Ruskin "S" Series.

OPTIONS (specifier select as required)

Roof Curb - Furnish and install the manufacturers' roof mounting curb to maintain the proper height above the roof.

Low Ambient Kit - Furnish and install a low ambient kit to prevent frost formation on the energy recovery wheel.

Motorized Intake Air Damper - Furnish and install motorized intake air damper.

Stop-Start-Jog - Furnish and install stop-start-jog controls to stop wheel rotation during economizer cycle operation.

Motorized Exhaust Air Damper - Furnish and install motorized exhaust air damper.

Disconnect - Furnish disconnect box for field installation.

Dirty Filter Switch - Furnish and install dirty filter switch.

Rotation Sensor - Furnish and install rotation sensor to verify wheel rotation.

Pressure Sensor - Furnish and install pressure sensor to confirm airflow performance.

Ruskin continually strives to improve our products, and reserves the right to change product design and specification without notice.

RUSKIN[®]

3900 Dr. Greaves Rd.
Kansas City, MO 64030
(816) 761-7476
FAX (816) 765-8955
www.ruskin.com

Printed on recycled paper
using vegetable based inks

