

## FSD37, FSD37LP COMBINATION FIRE AND SMOKE DAMPER

1½ HOUR UL555 RATED, UL555S LEAKAGE CLASS 1

### APPLICATION

Ruskin FSD37 Series ultra low leakage combination fire and smoke dampers provide point-of-origin fire and smoke containment. The FSD37 includes high strength one-piece airfoil blades to ensure the lowest resistance to airflow and are rated up to 2000 fpm (10.2 m/s) and 4 in. wg (1 kPa).

Ruskin FSD37LP ultra low leakage, low profile, and low pressure drop combination fire and smoke damper is provided with an integral sleeve/frame design. All FSD37 series dampers may be installed vertically in walls or horizontally in masonry floors and are rated for airflow and leakage in either direction.

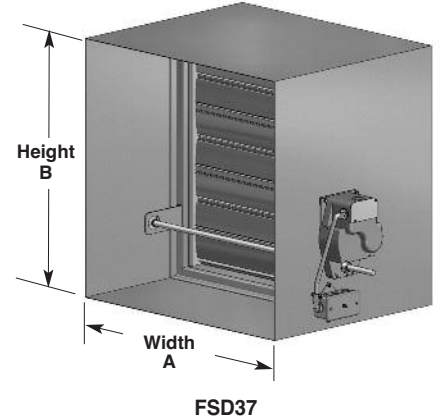

STANDARD CONSTRUCTION		
Description	FSD37	FSD37LP
<b>Frame</b>	5" x 16 gauge (127 x 1.6) galvanized, single piece, hat-shaped channel, structurally superior to 13 (2.4) gauge channel frame.	Integral sleeve and frame 20 (1.0) gauge galvanized single piece.
<b>Blades</b>	6" (152) wide and 16 (1.6) gauge galvanized steel. Blades are approximately 6" (152) on center.*	Low profile aerodynamic shaped, double skin of 16 (1.6) and 20 (1.0) gauge galvanized steel.
<b>Bearings</b>	Stainless steel sleeve type, pressed into frame.	Stainless steel sleeve type, pressed into frame.
<b>Jamb Seal</b>	Stainless steel, flexible metal compression type.	Stainless steel, flexible metal compression type.
<b>Blade Seal</b>	Silicone edge type for smoke seal to 450°F (232°C) and galvanized steel for flame seal to 1900°F (1038°C) mechanically fastened to the blade edge.	Stainless steel, flexible metal compression type.
<b>Linkage</b>	Concealed in frame.	Not Required

MAXIMUM OPERATIONAL RATINGS		
Description	FSD37	FSD37LP
<b>UL555S Leakage Rating</b>	Class I	Class I
<b>UL555 Hourly Rating</b>	1½ Hour	1½ Hour
<b>Maximum Velocity</b>	2000 FPM (10.2 m/s)	2000 FPM (10.2 m/s)
<b>Maximum Pressure</b>	4 in. wg (1 kPa)	4 in. wg (1 kPa)
<b>Temperature</b>	350°F (177°C)	350°F (177°C)

### OPTIONS

- **FM Approvals** as Specification Tested Product.
- **DTS** (Damper Test Switch) test switch for cycle testing.
- **TS150** for reopenable operation in dynamic smoke management systems.
- **DSDF/DSDN Duct Smoke Detector** (Flow rated or No-Flow).
- **SP100 Switch Package** to allow remote indication of damper blade position.
- **MCP** control panels for testing or monitoring purposes or smoke management systems.
- **Factory Sleeves** of various lengths and gauges to ensure field compliance with UL installation requirements. FSD37 only.
- **FAST Angle** factory supplied for labor saving angle one-side installation. Other angles of various sizes and gauges also available for one-side or two-side installation.
- **Stainless Steel Linkage** - 304 stainless steel.

### DAMPER SIZES

Sizes indicated below are for ratings of 2000 FPM (10.2 m/s) and 4 in. w.g. (1 kPa).

#### MINIMUM SIZE

- FSD37LP - 6"w x 6"h (152 x 152) (actual size)
- FSD37 - 8"w x 6"h (203 x 152)

#### MAXIMUM SIZE

- FSD37LP
  - Single Section Vertical or Horizontal – 36"w x 14"h (914 x 356)
- FSD37
  - Single Section Vertical – 32"w x 48"h (813 x 1219)
  - Single Section Horizontal – 30"w x 48"h (762 x 1219)
- FSD37
  - Multiple Section Vertical
    - 120"w x 96"h (3048 x 2438)
  - Multiple Section Horizontal
    - Electric Actuator – 120"w x 96"h (3048 x 2438)
    - Pneumatic Actuators – 144"w x 96"h (3658 x 2438)

#### CONTROLLED CLOSURE DEVICE (HEAT-ACTUATED)

- EFL** (Electric Fuse Link) - 165°F (74°C) standard. 212°F (100°C), 250°F (121°C), 350°F (177°C) available.
- PFL** (Pneumatic Fuse Link) - 165°F (74°C) standard. 212°F (100°C), 285°F (141°C) available.

### NOTES

1. Dampers are furnished approximately 1/4" (6) smaller than given opening dimensions.
2. Dimensions shown in parentheses ( ) indicate millimeters.

Models FSD37 series meets the requirements for smoke dampers established by:

- **National Fire Protection Association NFPA Standards** 80, 90A, 92A, 92B, 101 and 105
- **ICC International Building Codes**
- **CSFM California State Fire Marshal** Listing (#3235-0245:0127) • Listing (#3235-0245-0129)
- **New York City** (BSA Listing #176-82-SM)

# FSD37 AMCA LICENSED AIR PERFORMANCE DATA



Ruskin Company certifies that the FSD37 and FSD37LP shown hereon is licensed to bear the AMCA Seal. The ratings shown are based on tests and procedures performed in accordance with AMCA Publication 511 and comply with the requirements of the AMCA Certified Ratings Program. The AMCA Certified Ratings Seal applies to air performance for the FSD37.

To determine the AMCA Licensed air performance:

Locate the applicable feet per minute face velocity on the bottom of the velocity vs. pressure drop chart below. Move up the chart to the most appropriate size damper line. From the intersection point, move left to determine the pressure drop on the left side of the chart.

For other damper sizes refer to **Air Performance Data For All Fire and Smoke Dampers** spec sheet.

VELOCITY vs. PRESSURE DROP

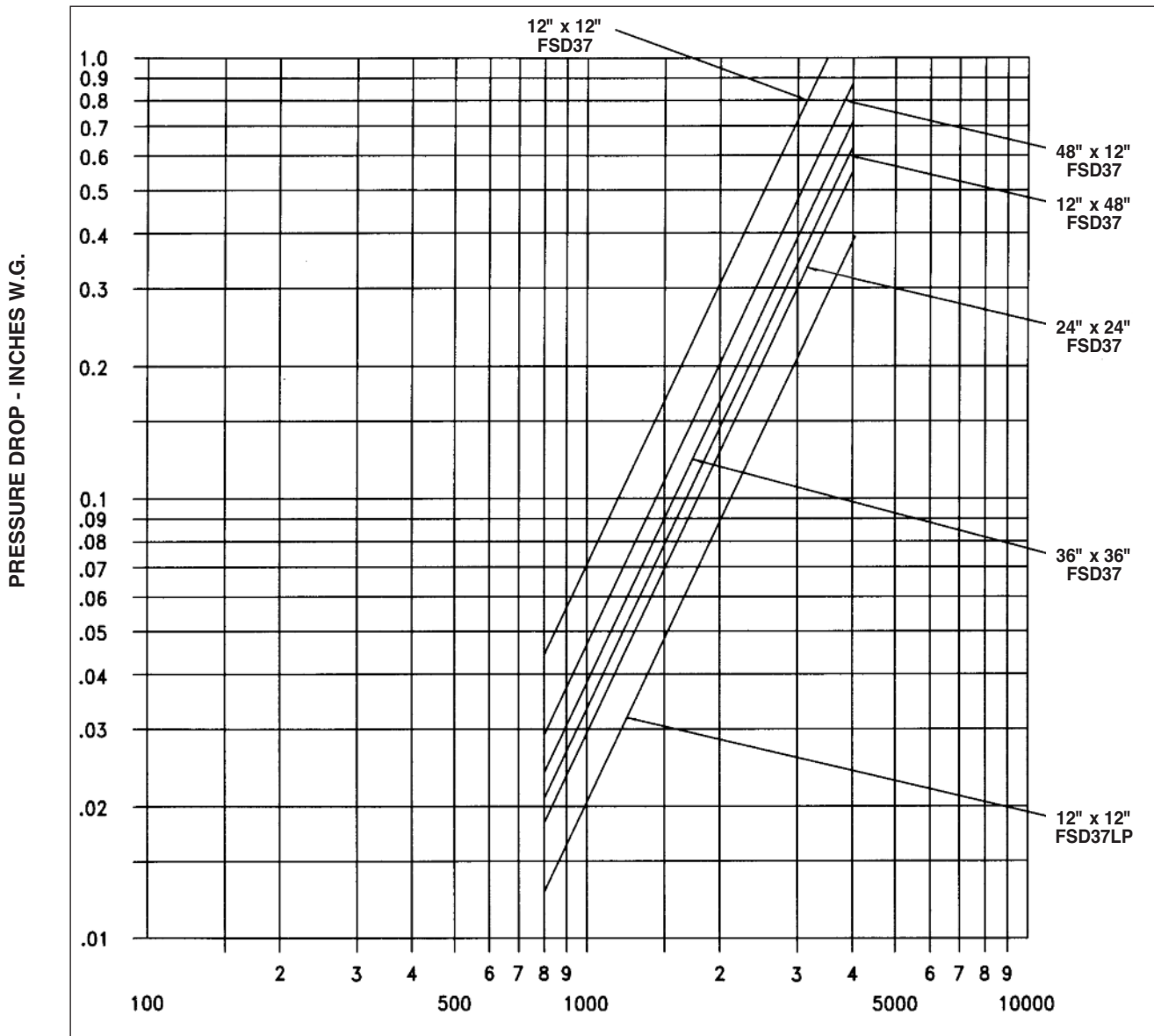

FACE VELOCITY - FEET/MINUTE  
AMCA Fig. 5.3

## EXTENDED OPERATIONAL RATINGS (FSD37 ONLY)

UL555S Test Standards require all fire and smoke dampers to prove closure and operation against heated air flow. The minimum ratings are 2,000 fpm (10.2 m/s) and 4" w.g. (1 kPa) and minimum of 250°F (121°C).

**Safety Factor** - UL555S has a built in safety factor of 400 fpm (2.03 m/s) and 0.5" w.g. (0.12 kPa). For example, to achieve a

dynamic closure rating of 2,000 fpm and 4 in wg the damper must operate against an actual airflow rate of at least 2,400 fpm (12 m/s) and pressure of at least 4.5" w.g. (1.12 kPa).

All Ruskin fire smoke dampers meet or exceed the minimum UL555S requirements.

2,000 FPM				
MODEL	SIZE	STATIC PRESSURE	TEMPERATURE	INSTALLATION
FSD37	120" x 96"	4" w.g.	350°	Vertical
FSD37	144" x 96"	4" w.g.	350°	Horizontal
FSD37LP	36" x 14"	4" w.g.	350°	Vertical or Horizontal

## ACTUATOR REQUIREMENTS

- \* UL555S requires that all combination fire smoke dampers have factory mounted actuators in order to bear the UL label.
- Fire smoke dampers larger than single section may require multiple actuators. See "Combination Fire Smoke Damper Multiple Section Detail" spec sheet for details.
- Ruskin's fire smoke dampers are UL555S labeled with either

electric or pneumatic actuators mounted internal (in air stream) or external (out of air stream).

- Fire smoke dampers utilizing multiple actuators must have all actuators **field** wired to a common point for simultaneous closure. All field wiring shall be in accordance with applicable codes, ordinances and regulations.

## FSD37LP SLEEVE DIMENSIONAL DATA

The drawing shows the standard position of the FSD37LP when installed. The mounting location provides enough space for the actuators, controls (FAST) retaining angles and duct connections. The minimum sleeve length is 20" (508). Consult Ruskin for shorter sleeve lengths.

### NOTES

1. The entire frame is not required to be installed within the wall or floor. The center line of the closed blade, should be contained within the wall or floor.
2. See basic UL installation instructions for complete installation requirements.

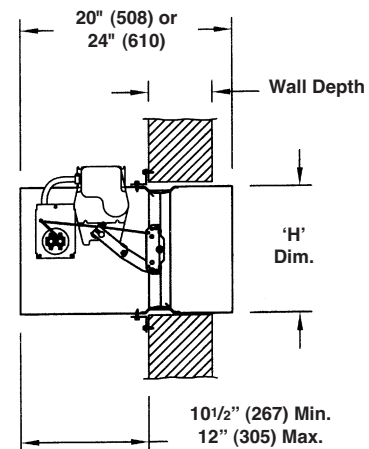

## FSD37 SLEEVE DIMENSIONAL DATA

The 'L' dimension is the distance from the end of the sleeve to the damper. The standard damper location in the sleeve provides enough space for the actuator, controls, mounting angles and duct connection. The standard sleeve length for FSD's is 20" (508) long and the standard 'L' dimension is 10<sup>5</sup>/<sub>8</sub>" (270). The standard 'L' dimension allows the end of the sleeve to be a minimum of 10<sup>5</sup>/<sub>8</sub>" (270) to the wall/floor and up to a maximum of 12<sup>1</sup>/<sub>2</sub>" (318) to the wall/floor.

\*The EFL, PFL, SP100 or TS150 location may be located above, below or on the side of the actuator depending upon the dampers height.

Optional 17" (432) long sleeve length available. Due to space limitations for actuators and controls with 17" (432) long sleeves, the damper height ('B' dimension) is restricted to the dimensions shown on the chart below. Consult Ruskin for other sleeve lengths.

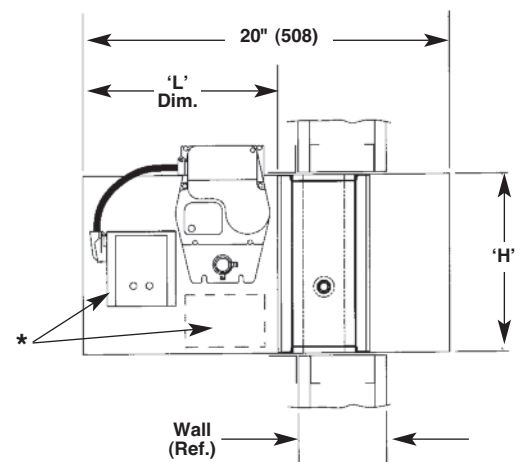

7 <sup>1</sup> / <sub>8</sub> " (181) 'L' Dim. for Sleeves Shorter than 20" (508) Long				
Without Accessories	Without Accessories (TS150, SP100 or DTS)			
Electric or Pneumatic Actuators	Electric Actuators	Pneumatic Actuators		
		331-4827	331-2961	331-3060
Over 10" (250) 'B' Dim.	Over 21" (533) 'B' Dim.	Over 28" (711) 'B' Dim.	Over 32" (813) 'B' Dim.	Over 40" (1016) 'B' Dim.

**NOTE:** The 21" (4533) dimension becomes 32" (813) when the MS4120, FSNF, FSAF and GGD series are utilized.

## FSD37 SERIES SPACE ENVELOPE

Combination fire smoke dampers are required by the UL listing to have all actuators and accessories factory mounted, wired and/or piped. The Ruskin standard is for the actuator to be located on the right hand side of the damper (onto a factory installed sleeve or side plate) as viewed from the jackshaft face of the unit. Larger units may require multiple actuators which are located on the right, left and maybe internal mount locations. See the "Multiple Section Detail" specification sheet for details. Ruskin's fire smoke dampers are not air flow directional, so the dampers may be rotated 180° or turned over as long as the blades are running horizontally in a position to accommodate installation obstructions.

The adjacent chart indicates an "S" and a "T" dimension for the space envelope that each actuator requires for installation. The "S" dimension is the "side" clearance, the "T" dimension is the "top" clearance required for the various actuators approved for use with Ruskin fire smoke dampers.

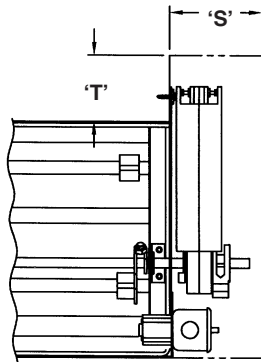

Ruskin recommends 6" (152) of additional space beyond the "S" dimension for ease of maintenance.

ACTUATORS	S	T
FSTF, FSLF	4" (102)	0" (0)
FSNF, FSAF, MS4120	5" (127)	5" (127)
331-4827	5" (127)	6" (152)
331-2961	8" (203)	8" (203)
331-3060	9" (229)	11" (279)

### NOTES

1. The dimensions shown in the chart above are for dampers 14" (356) tall.
2. Dampers shorter than 14" (356) tall, increase the "T" dimension by 1" (25) for every 1" (25) the damper is less than 14" (356).
3. Dampers taller than 14" (356) high reduce the "T" dimension by 1" (25) for every 1" (25) the damper height is greater than 14" (356).

### Example:

- a) 12" (305) tall damper with a FSLF actuator, "T" = 2" (52) and "S" = 4" (102).
- b) 18" (457) tall damper with a FSNF actuator, "T" = 1" (25) and "S" = 5" (127).

## FSD37 INTERNAL MOUNT ACTUATOR DIMENSION

Ruskin model FSD37 has been tested for internal mount actuators and accessories. These applications may be preferred where space is limited on the outside of the damper. Internally mounted actuators do not require the damper to have a factory installed sleeve or side plate.

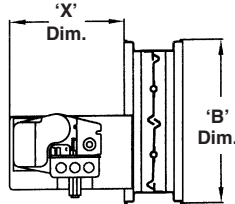
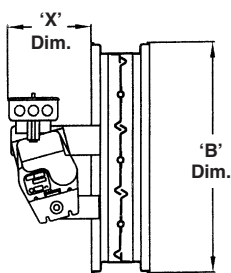

ACTUATORS	B Dim and Above		B Dim and Above	
	B	X	B	X
FSTF, FSLF	10" (154)	10" (154)	18" (457)	7 1/2" (191)
FSNF, FSAF, MS4120	12" (305)	12 3/4" (324)	21" (533)	5 1/2" (533)
331-4827	16" (406)	15" (381)	21" (533)	7 1/2" (191)
331-2961	16" (406)	17" (432)	24" (610)	7 1/2" (191)
331-3060	20" (508)	19" (483)	26" (660)	9" (229)

(Model FSD37LP not available with internal mount actuators)

# FSD37 DIMENSIONAL INFORMATION

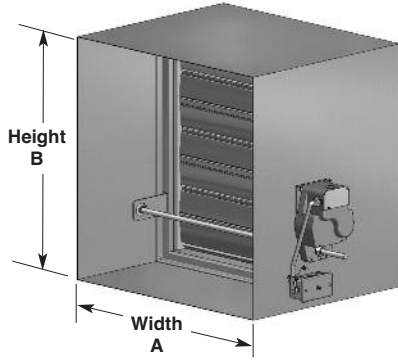

FSD37 Style A

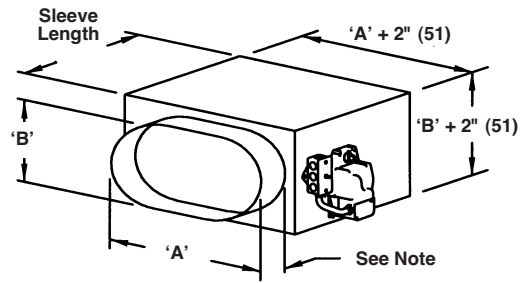

FSD37 Style LO,CO & WO  
FSD37LP Style LO & CO

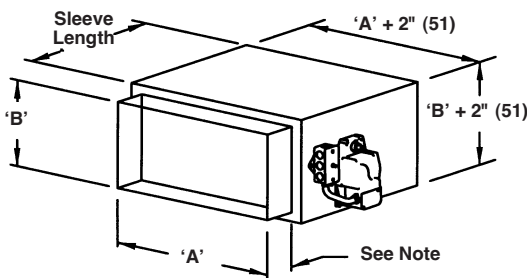

FSD37 Style C and WC  
FSD37LP Style C

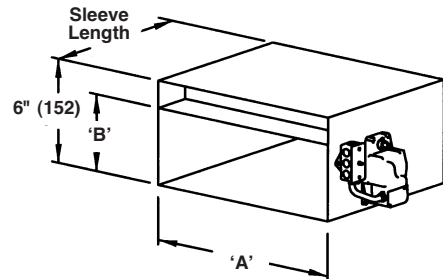

FSD37(LP) Style B

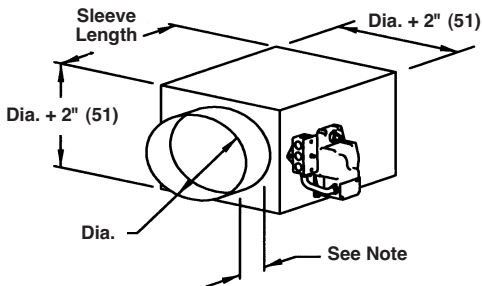

FSD37 Style R, CR and WR  
FSD37LP Style R & CR

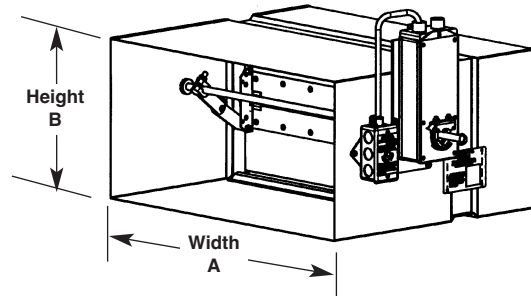

FSD37LP Style A

## DUCT TRANSITION CONNECTIONS

FSD37 Series dampers may be supplied with Round, Oval and Rectangular duct connections.

Style	Description
B	Units Under 6" Tall
R	Round Non-Sealed (Low Pressure)
CR	Round Sealed (Medium Pressure)
WR	Round Welded (High Pressure)
C	Rectangular Sealed (Low and Medium Pressure)
WC	Rectangular Welded (High Pressure)
LO	Oval Non-Sealed (Low Pressure)
CO	Oval Sealed (Medium Pressure)
WO	Oval Welded (High Pressure)

The square damper size will be 2" (51) larger in width and height than the round, oval or rectangular duct size ordered.

Approximate damper assembly weight: 17 lbs. per sq. ft. for Style A

## MINIMUM and MAXIMUM SIZES

### Round Transitions

Minimum 4" (102) diameter  
Maximum 94" (2388) diameter

### Rectangular and Oval Transitions

Minimum 6"w x 4"h (152 x 102)  
Maximum 118"w x 94"h (2997 x 2388) in diameter

### 'B' Style Transitions

Minimum height 4" (102) 'B' style transitions are utilized on units where the damper height is less than 6" (152).

Consult Ruskin for other available styles and sizes.

**Note:** For low and medium pressure units (Styles R, CR, C and CO) the collar extends 1 1/2" (38) beyond the sleeve length and for low pressure and high pressure units (Styles R, WR, WC and WO) the collar extends 2 1/2" (64) beyond the sleeve length.

## SPECIFICATION

---

Combination fire smoke dampers meeting or exceeding the following specifications shall be furnished and installed at locations shown on plans or as described in schedules. Combination fire smoke dampers shall be produced in an ISO 9001 certified factory and shall be warranted to be free from defects in material and workmanship for a period of 5 years after date of shipment. Dampers shall meet the requirements of NFPA80, 90A, 92A and 92B and shall have a fire rating of 1½ hours in accordance with the latest edition of UL555 and shall be classified as Leakage Class I Smoke Dampers in accordance with the latest version of UL555S. Dampers shall be AMCA Licensed and the product literature shall bear the AMCA certified rating seal for air performance. AMCA certified testing shall verify pressure drop does not exceed .03" w.g. on a 12" x 12" (305 x 305) damper at a face velocity of 1000 fpm.

Damper frame (when size permits) shall be constructed using the UniFrame Design Concept (UDC) and shall be minimum 16 gauge (1.6) galvanized steel formed into a structural hat channel superior to 13 gauge (2.4) channel frame. Assemblies less than 36" (914) wide x 14" (356) high shall be Low Profile (LP) design to maximize the free area of these smaller dampers. Damper blades shall be single piece airfoil shaped with 14 (2.0) gauge equivalent thickness and units less than 36" (914) wide x 14" (356) high low profile aerodynamic shaped, double skin 16 (1.6) and 20 (1.0) gauge galvanized steel. Blade edge seals shall be inflatable silicone mechanically locked into blade edge and units less than 36" (914)

wide x 14" (356) high stainless steel, flexible metal compression type. Jamb seals shall be stainless steel compression type. Bearings shall be stainless steel, permanently lubricated sleeve type turning in an extruded hole in the frame for maximum life.

Combination fire smoke dampers and their actuators shall be qualified in accordance with UL555S to an elevated temperature of 250°F (121°C) or 350°F (177°C) depending upon the actuator. Appropriate electric or pneumatic actuators (**specifier select one**) shall be installed by the damper manufacturer at time of damper fabrication. Electric actuators, factory installed on dampers, shall have been tested for prolonged periods of holding (minimum 1 year) with no evidence of reduced spring return performance. Each damper shall be rated for leakage and airflow in either direction through the damper. In addition to the leakage ratings already specified, the dampers shall be AMCA licensed for Air Performance.

### Optional FM Approvals Specification

Each combination fire smoke damper shall be listed in Factory Mutual (FM) approvals Specification Tested Product and labeled accordingly.

Combination fire smoke dampers shall be Ruskin FSD37 Series and units less than 36" (914) wide x 14" (356) high model FSD37LP. (Consult [www.ruskin.com](http://www.ruskin.com) for electronic version of this "Quick" spec as well as for complete 3-part CSI MasterFormat Specifications)

**RUSKIN**®

3900 Dr. Greaves Rd.  
Kansas City, MO 64030  
(816) 761-7476  
FAX (816) 765-8955  
[www.ruskin.com](http://www.ruskin.com)