

FD35GA AND FD35SSGA "OUT OF THE WALL" GRILLE ACCESS MULTIPLE BLADE FIRE DAMPER

1½ HOUR RATING UL555 RATED FOR USE IN "STATIC" SYSTEMS

APPLICATION

Ruskin FD35GA and FD35SSGA 1½ hour static rated fire dampers are designed for "out of wall" applications. The damper assembly can be installed completely from one side of the wall and does not require mounting angles on the backside. The FD35GA and FD35SSGA dampers allow through the grille access to the damper, permits access to the damper fusible link assembly. Dampers may be installed vertically (in walls) in HVAC systems with airflow in either direction.

STANDARD CONSTRUCTION

FRAME

FD35GA – 5" x 1" x 16 gage (127 x 25 x 1.52) galvanized steel hat channel, structurally superior to 13 gage (2.3) channel frame.

FD35SSGA – 5" x 1" x 16 gage (127 x 25 x 1.52) 304 or 316 stainless steel hat channel frame.

BLADES

16 gage (1.52) galvanized, 340 or 316 stainless steel triple vee-groove, approximately 6" (152) on center.

BEARINGS

Stainless steel sleeve, pressed into frame.

LINKAGE

Concealed in frame.

AXLES

½" (13) plated steel hex.

FUSIBLE LINK

165°F (74°C) standard or 212°F (100°C) available.

DAMPER WEIGHT

Approximately 18 lbs. per sq. ft.

DAMPER SIZES

MINIMUM SIZE

Vertical Installation – 8"w x 6"h (203 x 152)

MAXIMUM SIZE

Single Section

FD35GA Vertical Installation – 36"w x 36"h (914 x 914)

FD35SSGA Vertical Installation – 30"w x 36"h (762 x 914)

Multiple Sections

FD35SSGA Vertical Installation – 36"w x 36"h (914 x 914)

OPTIONS

- **FM Approvals** as Specification Tested Product.
- **SP100 Switch Package** to remotely indicate damper blade position.
- **FAST Angle** for one side angle installation.
- **Sleeve** of various lengths and gages to ensure field compliance with UL installation requirements.
- **Jamb Seals** stainless steel flexible metal compression type.
- **Blade Seals**, Silicone blade edge seals.
- **Crank Lever** to assist with testing and fuse link replacement
- **OW, Out of Wall** of application where the damper can not be installed within the plane of the wall or floor.

NOTES:

1. Dimensions in inches, parentheses () indicate millimeters.
2. Damper/sleeve assembly furnished actual size.

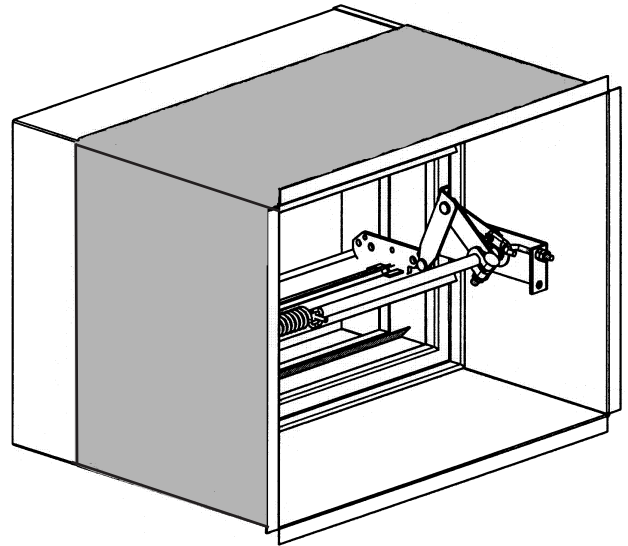

The FD35GA and FD35SSGA dampers meet the requirements for fire dampers established by:

- **National Fire Protection Association NFPA Standards** 90A, 92A, 92B and 101
- **ICC International Building Codes**
- **CSFM California State Fire Marshal Listing #3225-245:005**



FM Approvals
Specification Tested Product
(Option)

TYPICAL INSTALLATION

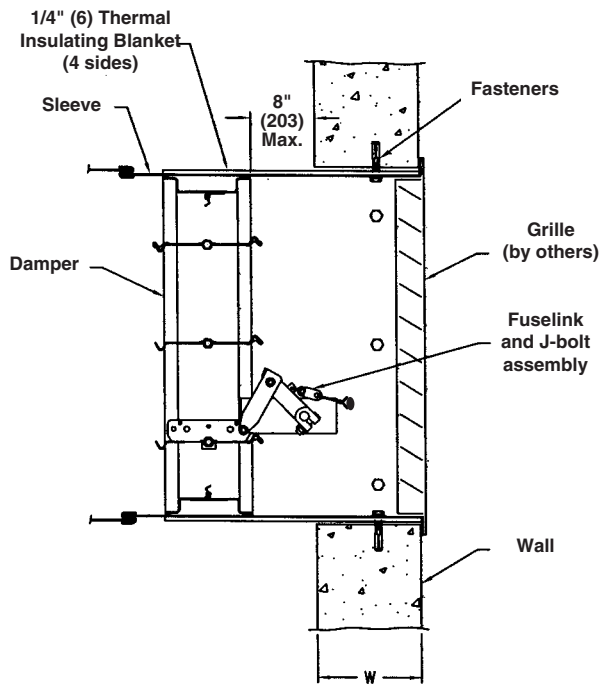

Wall Opening

The opening in the wall shall be sized to accommodate the overall size of the damper, sleeve and insulation assembly. No expansion gap is required.

For proper installation, frame and finish the opening so it is 1/2" (13) larger in width and 1/2" (13) larger in height than the duct size.

For example a 24" w x 20"h (610 x 508) damper requires a wall opening of 24 1/2"w x 20 1/2"h (622 x 521). The damper/sleeve to duct connection remains 24"w x 20"h (610 x 508) and is the dimension used for grille considerations.

Sleeve Length

1. Ruskin standard sleeve length is 16" (406) based on a grille depth of 2" (51) and duct connection of 1 1/2" (38).
2. Add 1" (25) to sleeve length for every 1" (25) of additional grille depth. For example, a grille depth of 4" (102) requires a minimum sleeve length of 18" (457).
3. Consult Ruskin if sleeve lengths less than 16" (406) are required.

Note: Damper may not be outside wall/floor more than 8" (203).

SUGGESTED SPECIFICATION (FD35GA and FD35SSGA)

Furnish and install at locations shown on plans or as described in schedules AMCA Certified fire dampers constructed and tested in accordance with UL Safety Standard 555 that meet or exceed the following specifications. Fire Dampers shall be produced in an ISO 9001 certified factory.

Damper frame, where size permits, shall be constructed using Uniframe Design Concept (UDC) and shall be minimum 16 gage (1.52) galvanized steel (or stainless steel) formed into a structural hat channel superior to 13 gage (2.30) channel frame. Top and bottom frame members on dampers less than 13" (330) high shall be low profile design to maximize the free area of these smaller dampers. Damper blades shall be single skin 16 gage (1.52) galvanized steel (or stainless steel) with three longitudinal grooves for reinforcement. Bearings shall be stainless steel turning in an extruded hole in the frame for maximum life.

Each fire damper shall have a 1 1/2 hour fire protection rating and shall be supplied with a 165°F (74°C) or 212°F (100°C) fusible link.

Fire dampers shall be approved for vertical or horizontal mounting as required by the location shown and shall be installed using steel sleeves, angles and other materials and practice required to provide an installation in accordance with the damper manufacturer's installation instructions. In addition, the fire dampers shall be AMCA licensed for air performance and shall bear the AMCA Certified Ratings Seal.

The FD35GA and FD35SSGA carries a 1 1/2 hour UL fire damper label and is classified as a static damper for use in HVAC systems that shut down during a fire.

Optional FM Approvals Specification

Each fire damper shall be listed in Factory Mutual (FM) Approvals Specification Tested Product and labeled accordingly.

Dynamic fire dampers shall be Ruskin model FD35GA or FD35SSGA.

(Consult www.ruskin.com for electronic version of this "Quick" spec as well as for complete 3-part CSI MasterFormat Specifications)

RUSKIN®

3900 Dr. Greaves Rd.
Kansas City, MO 64030
(816) 761-7476
FAX (816) 765-8955
www.ruskin.com

Printed on recycled paper
using vegetable based inks

