

DFD35/OW and DFD35SS/OW "OUT OF WALL OR FLOOR" FIRE DAMPER

1½ HOUR RATING FOR USE IN STATIC & DYNAMIC SYSTEMS

APPLICATION

Ruskin DFD35/OW and DFD35SS/OW 1½ hour dynamic rated fire dampers are designed for "out of the wall or floor" installation. The DFD35/OW and DFD35SS/OW are designed for "through penetration" or "duct termination" with the damper up to 8" (203) out of the plane of the wall or floor. The DFD35/OW is constructed of galvanized steel and the DFD35SS/OW is constructed of 304 or 316 stainless steel. All models are wrapped with an insulating material around the assembly.

DYNAMIC CLOSURE RATINGS

MAXIMUM VELOCITY – 2,000 fpm (10.15 m/s) on all sides.

MAXIMUM pressure – 4 in. w.g. (kPa).

STANDARD CONSTRUCTION

FRAME

5" x 1" x 16 gage (127 x 25 x 1.52) galvanized or stainless steel hat channel, structurally superior to 13 gage (2.3) channel frame.

BLADES

6" (152) wide, 16 gage (1.52) galvanized, 304 or 316 stainless steel, approximately 6" (152) on center.

BEARINGS

Stainless steel sleeve, pressed into frame.

BLADE SEALS

Blade edge overlap for flame seal to 1900°F (1083°C).

LINKAGE

Concealed in frame.

AXLES

½" (13) plated steel hex or 300 series stainless steel.

FUSIBLE LINK

165°F (74°C) standard. 212°F (100°C) available.

SLEEVE

20 (1.0) gage galvanized steel factory installed with thermal insulation on four sides.

DAMPER WEIGHT

Approximately 18 lbs. per sq. ft.

DAMPER SIZES

MINIMUM SIZE

DFD35/OW and DFD35SS/OW – 8"w x 6"h (203 x 152).

MAXIMUM UL CLASSIFIED SIZES

DFD35/OW –

Single section vertical and horizontal installation – 36"w x 36"h (914 x 914).

DFD35SS/OW –

Single section vertical and horizontal installation – 36"w x 36"h (914 x 914).

OPTIONS

- **FM Approvals** as Specification Tested Product.
- **SP100 Switch Package** to remotely indicate damper blade position.
- **Sleeve** of various lengths and gages to ensure field compliance with UL installation requirements.
- **Jamb Seals** stainless steel flexible metal compression type.
- **Blade Seals** Silicone blade edge seals.
- **FAST Angle** for one side angle installation.
- **PFMA Angles** for two side angle installation.
- **Crank Lever** to assist with testing and fuse link replacement
- **GA, Grille Access** for one side installation and "out of wall" applications (see models IBD2GA or DIBD2GA).

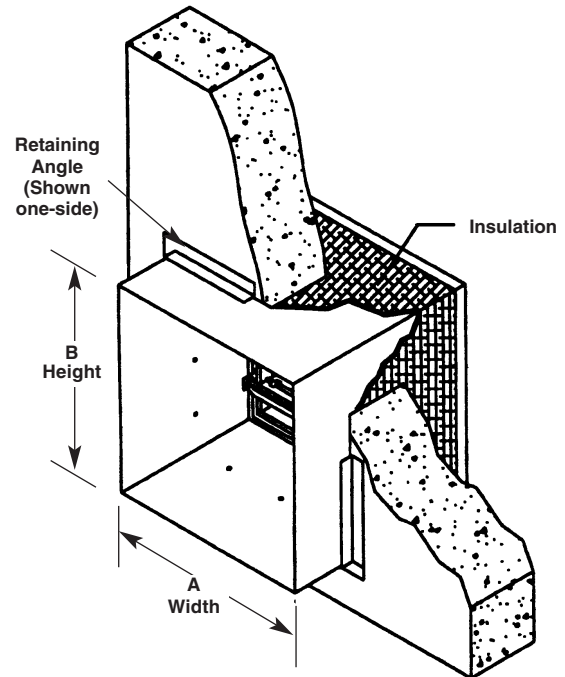

Ruskin DFD35/OW and DFD35SS/OW dampers meet the requirements for fire dampers established by:

- **National Fire Protection Association NFPA Standards** 90A, 92A, 92B and 101
- **ICC International Building Codes**
- **CSFM California State Fire Marshal Listing** #3225-245:005



SEE COMPLETE
MARKING
ON PRODUCT

UL555 Classification R5531



NOTES:

1. Dimensions in inches, parentheses () indicate millimeters.
2. Unit furnished approximately ¼" (6) smaller than given opening dimensions.

ORIENTATION

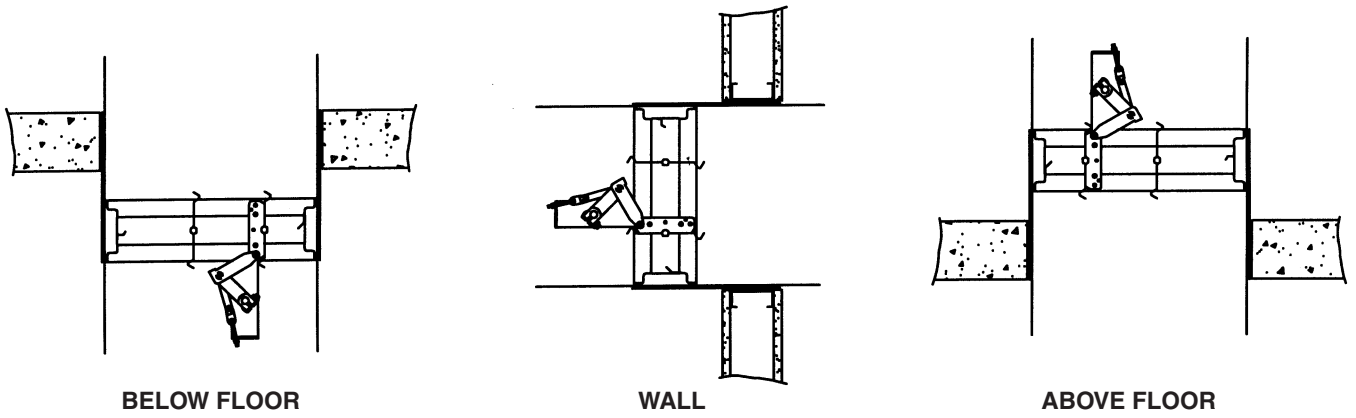

SLEEVE TRANSITION DIMENSIONAL DATA

DUCT TRANSITION CONNECTIONS

FD35SS dampers may be supplied with Round, Oval and Rectangular duct connections.

Style	Description
BC	Units Under 6" (152) Tall
WR	Round Welded (High Pressure)
WC	Rectangular Welded (High Pressure)
WO	Oval Welded (High Pressure)

The square damper size will be 2" (51) larger in width and height than the round, oval or rectangular duct size ordered.

MINIMUM and MAXIMUM SIZES

WR Round Transitions

Minimum 6" (152) diameter
Maximum 34" (864) diameter

WO Rectangular and Oval Transitions

Minimum 6" x 4" (152 x 102) diameter
Maximum 34" x 32" (864 x 813) diameter

'BC' Style Transitions

Minimum height 4" (102) 'B' style transitions are utilized on units where the damper height is less than 6" (152).

Consult Ruskin for other available styles and sizes.

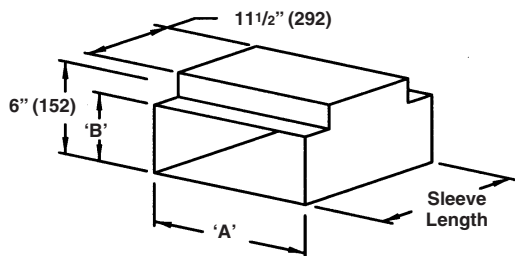

Style BC

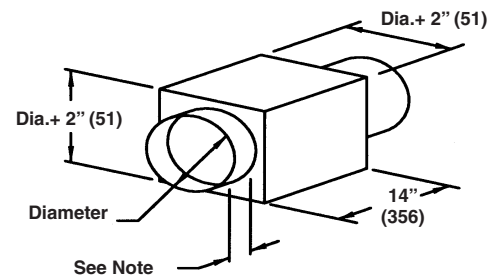

Style WR

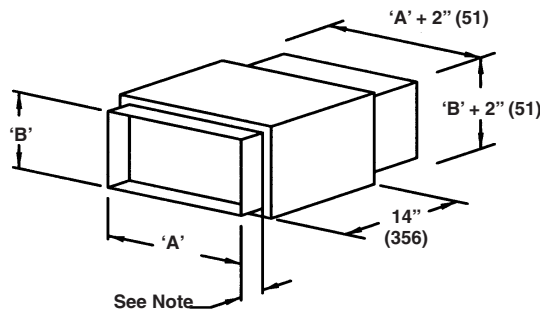

Style WC

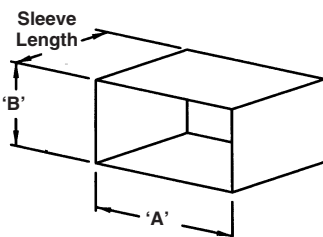

Style A

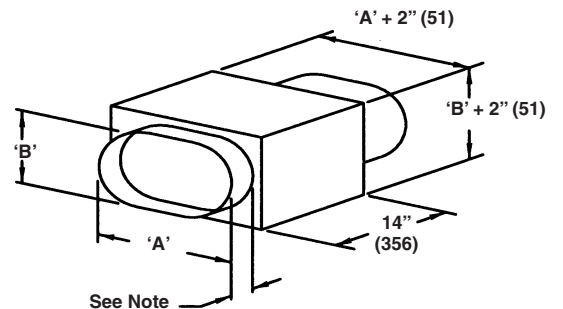

Style WO

DAMPER SLEEVE DIMENSIONAL DATA

The drawings show the position of the damper mounted in the factory sleeve. The standard location permits the damper to be installed outside the plane of the wall or floor. For damper styles WR, WC, WO and BC only the duct connection portion extends through the wall and the damper assembly is mounted flush with the wall.

(Note: For grille type installation, omit the 3 1/2" (89) sleeve extension.)

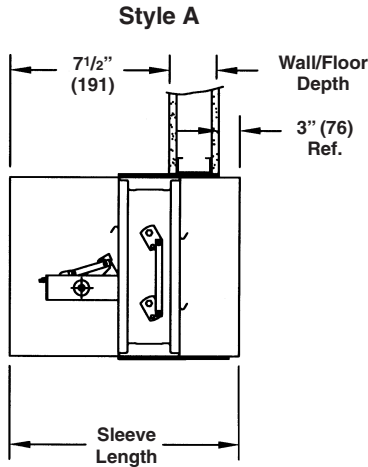

STYLE A
SLEEVE LENGTH FORMULA:
 To determine correct sleeve length necessary:
 Add wall or floor depth 7 1/2" (191) + 3" (76)
Example:
 Wall depth 4 1/2" (114) + 7 1/2" (191) + 3" (76) = 15" (381)

STYLE BC
SLEEVE LENGTH FORMULA:
 To determine correct sleeve length necessary:
 Add wall or floor depth + 14" (356) + 3" (76)
Example:
 Wall depth 4" (102) + 14" (356) + 3" (76) = 21" (533)

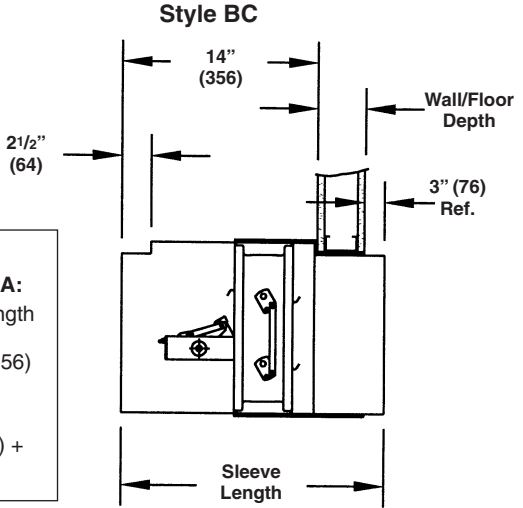

STYLE W, WC & WO SLEEVE LENGTH FORMULA:
 To determine correct sleeve length necessary:
 Add wall or floor depth 16" (406) + 3" (76)
Example:
 Wall depth 4" (102) + 16" (406) + 3" (76) = 23" (584)

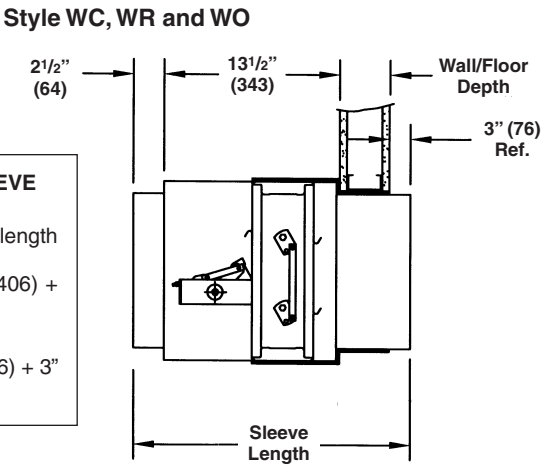

SUGGESTED SPECIFICATION

Furnish and install at locations shown on plans or as described in schedules AMCA Certified fire dampers constructed and tested in accordance with UL Safety Standard 555 that meet or exceed the following specifications. Fire Dampers shall be produced in an ISO 9001 certified factory.

Damper frame, where size permits, shall be constructed using Uniframe Design Concept (UDC) and shall be minimum 16 gage (1.52) galvanized steel [or stainless steel] formed into a structural hat channel superior to 13 gage (2.30) channel frame. Top and bottom frame members on dampers less than 13" (330) high shall be low profile design to maximize the free area of these smaller dampers. Damper blades shall be single skin 16 gage (1.52) galvanized steel [or stainless steel] with three longitudinal grooves for reinforcement. Bearings shall be stainless steel sleeve turning in an extruded hole in the frame for maximum life.

Each fire damper shall have a 1 1/2 hour fire protection rating and shall be supplied with a 165°F (74°C) or 212°F (100°C) fusible link. Sub-

mittal information shall include the fire protection, maximum velocity and pressure ratings and the manufacturer's UL installation instructions.

Fire dampers shall be approved for vertical or horizontal mounting as required by the location and are approved for installation "out of the wall or floor." Dampers shall be installed using steel sleeves, angles and other materials and practice required to provide an installation in accordance with the damper manufacturer's installation instructions. In addition, the fire dampers shall be AMCA licensed for air performance.

Each fire damper shall be labeled for use in dynamic systems. Static only damper labels are not permissible. The damper shall be rated for dynamic closure at 2000 fpm (10.2 m/s) and 4" w.g. (1 kPa) static pressure and shall be tested and rated to close with airflow in either direction.

Fire dampers shall be Ruskin model DFD35/OW (or DFD35SS/OW). (Consult www.ruskin.com for electronic version of this "Quick" spec as well as for complete 3-part CSI MasterFormat Specifications)



3900 Dr. Greaves Rd.
 Kansas City, MO 64030
 (816) 761-7476
 FAX (816) 765-8955
www.ruskin.com

Printed on recycled paper using vegetable based inks