

FSDPC INTELLIGENT PANEL PC WITH TOUCHSCREEN MONITOR

APPLICATION

Ruskin model FSDPC is the heart of the Ruskin Inspector™ system. The FSDPC control panel is equipped with a Windows embedded operating system that is fully programmed and ready for commissioning. The Panel PC has no moving parts, making it extremely reliable for continuous service. Model FSDPC will continuously monitor and log all activity for up to 500 devices on the network. The touch screen monitor makes viewing the current health and status of each device simple. Navigate through each group of devices with an intuitive graphical user interface (GUI). Testing of all devices on the network is fully automated. The data log records all activity, providing necessary test report documentation for use of Authorities Having Jurisdiction (AHJ). The building automation system can connect with all devices on the Ruskin Inspector™ network through one data point, saving points on the BAS controller, additional equipment and installation cost.

STANDARD CONSTRUCTION

NEMA 1 ENCLOSURE

20" w x 16" h x 8" d (508 x 406 x 203) nominal
18 Ga. (1.3mm) mild steel with powder coat finish

PANEL PC

12" (305) Atom based embedded PC
2GB ram, 4 GB compact flash drive (CFD)

MONITOR

High resolution, panel mount, full color, touch screen

DIGITAL CONTROLLER

D1804 I.O. factory wired in panel

ROUTER

1-way, 2-way or 4-way router as required

EMERGENCY BATTERY BACKUP

UPS with integrated power supply and maintenance-free rechargeable battery.

SUPPLY

120 VAC, 50/60 Hz
750 VA maximum power consumption

INPUTS

(8) Non-isolated dry contacts
Sense Current 15mA at 12 VDC

OUTPUTS

(4) SPCO mechanical relay contacts
1 A at 230 VAC maximum switch load



Environmental Ratings

Operating 0° to 104° F (0° to 40° C)
Storage 5° to 113° F (-15° to 45° C)
Humidity 80% RH to 87° F (31° C) decreasing
Linearly to 50% RH at 104° F (40° C)
6,562 ft (2000m) maximum altitude

VARIATIONS

- Flush Mount Panel
- Customized programming
- Commissioning service

Notes:

1. Dimensions shown in () indicate metric units.
2. Refer to installation manual for additional details
3. US Patent No. 7,241,218

DIMENSIONAL DETAILS

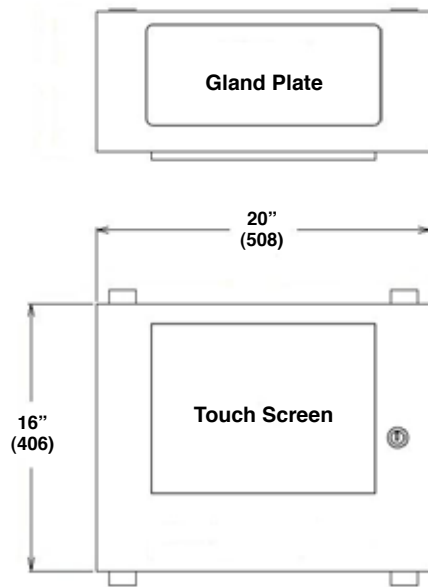

Notes:

1. Remove gland plate prior to drilling or punching conduit holes for electrical connections.
2. Dimensions are nominal
3. Dimensions in parenthesis () indicate millimeters.



INSTALLATION DETAILS

MOUNTING

- Only use the mounting brackets provided.
- The height of the unit above the floor level should be chosen so that the center of the PC is just above normal eye level (approximately 5' (1.5m)).
- The unit should be placed in a naturally vented area and this area should be considered fire safe and free from high levels of shock and vibration.
- Conditions should not arise which may allow the temperature in this area to reach or exceed the operating temperature of the unit.
- Do not locate the unit where access to its internal components and connections are restricted.
- Flush mounted panel option available.

WARNING: Observe all health and safety procedures when lifting or moving this equipment.

PREPARATION

- Only trained and qualified personnel should be allowed to install, replace or service this equipment. Installation should be in accordance with the relevant local safety standards.
- The mains wiring should comply with IEC 60227 or IEC 60245.
- * A switch or circuit breaker should be included as part of the installation.
- The switch or circuit breaker should meet the relevant requirements of IEC 60947-1 and IEC 60947-3.
- The switch or circuit breaker should be in close proximity to the equipment and be within easy reach of the operator.
- The switch or circuit breaker should be marked as the disconnecting device for the equipment and should disconnect both poles of the supply.
- The switch or circuit breaker should not interrupt the protected earth conductor.
- This equipment **MUST** be earthed.

WIRING DETAILS

INSTALLATION

1. Disconnect the local supply before commencing any work on this equipment.
2. Wire the mains supply feed in accordance with wiring diagram 1 shown (right). When complete, secure the mains cable using the cable gland.
3. Wire the incoming mains cable in accordance with wiring diagram 2.
4. Wire the incoming live (black) and neutral (white) wires to the mains terminal.
5. Connect the incoming earth wire to the protected earth stud using a ring connector. This connector must be fitted and secured independently using the shake proof washer and nut provided. The floating panel earth wire should be connected on top of this using the additional shake proof washer and nut provided.
6. The mains cable should be fitted in such a manner that, should the cable be subject to strain, the earth wire would be the last wire to break loose.
7. Finally, the mains wires should be tie wrapped to prevent slippage. Once wiring is complete, apply power to the equipment.

INPUTS

- The volt free input terminals are numbered 201, 202, 203, etc.
- Wire the first input as shown across and repeat for subsequent inputs.
- Please note that inputs are not optically isolated.
- The input cable diameter should be 18 or 16 AWG (1mm² or 1.5mm²)
- Limit cable runs to 330 ft (100m) and avoid running input cables near sources of mains or noisy environments.

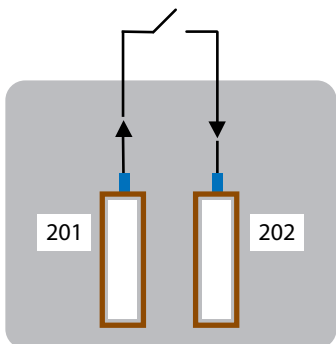

INPUT	TERMINAL NUMBER
INPUT 1	201, 202
INPUT 2	203, 204
ETC.	

WIRING DIAGRAM 1

(Mains supply feed)

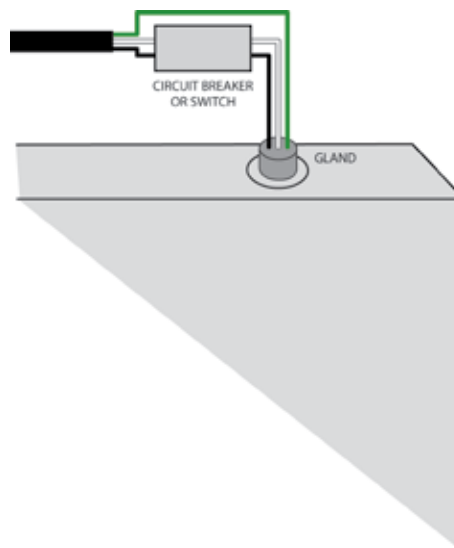

WIRING DIAGRAM 2

(Incoming mains cable)

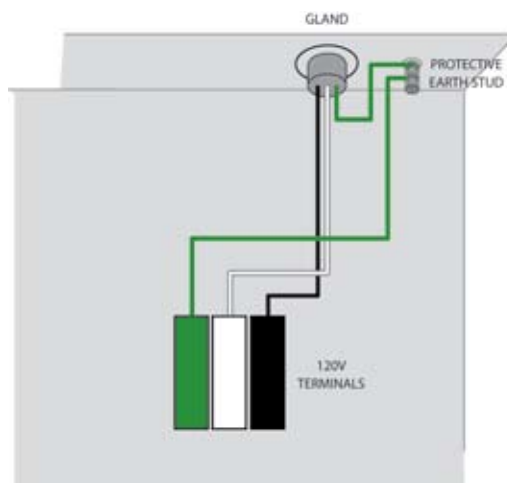

INPUT WIRING

WIRING DETAILS

OUTPUTS

- The relay output terminals are numbered 401, 402, 403, etc.
- Wire the first output as shown across and repeat for subsequent outputs.
- It is the user's responsibility to ensure the switched equipment is adequately protected.
- As a precautionary measure, a standard 1 AT fuse is used to protect each output irrespective of it switching 24V or mains. The value of this fuse may have to be modified in accordance with the user's requirements. The user is responsible for the replacement policies of any fuses whose value deviates from the standard 1 AT fuse supplied.
- The non-fused terminals 401, 403, 405, etc. should be regarded as the output terminals to the switched equipment.
- The fused terminals 402, 404, 406, etc. should be regarded as the input terminals from the switched equipment. The two terminal wires from each output should be tie wrapped together to prevent slippage.

NETWORKS

- The network terminals are numbered 101, 102, etc. These free topology networks are internally terminated.
- Wire the first network as shown across and repeat for subsequent networks.
- The network cables must not run alongside any high voltage or high frequency sources. Also, network cables must not be mixed on an individual network as they have very different electrical characteristics and could render the system unreliable.
- Use unshielded 1 pair Cat 5e/24AWG stranded or plenum rated 4 pair Cat 5e/24AWG.
- Maximum length between devices should not exceed 820 ft.
- Maximum length per network channel not to exceed 1,500 ft.

SUGGESTED SPECIFICATION

To support NFPA and fire code requirements for scheduled testing, all fire, smoke and combination fire/smoke dampers shall be wired to a monitoring and testing system (MTS) capable of continuously monitoring the health and status of all life safety devices within the network. The MTS shall have an automated testing feature with a 24 hour integrated time clock to facilitate staged testing during scheduled shut down events. The system shall also include a manual test feature to facilitate inspection of a single damper within the network. MTS shall be connected to a set of contacts at each device. Contacts shall be linked directly to damper blades to ensure positive blade position. MTS shall be programmed and commissioned by a factory authorized commissioning agent following established ISO9001 standards. MTS shall include atom based embedded PC with minimum 2 GB random access memory and 4 GB compact flash drive. The MTS shall be housed in a NEMA1 rated 18 gage mild steel enclosure with powder coat finish. Enclosure shall have a keyed hinged cover for easy access to the internal components. The complete life safety damper network shall be accessible through a panel mount touch screen located in the enclosure cover. The MTS shall incorporate a Windows based graphical user interface (GUI) with symbols for each device in the life safety network. Life safety products shall be grouped by area and or floor. Home page GUI shall show each respective group within the network. Touching a group icon shall result in displaying individual icons representing all life safety devices within that group. Touching an individual device icon shall result in displaying current health and status of the device. Icon colors shall indicate good health (green) and poor health (red) for quick review of system health. MTS shall continuously monitor and communicate all data points within the MTS network to the building automation system (BAS) if required. MTS shall include Panel PC with touchscreen monitor, digital controller, all necessary routers, and emergency battery backup factory installed in a NEMA1 rated enclosure as specified above. MTS shall be compatible with life safety dampers that include a damper interface. All dampers in the system shall be manufactured, for use with the MTS, in an ISO9001 certified facility. MTS shall be in all respects equal to Ruskin model FSDPC.

OUTPUT WIRING

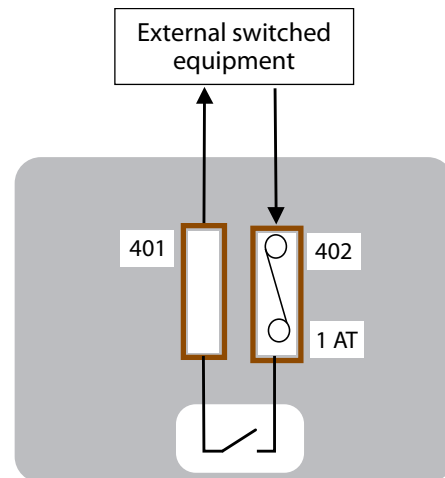

OUTPUT	FEED (FUSED) TERMINAL	RETURN TERMINAL
OUTPUT 1	402	401
OUTPUT 2	404	403
ETC.		

NETWORK WIRING

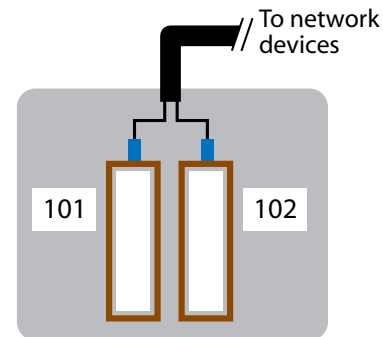

NETWORK	TERMINAL NUMBER
NETWORK 1	101, 102
NETWORK 2	103, 104
ETC.	