

EAMS060 ELECTRONIC AIR MEASURING STATION WITH CLASS 1A LEAKAGE RATED DAMPER

APPLICATION

Ruskin model EAMS060 combines the precise measurement of the AMCA certified EAMS series air measuring station, with Ruskin's ultra low-leak, class 1A rated control damper, the CD60. The complete unit is factory assembled and calibrated to provide effective setpoint monitoring down to 100 FPM (0.51 m/s). The EAMS060 meets leakage requirements of the International Energy Conservation code. A high performance heated mass flow sensor positioned behind the air scoop manifold inside the sensor chase protects it from water carryover, making this a perfect application for outdoor air measuring applications. The unit comes standard with an application specific control panel that provides a 0-10V output, proportional to the flow.

STANDARD CONSTRUCTION

FRAME, Air Measuring Station

12" (305) deep double flanged 16 (1.6) gauge galvanized steel.

FRAME, Damper

6" X 1" (152 x 25) 6063T6 extruded aluminum T-Flange.

BLADES

6" (152) wide, galvanized steel, one piece airfoil shaped, double skin. Parallel blade standard, opposed blade optional.

AXLES

1/2" (13) plated steel hex.

BEARINGS

Stainless steel sleeve type.

SEALS

Blade: Ruskiprene.

Jamb: 300 series stainless compression type.

LINKAGE

Plated steel, concealed in frame.

AIR SCOOP MANIFOLD

3/4" (19) anodized aluminum pipe with duct averaging ports.

SENSOR

Electronic heated mass flow sensor.

CONTROLLER

Application specific set points factory calibrated.

Program logic & calibration in nonvolatile EPROM.

ACCURACY

3% over measuring range.

POWER REQUIREMENTS

24 VAC +/- 15%, 10VA, 50/60 Hz to terminate at control panel terminal strip.

INPUT SIGNAL

1-5V w/o 250 Ω resistor (or BACnet).

OUTPUT SIGNAL

0-10V calibrated output signal (or BACnet).

VELOCITY REQUIREMENTS

Product Range - 100 to 2000 FPM (0.51 m/s to 10.1 m/s)
(Measured through face area)

OPERATING TEMPERATURE

-20°F to 120°F (-29°C to 50°C).

MINIMUM SIZE

Single 12"w x 12"h x 18"d (305 x 305 x 457).

MAXIMUM SIZE

Single section - 18 sq. ft. (1.67m²).

Multiple section assembly - unlimited. Consult factory for special considerations.

Notes:

1. Values shown in () are millimeters unless otherwise indicated.
2. Refer to installation manual for additional details.
3. Units are furnished actual size ordered and dimensioned to the inside of the flanges.

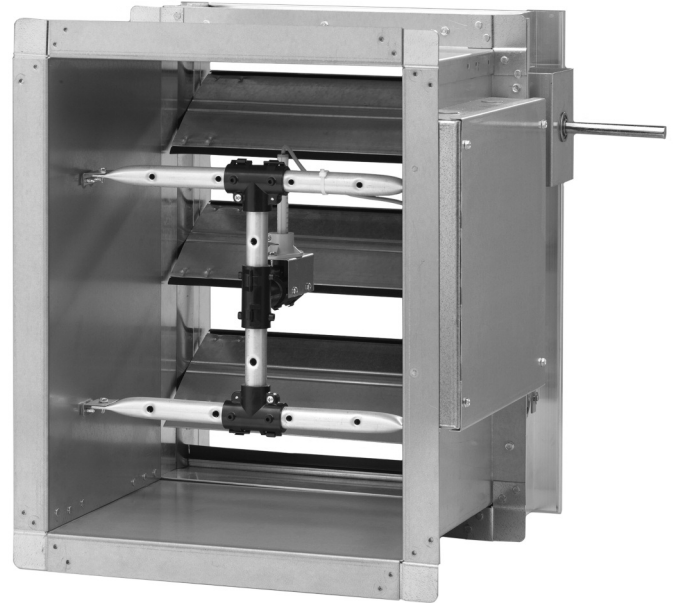

FEATURES

- Factory mounted 24 volt modulating actuator(s)
- Low-leak CD60 Damper
- Factory mounted and commissioned controls
- Electronic heated mass flow sensor
- Factory calibrated controller in nonvolatile EPROM
- BACnet compatible
- Single point 24 volt power connection
- Temperature and altitude compensated

Ruskin EAMS060 helps satisfy the requirements for minimum outside air as required by the following.

- ASHRAE 62.1, 90.1 and 189.1.
- California Title 24
- International Mechanical Code (IMC)
- International Energy Conservation Code (IECC)

VARIATIONS

The EAMS060 is available with several options to fit your specific application.

- 12" x 12" x 6" (305 x 305 x 152) NEMA 1 control enclosure. Controller, 120/24 VAC transformer and terminal strip mounted and shipped with EAMS060.
- Opposed damper blade action
- Silicone damper blade seals
- Stainless steel linkage
- Stainless steel jackshaft
- 120 volt primary/24 volt secondary power transformer shipped loose

PERFORMANCE DATA

TEST RUN	TEST SET UP FIG 1							TEST SET UP FIG 2						
	Reference Volume CFM		Reference Velocity FPM		Indicated Volume CFM		% Deviation Average = .73	Reference Volume CFM		Reference Velocity FPM		Indicated Volume CFM		% Deviation Average = .335
	CFM	l/s	FPM	m/s	CFM	l/s		CFM	l/s	FPM	m/s	CFM	l/s	
AIR PERFORMANCE SIZE 12" x 12" (305mm x 305mm)														
1	202	95	202	1.0	206	97	2.15	199	94	199	1.0	202	95	1.695
2	287	135	287	1.5	277	131	-3.46	287	135	287	1.5	280	132	-2.344
3	388	183	388	2.0	390	184	0.42	388	183	388	2.0	382	180	-1.626
4	457	216	457	2.3	463	219	1.29	475	224	475	2.4	487	230	2.547
5	964	455	964	4.9	971	458	0.68	968	457	968	4.9	965	455	-0.292
6	1,459	689	1,459	7.4	1,445	682	-0.94	1,445	682	1,445	7.3	1,435	677	-0.674
7	2,056	970	2,056	10.4	2,075	979	0.94	2,053	989	2,053	10.4	2,060	972	0.340
8	2,574	1,215	2,574	13.1	2,573	1,214	-0.03	2,582	1,219	2,582	13.1	2,573	1,214	-0.355
AIR PERFORMANCE SIZE 36" x 36" (914mm x 914mm)														
1	210	99	23	0.1	224	106	6.819	645	304	72	0.4	672	317	4.126
2	646	305	72	0.4	637	301	-1.332	726	343	81	0.4	765	361	5.394
3	636	300	71	0.4	670	316	5.268	1,296	612	144	0.7	1,324	625	2.192
4	1,264	597	140	0.7	1,284	606	1.614	2,546	1,202	283	1.4	2,476	1,169	-2.749
5	2,548	1,203	283	1.4	2,555	1,206	0.284	3,414	1,611	379	1.9	3,349	1,581	-1.915
6	3,271	1,544	363	1.8	3,341	1,577	2.148	3,482	1,643	387	2.0	3,436	1,622	-1.328
7	4,469	2,109	497	2.5	4,343	2,050	-2.817	4,194	1,979	466	2.4	4,165	1,966	-0.695
8	4,511	2,129	501	2.5	4,522	2,134	0.247	4,459	2,104	495	2.5	4,518	2,132	1.317
9	9,594	4,528	1,066	5.4	9,681	4,569	0.903	9,395	4,434	1,044	5.3	9,526	4,496	1.389
10	12,723	6,005	1,414	7.2	12,871	6,074	1.160	12,554	5,925	1,395	7.1	12,613	5,953	0.467
11	18,462	8,713	2,051	10.4	18,215	8,597	-1.336	18,519	8,740	2,058	10.5	18,293	8,633	-1.217
12	23,227	10,962	2,581	13.1	23,347	11,019	0.516	23,326	11,009	2,592	13.2	24,428	11,529	0.436

Pressure Drop Through Manifold						
Test Run	Pressure Drop		Volume CFM		Velocity	
	In WG	Pa	CFM	l/s	FPM	m/s
Airflow Resistance Size 12" x 12" (305mm x 305mm)						
1	0.158	39	2,584	1,220	2,584	13.1
2	0.103	26	2,065	975	2,065	10.5
3	0.052	13	1,465	691	1,465	7.4
4	0.027	7	968	457	968	4.9
5	0.005	1	460	217	460	2.3
Airflow Resistance Size 36" x 36" (914mm x 914mm)						
1	0.041	10	23,247	10,971	2,583	13.1
2	0.026	6	18,477	8,720	2,053	10.4
3	0.016	4	12,735	6,010	1,415	7.2
4	0.010	2	9,603	4,532	1,067	5.4
5	0.005	1	4,509	2,128	501	2.5

PRESSURE DROP THROUGH DAMPER VELOCITY VS. PRESSURE DROP

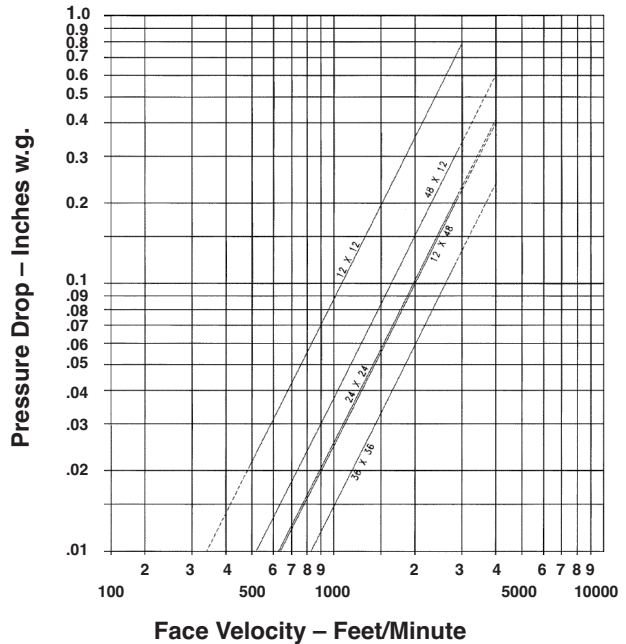

Accuracy based on tests and procedures performed in accordance with AMCA test standards. Two EAMS air measurement stations were tested to AMCA test set up figures 1 and 2 with results as shown.

The reference velocity is the flow indicated on the AMCA registered wind tunnel, expressed in CFM (l/s) and FPM (m/s). The indicated volume is calculated from the controller output. The 0-10V output is proportional to flow.

While the EAMS unit is AMCA certified, the rating does not apply to the EAMS060 combination model.

Pressure drop through the air scoop manifold must be added to the pressure drop shown on the damper pressure drop chart at the right.

Example:

Pressure drop through a 36" x 36" (914 x 914) EAMS060 at 1,000 FPM (5.1 m/s) is determined as follows.

.010" + .015" = .025" W.G. at 1,000 FPM (2.49 + 3.73 Pa = 6.22 Pa at 5.1 m/s).

WIRING SCHEMATIC

Ruskin's EAMS060 is supplied and calibrated with a dedicated controller. Attempting to use another controller (not supplied by Ruskin) or tampering with the wiring under the control panel cover plate will void the warranty and could render the EAMS060 unit ineffective. Please

contact the factory prior to performing any service on the factory wiring.

For more detailed information refer to the online installation and maintenance manual at www.ruskin.com.

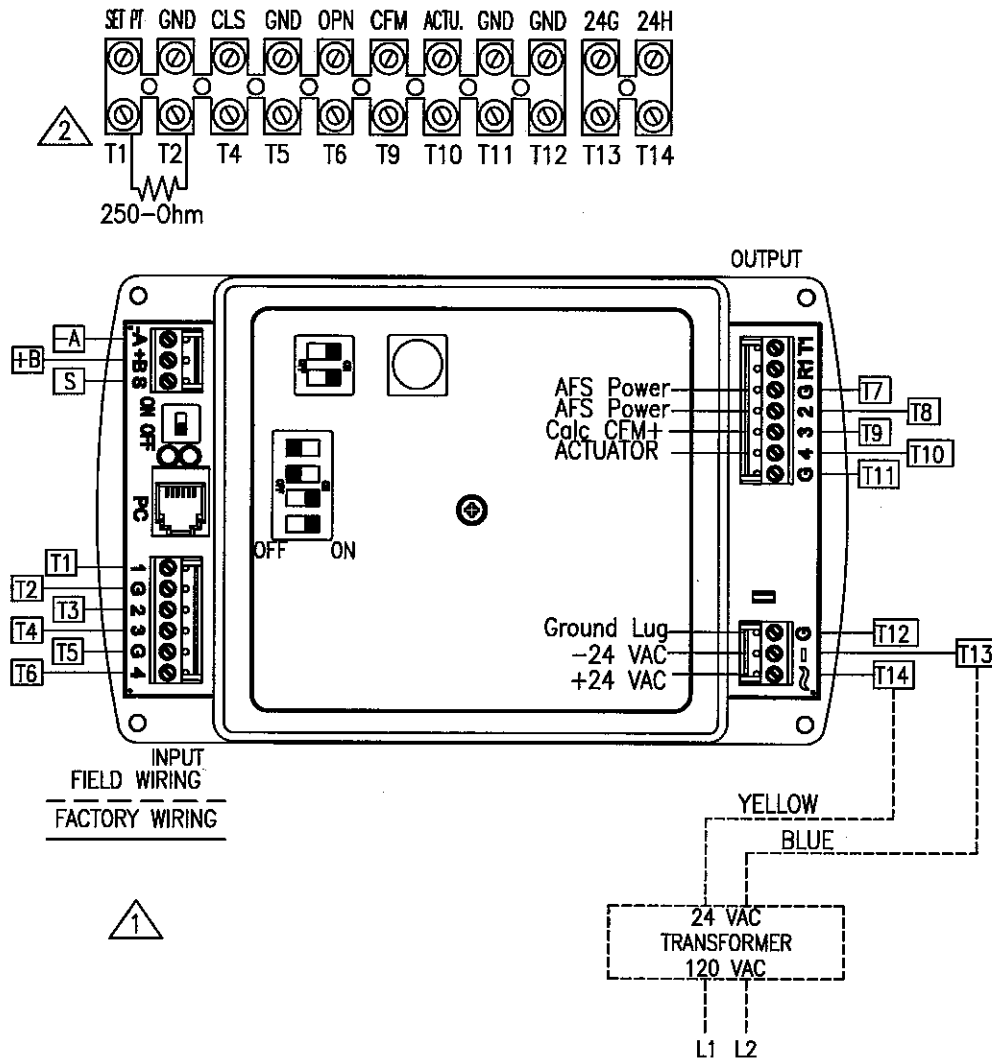

FIELD WIRING TO TERMINAL STRIP EAMS W/ DAMPER				
INPUTS				
TERMINAL STRIP	DESCRIPTION	SIGNAL TYPE	DEVICE	FIELD WIRING
T1	CFM SET POINT	1-5 VDC	1	FROM BAS
T2	GND		GND	FROM BAS
T3	AIR FLOW SENSOR	0-5 VDC	2	AFS GREEN
T4	OVERRIDE DMPCLS	N.C.	3	FROM BAS
T5	GND		GND	FROM BAS
T6	OVERRIDE DMPOPN	N.O.	4	FROM BAS
OUTPUTS				
TERMINAL STRIP	DESCRIPTION	SIGNAL TYPE	DEVICE	FIELD WIRING
T7	AFS POWER	GND	GND	AFS BROWN
T8	AFS POWER	+12 VDC	2	AFS WHITE
T9	CALC CFM	0-10 VDC	3	TO BAS
T11			GND	TO BAS

CONTROLLER TERMINAL STRIP		
TERMINAL	WIRE COLOR	CONTROLLER
T3	GREEN	I2
T7	BROWN	GND
T8	WHITE	O2
AIR FLOW SENSOR		

DEVICE		POWER	BELIMO ACTUATOR		
T10	SIGNAL	0-10 VDC			
T13	-24 VAC	BLACK WIRE (1)	-		ACTUATOR 24G
T14	+24 VAC	RED WIRE (2)	~		ACTUATOR 24H
DEVICE		POWER	HONEYWELL ACTUATOR		
T10	SIGNAL	0-10 VDC			
T13	-24 VAC	BLACK WIRE (2)	-		24V COMMON
T14	+24 VAC	RED WIRE (1)	~		24V HOT

DIMENSIONAL DETAILS

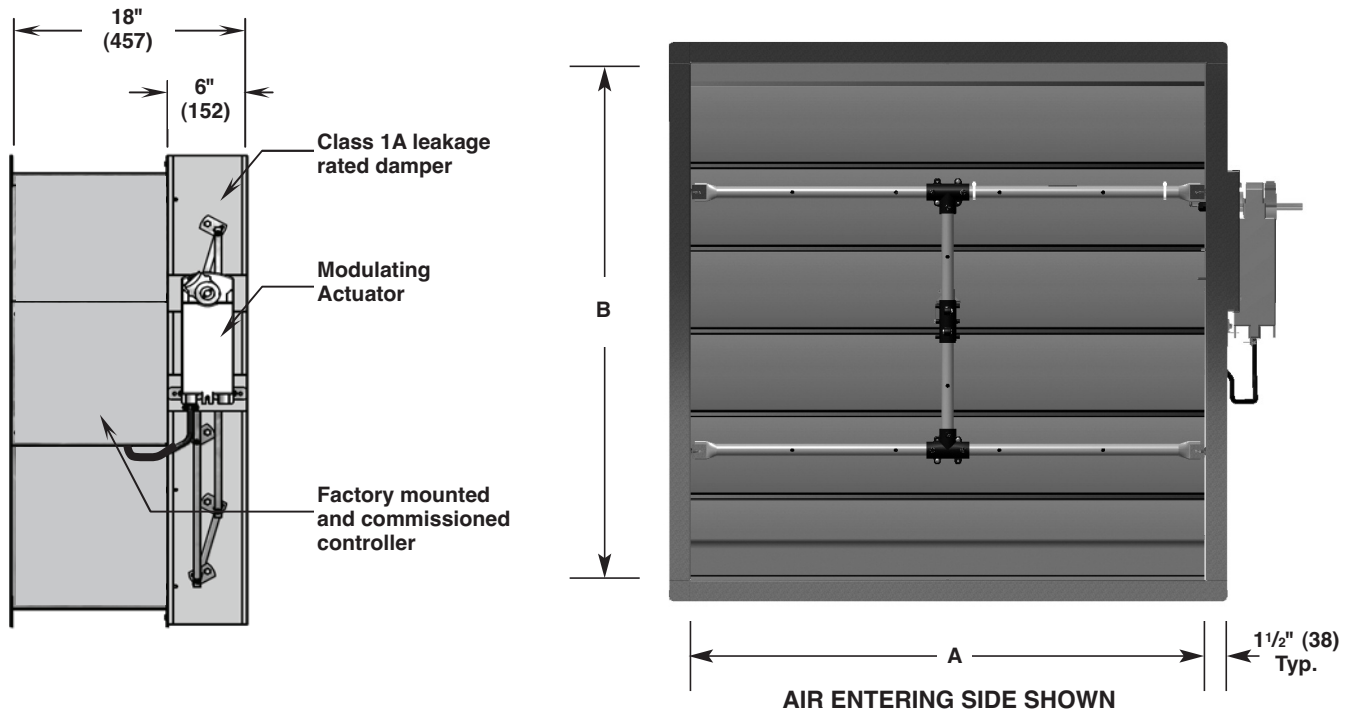

SUGGESTED SPECIFICATION

Furnish and install an electronic mass airflow measuring station with integral damper and controls. Assembly shall be capable of measuring a range from 100 to 2,000 FPM (0.51 m/s to 10.1 m/s) at a temperature range of -20°F to 120°F (-29°C to 50°C). Air measuring assembly shall include a leakage class 1A control damper with double skin airfoil shaped blades. Blades shall be equivalent to 12 gauge (2.7) double v-groove Industrial galvanized blade shape and shall not exceed 60" (1524) in length. Damper bearings shall be stainless steel sleeve type. Damper frame shall be 6063T6 extruded aluminum T-Flange. Damper shall be supplied with stainless steel compression jamb seals and Ruskiprene blade edge seals that are mechanically fastened. The air measuring station shall consist of a 1.50" x 12" x 1.50" (38 x 305 x 38), 16 gauge (1.6) galvanized steel air scoop manifold frame, .75" (19) air scoop manifold with duct averaging ports, sensor chase, Electronic heated mass flow sensor(s) and a factory programmed control module. All sensors in the assembly shall be installed in a protective sensor chase behind an air scoop manifold to prevent water penetration and large airborne particulate from settling on the sensing element. The assembly shall yield a 3% average measuring

accuracy over the entire specified measuring range. All performance and accuracy ratings shall be supported by data collected from tests performed on an AMCA registered wind tunnel. A factory furnished and calibrated controller shall be programmed, in non-volatile EPROM, with the job specific flow range. Each unit shall be tunnel tested to ensure accuracy of the final assembly prior to shipping to the job site. The manufacturer shall furnish a data chart that is a representation of the final test. The test data chart shall show, as a minimum, output signal and corresponding flow. The controller shall report a 0-10V linear output that is proportional to the flow and shall be altitude and temperature compensating. Controller shall have a field selectable BACnet communication feature to facilitate digital communications when required. Installing contractor shall coordinate proper sizing and placement of the air measuring station with a qualified manufacturer's representative prior to installation. Complete assembly shall be constructed, programmed, wired and calibrated in an ISO 9001 certified facility. Air Measuring Stations shall be, in all respects, equivalent to Ruskin Model EAMS060.

RUSKIN®

3900 Dr. Greaves Rd.
Kansas City, MO 64030
(816) 761-7476
FAX (816) 765-8955
www.ruskin.com