



Technical Data		NFBUP RUS
Power supply		24...240 VAC -20% / +10%, 50/60 Hz 24...125 VDC ±10%
Power consumption	running	6 W
	holding	2.5 W
Transformer sizing		6 VA @ 24 VAC (class 2 power source) 6.5 VA @ 120 VAC 9.5 VA @ 240 VAC
Electrical connection		3 ft, 18 GA appliance cable, 1/2" conduit connector
Overload protection		electronic throughout 0 to 95° rotation
Control		on/off
Torque		90 in-lb [10 Nm] minimum
Direction of rotation	spring	reversible with CW/CCW mounting
Mechanical angle of rotation		95° (adjustable with mechanical end stop, 35° to 95°)
Running time	motor	< 75 seconds
	spring	20 seconds @ -4°F to 122°F [-20°C to 50°C]; < 60 seconds @ -22°F [-30°C]
Position indication		visual indicator, 0° to 95° (0° is full spring return position)
Manual override		5 mm hex crank (3/16" Allen), supplied
Humidity		max. 95% RH non-condensing
Ambient temperature		-22°F to 122°F [-30°C to 50°C]
Storage temperature		-40°F to 176°F [-40°C to 80°C]
Housing		Nema 2, IP54, Enclosure Type2
Housing material		zinc coated metal and plastic casing
Agency listings †		cULus acc. to UL60730-1A/-2-14, CAN/CSA E60730-1:02, CE acc. to 2004/108/EC & 2006/95/EC
Noise level		<50dB(A) motor @ 75 seconds ≤62dB(A) spring return
Servicing		maintenance free
Quality standard		ISO 9001
Weight		4.15 lbs (1.9 kg), 4.4 lbs (2.0 kg) with switches

† Rated Impulse Voltage 4kV, Type of action 1.AA (1.AA.B for -S version), Control Pollution Degree 3.

Torque min. 90 in-lb, for control of air dampers

Application

For On/Off, fail-safe control of dampers in HVAC systems. Actuator sizing should be done in accordance with the damper manufacturer's specifications. Control is On/Off from an auxiliary contact, or a manual switch.

The actuator is mounted directly to a damper shaft up to 1.05" in diameter by means of its universal clamp. A crank arm and several mounting brackets are available for applications where the actuator cannot be direct coupled to the damper shaft.

Operation

The NFB RUS series actuators provide true spring return operation for reliable fail-safe application and positive close off on air tight dampers. The spring return system provides constant torque to the damper with, and without, power applied to the actuator.

The NFB RUS series provides 95° of rotation and is provided with a graduated position indicator showing 0° to 95°.

The actuator may be stalled anywhere in its normal rotation without the need of mechanical end switches.

The NFBUP RUS actuator is shipped at +5° (5° from full fail-safe) to provide automatic compression against damper gaskets for tight shut-off.

Dimensions (Inches [mm])

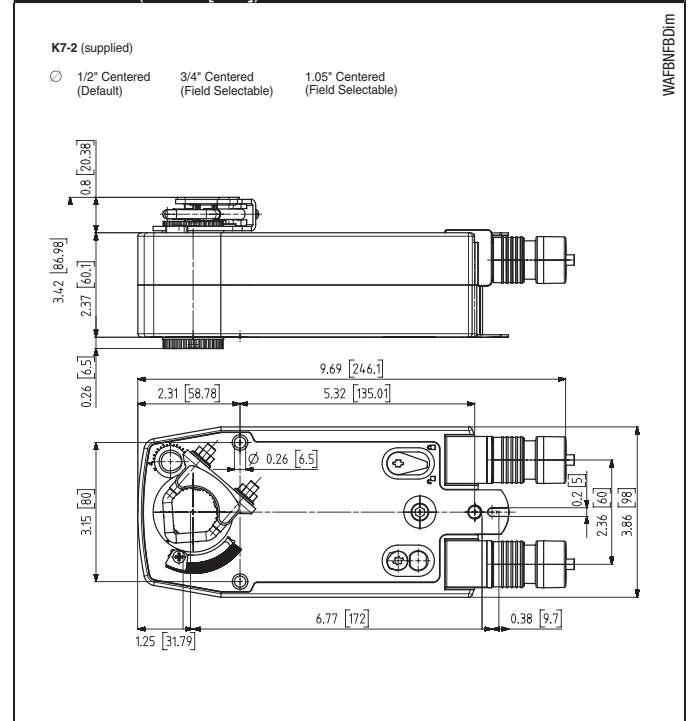

Accessories

AV 8-25	Shaft extension
IND-AFB	Damper position indicator
K7-2	Universal clamp for up to 1.05" dia jackshafts
KH-AFB	Crank arm
TF-CC US	Conduit fitting
Tool-06	8mm and 10 mm wrench
ZG-100	Universal mounting bracket
ZG-101	Universal mounting bracket
ZG-118	Mounting bracket for Barber Colman® MA 3../4..., Honeywell® Mod III or IV or Johnson® Series 100 replacement or new crank arm type installations
ZG-AFB	Crank arm adaptor kit
ZG-AFB118	Crank arm adaptor kit
ZS-100	Weather shield (metal)
ZS-150	Weather shield (polycarbonate)
ZS-260	Explosion-proof housing
ZS-300	NEMA 4X housing

Note: When using NFBUP RUS actuators, only use accessories listed on this page.
For actuator wiring information and diagrams, refer to Belimo Wiring Guide.

Typical Specification

On/Off spring return damper actuators shall be direct coupled type which require no crank arm and linkage and be capable of direct mounting to a jackshaft up to a 1.05" diameter. The actuators must be designed so that they may be used for either clockwise or counterclockwise fail-safe operation. Actuators shall be protected from overload at all angles of rotation. If required, two SPDT auxiliary switch shall be provided having the capability of one being adjustable. Actuators with auxiliary switches must be constructed to meet the requirements for Double Insulation so an electrical ground is not required to meet agency listings. Actuators shall be cULus Approved and have a 5 year warranty, and be manufactured under ISO 9001 International Quality Control Standards. Actuators shall be as manufactured by Belimo.

Wiring Diagrams

✂ INSTALLATION NOTES

- 1 Provide overload protection and disconnect as required.
- 2 **CAUTION Equipment Damage!**
Actuators may be connected in parallel.
Power consumption and input impedance must be observed.
- 3 No ground connection is required.

📄 APPLICATION NOTES

- ◆ Meets cULus requirements without the need of an electrical ground connection.

⚠ WARNING Live Electrical Components!

During installation, testing, servicing and troubleshooting of this product, it may be necessary to work with live electrical components. Have a qualified licensed electrician or other individual who has been properly trained in handling live electrical components perform these tasks. Failure to follow all electrical safety precautions when exposed to live electrical components could result in death or serious injury.

