

## INSTALLATION INSTRUCTIONS

### FSDR25 and FSDR25SS COMBINATION FIRE AND SMOKE DAMPER

1½ HOUR UL555 RATED UL555S LEAKAGE CLASS 1 RATED

#### APPLICATION

The FSDR25(SS) are "true" round, single blade, combination fire/smoke dampers for openings in walls, partitions or masonry floors with ratings of less than 3 hours. They are designed for use with round duct and the openings may be square or round. The standard installation is with the leading edge of the closed blades within the wall or masonry floor. Installation may be obtained with the "CINCH" plate on one side for metal stud or masonry walls and "CINCH" plate both sides for wood stud wall and masonry floors.

#### MOUNTING

Vertical or horizontal.

#### MINIMUM SIZE

6" (152) diameter.

#### MAXIMUM UL CLASSIFIED SIZE

24" (610) diameter.

#### INSTALLATION SUPPLEMENTS

Refer to the appropriate Ruskin installation instructions supplements for additional information or special requirements:

- Optional Sealant of Dampers in Fire Rated Wall or Floor Openings
- TS150 FireStat for "Reopenable" Combination Fire and Smoke Dampers
- SP100 Switch Package
- EFL Electric Resettable "Fuse" Link
- EFL/SP100 Electric Resettable "Fuse" Link and Switch Package
- PFL Pneumatic Fuse Link

Dimensions shown in parentheses ( ) indicate millimeters.

## RETAINING "CINCH" PLATES

#### RETAINING "CINCH" PLATE

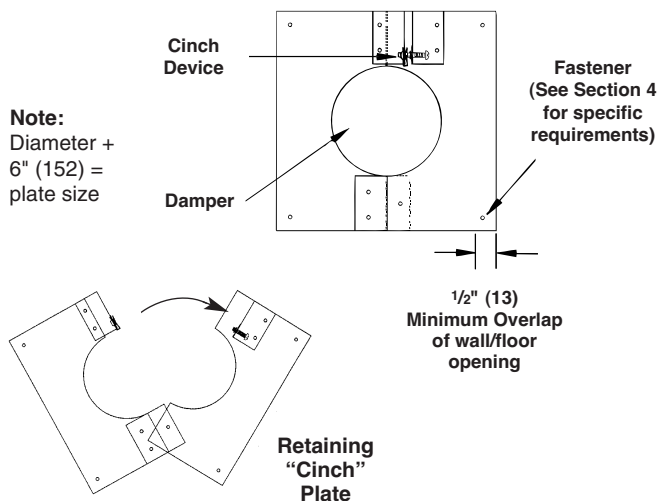

SEE COMPLETE MARKING  
ON PRODUCT

California State Fire Marshal Listing No. FSDR25 - 3235-0245:0128

NYC Department Of Building MEA 252-05-E

II-FSDR25-514/Replaces II-FSDR25-813

ALL STATED SPECIFICATIONS ARE SUBJECT TO CHANGE WITHOUT NOTICE OR OBLIGATION.

© Ruskin 2014

#### 1. Opening Clearance

A **square** opening in wood or metal stud walls or masonry walls and floors shall be a minimum of 1" (25) and a maximum of 2½" (64) larger than the damper diameter. A **round** opening in masonry walls or floors shall be a minimum of 1" (25) and a maximum of 2½" (64) larger than the damper diameter.

**THE RETAINING "CINCH" PLATE MUST OVERLAP THE OPENING A MINIMUM OF ½" (13).**

#### 2. Damper Sleeve

The sleeve is integral to the damper and shall be of equal to or heavier than the gage of the duct as described in NFPA90A and as defined by the appropriate SMACNA duct construction standard.

#### 3. Damper Orientation

The leading edge of the blade in the closed position must be within the plane of the wall. Vertical installation is illustrated and horizontal is similar (see General Installation). The damper may be installed with up to a 30 degree variance of the axle being horizontal (see Blade Orientation section).

#### 4. Retaining "Cinch" Plates

##### DO NOT PLACE CINCH PLATES IN GROOVE

The retaining "cinch" plates are designed to grab and hold the sleeve while mounting flush against the wall or floor retaining the damper securely in the opening. The plates must overlap the opening a minimum of ½" (13) (see "Cinch" Plate section).

**The "Cinch" plates are fastened to the wall or floor according to the following:**

- Masonry Wall – "Cinch" plate required on only one side of the wall fastened to the wall with a minimum of 1¼" (32) #10 masonry screw.
- Masonry Floor – "Cinch" plate required on both the top and bottom of the floor fastened to the floor with a minimum of 1¼" (32) #10 masonry screw.
- Metal Stud Wall – "Cinch" plate required on only one side of the wall fastened to the wall by engaging the metal stud a minimum of ½" (13) with a #10 screw.
- Wood Stud Wall – "Cinch" plate required on both sides of the wall fastened to the wall by engaging the wood stud a minimum of 1½" (38) with a #10 screw.

#### 5. Duct/Sleeve Connections

Round break-away connections must be used. Either a 4" (102) wide drawband or #10 sheet metal screws spaced equally around the circumference of the ducts as follows:

- Duct diameters 22" (559) and smaller – 3 screws.
- Duct diameters over 22" (559) to 24" (610) – 5 screws.

**Note:** When optional sealing of these joints is desired, the following sealants may be applied in accordance with the sealant manufacturer's instructions: Hardcast, Inc. - Iron Grip 601, Precision - PA2084T, ECO Duct Seal 44-52 or Design Polymeric - DP 1010.

#### 6. Actuator Connections

Electric and pneumatic actuators are to be connected in accordance with wiring and piping diagrams developed in compliance with applicable codes, ordinances and regulations.

#### 7. Installation and Maintenance

Do not compress or stretch the damper frame into the duct or opening. Lift or handle the damper using sleeve or frame. Do not lift damper using blade or actuators. Each fire/smoke damper should be maintained, cycled and tested at intervals not less than every six months and in accordance with the latest editions of NFPA 90A, 92A, UL864, local codes and in accordance with actuator manufacturer recommendations. Care should be exercised to ensure that such tests are performed safely and do not cause system damage.

## GENERAL INSTALLATION

### In Rated Masonry Walls or Floor/Ceiling Assemblies of Less than 3 Hour, with Square or Round Openings

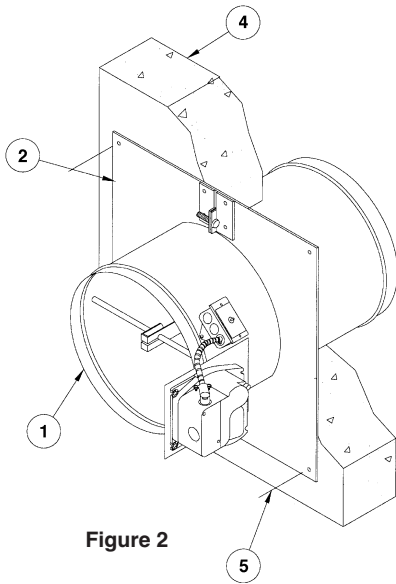

Figure 2

#### ITEM DESCRIPTION

1. FSDR25 Round Fire/Smoke Damper
2. Retaining "Cinch" Plate, 20 ga. steel
3. Duct
4. Masonry Wall or Floor
5. #10 Concrete Anchor, (min 1 1/4" (31) long)
6. Duct/Sleeve Connection
7. Opening Clearance

**Note: Masonry walls only require a "cinch" plate on one side of the wall. Masonry floors require a "cinch" plate on both top and bottom side of the floor.**

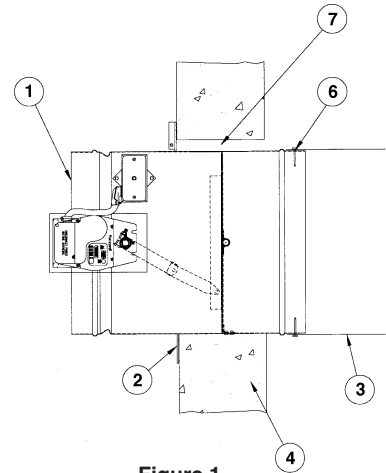
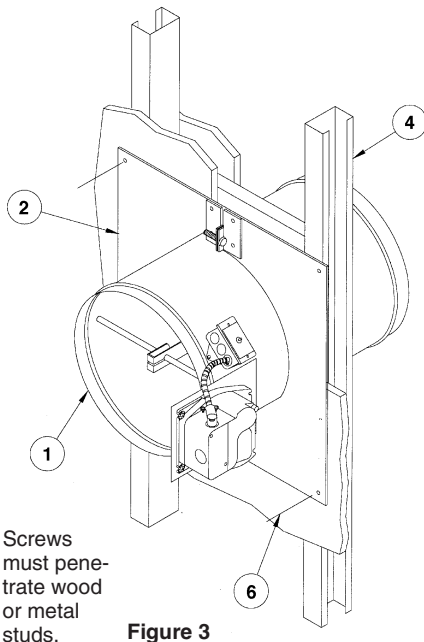

Figure 1

### In Rated Metal or Wood Stud Framed Drywall Partitions of Less Than 3 Hour with Square Openings



Screws must penetrate wood or metal studs.

Figure 3

#### ITEM DESCRIPTION

1. FSDR25 Round Fire/Smoke Damper
2. Retaining "Cinch" Plate, 20 ga. steel
3. Duct
4. Metal Stud Wall (plate required on only one side)
5. Wood Stud Wall (plate required on both sides)
6. #10 Sheet Metal Screw (refer to section 4 for fastener requirements).
7. Duct/Sleeve Connection
8. Opening Clearance

**Note: Metal stud walls require retaining "cinch" plates on only one side of the wall. Wood stud walls require retaining "cinch" plates on both sides of the wall.**

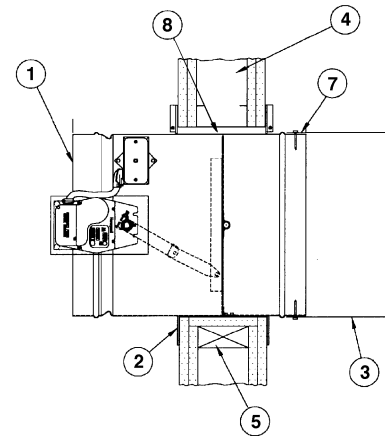
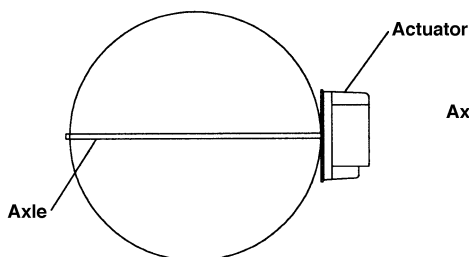
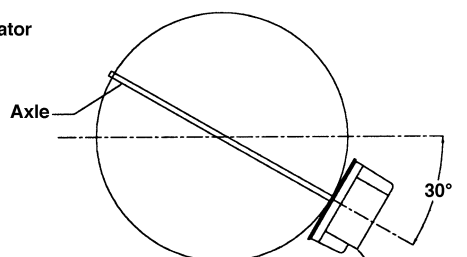

Figure 4

## BLADE ORIENTATION



NORMAL



30° OFF HORIZONTAL  
(Maximum)

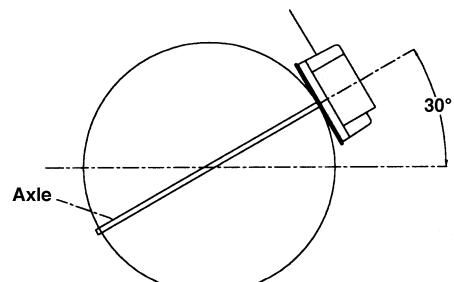

30° OFF HORIZONTAL  
(Maximum)

## RECOMMENDED FRAMING FOR OPENINGS IN WOOD AND METAL STUD WALLS

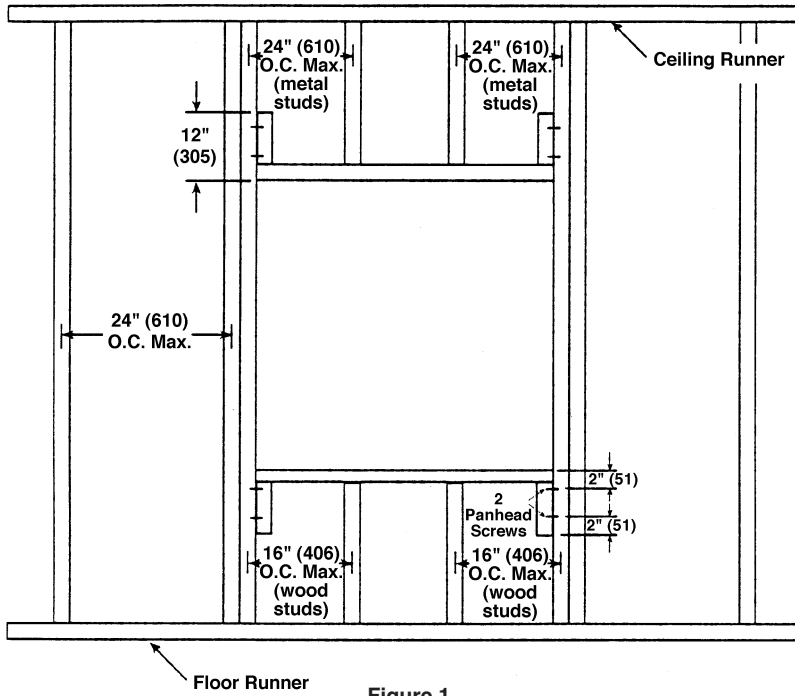

Figure 1

### INSTRUCTIONS

1. Frame wall openings as shown.
2. Double vertical studs are not required for openings 36" w x 36" h (914 x 914) or smaller.
3. All construction and fasteners must meet the requirements of the appropriate wall design and/or local codes.
4. Consult the authority having jurisdiction for other acceptable framing methods.

### NOTE:

The Metal Stud Construction and Wood Stud Construction figures at the bottom of the page depict mounting plates installed on both sides of the partition. A single cinch plate may be sufficient. Refer to the instructions for single angle installation requirements.

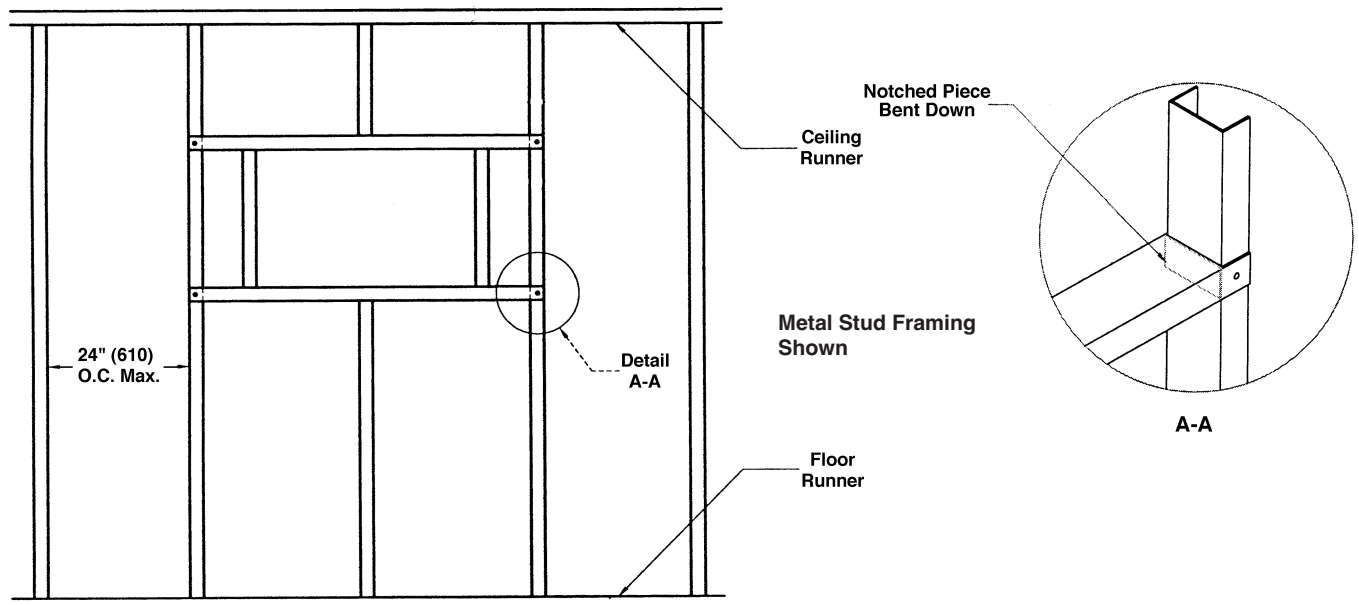
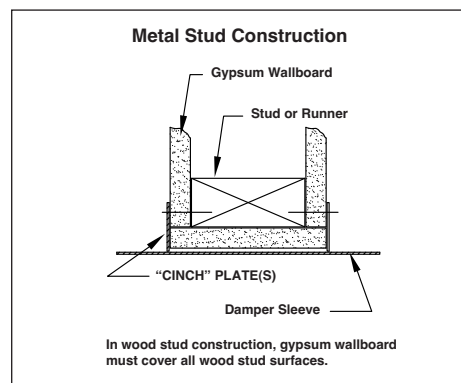
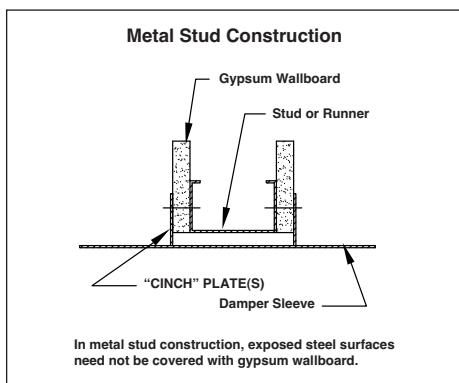

Figure 2



***RUSKIN***<sup>®</sup>

3900 Dr. Greaves Rd.  
Kansas City, MO 64030  
(816) 761-7476  
FAX (816) 765-8955  
[www.ruskin.com](http://www.ruskin.com)