



INSTALLATION INSTRUCTIONS

SMOKE DAMPERS

MODELS SD35, SD36, SD37, SD50, SD60(M), SD60-2, SD60V(M), SD35SS, SD36SS, SD37SS, SD50V(M), SDRS25(M), SDRS25SS(M) and TFD30 UL555S LEAKAGE RATED CLASS 1, 2, AND 3

APPLICATION

Smoke dampers are designed to be vertically or horizontally installed, in accordance with NFPA90A, at or adjacent to the point where the duct passes through the smoke barrier. In no case shall the damper be installed with an outlet or inlet between the smoke barrier and the damper or more than 24" (610) from the smoke barrier. Smoke dampers are operated with electric or pneumatic actuators that either power open (spring closed) or power closed (spring open).

SD35 and SD36 MAXIMUM UL CLASSIFIED SIZE

- OPPOSED AND PARALLEL BLADE

Single Section (only) Vertical or Horizontal Installation - 36"w x 72"h (914 x 1829)

Multiple Section Assembly Vertical or Horizontal Installation - 144"w x 96"h (3658 x 2438) or 288"w x 48"h (7315 x 1219) or 72"w x 192"h (1829 x 4877)

SD37, SD60, SD60-2, and SD50 MAXIMUM UL CLASSIFIED SIZE

- OPPOSED AND PARALLEL BLADE

Single Section (only) Vertical or Horizontal Installation - 48"w x 72"h (1219 x 1829)

Multiple Section Assembly Vertical or Horizontal Installation - 144"w x 96"h (3658 x 2438) or 288"w x 48"h (7315 x 1219) or 72"w x 192"h (1829 x 4877)

SD50V(M) MAXIMUM UL CLASSIFIED SIZES

- PB or OB BLADES

Single Section (only) Vertical or Horizontal Installation - 48"w x 36"h (1219 x 914)

Multiple Section Vertical or Horizontal Installation - 384"w x 36"h (9830 x 914) or 192"w x 72"h (4915 x 1843) or 48"w x 288"h (1219 x 7373) or 96" x 144" (2457 x 3657)

SD35SS and SD36SS MAXIMUM UL CLASSIFIED SIZE

- OPPOSED BLADES

Single Section (only) Vertical or Horizontal Installation - 36"w x 48"h (914 x 1219)

Multiple Section Assembly Vertical or Horizontal Installation - 144"w x 96"h (3658 x 2438) or 288"w x 48"h (7315 x 1219) or 72"w x 192"h (1829 x 4877)

SD37SS MAXIMUM UL CLASSIFIED SIZE

- OPPOSED BLADES

Single Section (only) Vertical or Horizontal Installation - 24"w x 36"h (610 x 914)

Multiple Section Assembly Vertical or Horizontal Installation - 96"w x 64"h (2438 x 1625) or 192"w x 32"h (4877 x 813) or 48"w x 128"h (1219 x 3251)

SD60V(M) MAXIMUM UL CLASSIFIED SIZES

- OPPOSED BLADES

Single Section Vertical or Horizontal Installation - 48"w x 36"h (1219 x 914)

Multiple Section Vertical or Horizontal Installation - 384"w x 36"h (9830 x 914) or 192"w x 72"h (4915 x 1843) or 48"w x 288"h (1219 x 7373) or 96" x 144" (2457 x 3657)

SDRS25(M) and SDRS25SS(M) MAXIMUM UL CLASSIFIED SIZES -

Single Section (only) Vertical or Horizontal Installation - 24" (610) diameter.

TFD30 MAXIMUM UL CLASSIFIED SIZE -

OPPOSED BLADES

Single Section (only) Vertical or Horizontal Installation - 39.37"w x 39.37"h (1000 x 1000)

Dimensions shown in parentheses () indicate millimeters.

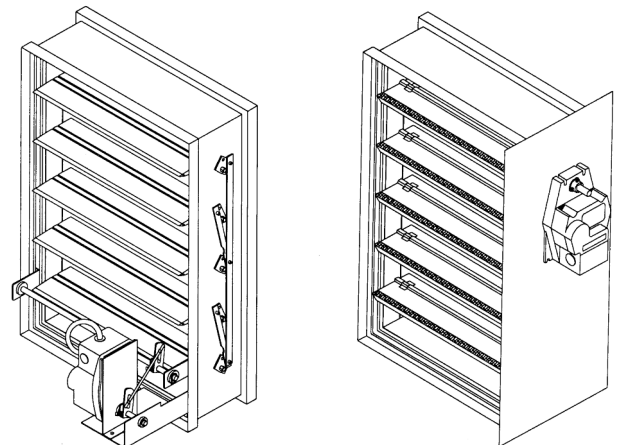

SEE COMPLETE MARKING ON PRODUCT

1. Location of Damper in Ductwork

Smoke Dampers must be placed in the ductwork so the closed blades are within 24" (610) of the smoke barrier and before any duct inlets or outlets (access doors not included).

2. Fasteners and Multiple Section Assembly

When joining multiple damper assemblies or fastening the damper to the ductwork, dampers shall be fastened with 1/4"-20 (M6) bolts, #10 (M5) screws, 1/2" (13) long welds or 3/16" tubular steel rivets. Fasteners shall be spaced a maximum of 12" (305) center to center with a minimum of two fasteners per side.

3. Sealing the Installation

Smoke dampers must be sealed between the damper frames (when joining multiple sections to form an assembly) and between the damper frame and ductwork. Seal the above joints using Dow-Corning Silastic 732 RTV or GE RTV 108. The sealant shall be pressed in place to dispel any air and shall be applied to one side of the damper's face. Use the minimum amount of material to completely seal the joint.

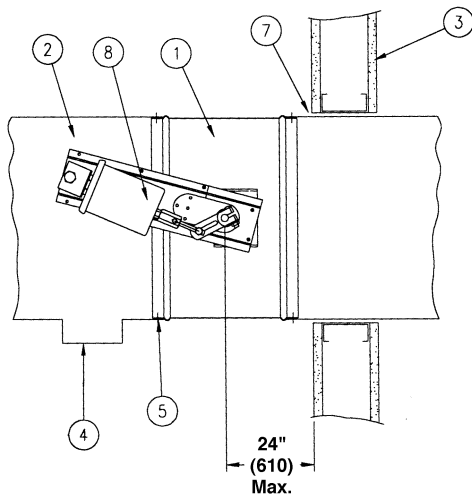

SDRS25 and SDRS25SS Series
Single Blade Round Smoke Damper
Installed within a Duct or Sleeve

4. Actuator Connections

Electric and pneumatic actuators are to be connected in accordance with wiring and piping diagrams developed in compliance with applicable codes, ordinances and regulations. Multiple section or single section dampers utilizing more than one actuator require all actuators to be connected to a single (common) point for simultaneous operation (closure).

5. Installation and Maintenance

To ensure optimum operation and performance, the damper must be installed so it is square and free from racking. Ruskin recommends that each smoke damper be maintained, cycled and tested every six months and in accordance with the latest editions of NFPA90A, 92A, UL864, local codes and in accordance with actuator manufacturer's recommendations. Care should be exercised to ensure that tests are performed safely and do not cause system damage.

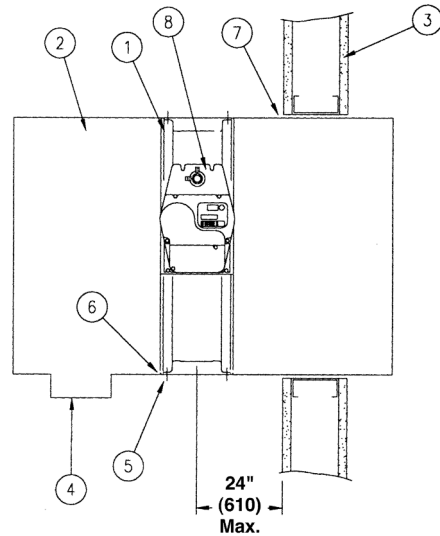

SD35, SD36, SD37, SD50, SD60, SD60-2
SD35SS, SD36SS and SD37SS
Multiple Blade Smoke Damper
Installed within a Duct or Sleeve

ITEM

DESCRIPTION

- | | |
|----|---|
| 1. | Damper |
| 2. | Duct or Sleeve |
| 3. | Smoke Barrier |
| 4. | Duct Outlet |
| 5. | No. 8 (Minimum) Fastener |
| 6. | Caulking Material |
| 7. | Caulking or fire stopping as required by building code. |
| 8. | Operator / Actuator |
| 9. | Flanged Duct or Bulkhead |

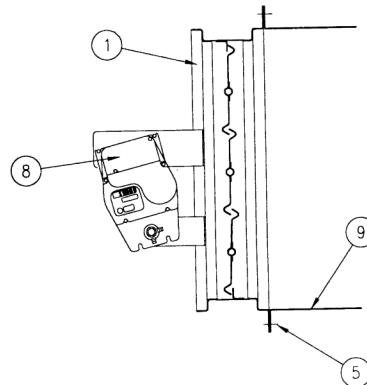

SD35, SD36, SD37, SD50, SD50V(M), SD60,
SD60V(M), SD60-2, SD35SS, SD36SS and SD37SS
Multiple Blade Smoke Damper
Installed within a Flanged Frame or Flanged Sleeve



3900 Dr. Greaves Rd.
Kansas City, MO 64030
(816) 761-7476
FAX (816) 765-8955
www.ruskin.com