

## TED50XT EXTREME TEMPERATURE THERMALLY EFFICIENT INSULATED BLADE DAMPER

### APPLICATION

Ruskin model TED50XT is a low leak, thermally efficient damper with insulated extruded aluminum blades specially designed for reliable performance in extreme temperature conditions. Each blade has a thermal break that is strategically placed between twin blade edge seals. The twin seals create a neutral zone to ensure there is no thermal path. This feature eliminates thermal transfer and reduces potential for condensation. TED50XT satisfies the leakage requirements of the IECC (International Energy Conservation Code).

### STANDARD CONSTRUCTION

#### FRAME

- 5" (127) x 1" (25) x .125 (3) thick 6063T6 high yield aluminum.
- 6" (152) x 1<sup>3</sup>/<sub>8</sub>" (35) x .125 (3) thick 6063T6 high yield aluminum with optional quick connect "T" flange frame.
- 6" (152) x 1" (25) thick 6063T6 high yield aluminum with optional thermal break frame.

#### BLADE(S)

- <sup>5</sup>/<sub>64</sub>" (2) 6063T6 high yield aluminum with opposed blade action and thermal break.

#### AXLES

- <sup>1</sup>/<sub>2</sub>" (13) nominal hexagonal plated steel.

#### BEARINGS

- Dual action polycarbonate internal hex rotating inside an Acetyl Copolymer outer sleeve.

#### BLADE SEALS

- Mechanically fastened extruded bulb silicone.

#### JAMB SEALS

- Combination compression/ribbed extruded silicone.

#### LINKAGE

- Swedgelock™ assembly plated steel concealed out of airstream.

#### OUTPUT SHAFT

- <sup>1</sup>/<sub>2</sub>" (13) dia. x 6" (152) long plated steel shaft single section units.
- <sup>1</sup>/<sub>2</sub>" (13) dia. jackshaft on multi-section assemblies up to 12<sup>1</sup>/<sub>2</sub> ft.<sup>2</sup> (3. 8m<sup>2</sup>).
- 1" (25) dia. jackshaft multi-section assemblies over 12<sup>1</sup>/<sub>2</sub> ft.<sup>2</sup> (3. 8m<sup>2</sup>).

#### PRESSURE

- Up to 8.0" water gage (2 kPa) pressure.

#### VELOCITY

- Up to 4,000 fpm (20.3 m/s).

#### LEAKAGE

- Class 1A at 1" water gage (.25 kPa).
- Class 1 at 4" water gage (1 kPa).

#### TEMPERATURE RANGE

- 70°F to 200°F (-57°C to 93°C) with Silicone seals.

#### MINIMUM SIZE

- Parallel blade unit: 6" x 6" (152 x 152).
- Opposed blade unit: 6" x 11<sup>1</sup>/<sub>2</sub>" (152 x 292).

#### MAXIMUM SIZE

- Single section: 60" x 72" (1524 x 1829) single section.
- Multi-section: multiple factory assembled 48" x 72" (1219 x 1829) sections with unlimited overall dimensions.

#### NOTES:

- Values shown in parentheses ( ) are millimeters unless otherwise indicated.
- Refer to Installation Instructions for additional details.
- Units furnished approximately <sup>1</sup>/<sub>4</sub>" (6mm) smaller than given opening dimensions when standard frame is ordered.
- Units ordered with "T" flange or thermal break frame option are furnished with dimensions I.D. of frame and actual size.



### FEATURES

- 345% Thermal efficiency
- Extrusions with over 30% higher yield stress
- 6063T6 High yield extruded aluminum construction
- Twin blade seals with neutral zone thermal break
- Dual action injection molded bearing and bearing surface frame insert
- Ruskin Swedgelock™ linkage system

### VARIATIONS

Ruskin model TED50XT is available with the following variations at additional cost

- Front or rear flange frame
- Thermal break in frame
- Quick connect "T" flange frame (reduces pressure drop)
- Factory furnished and commissioned actuators
- Insulated frame
- Stainless steel linkage
- Clear anodized finish

# DIMENSIONAL DETAILS

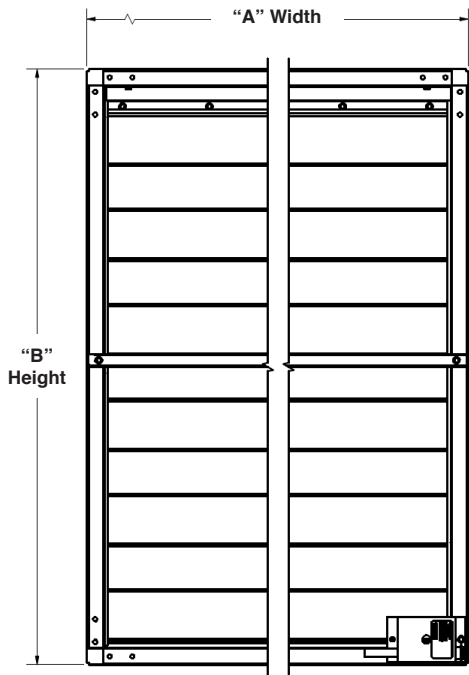

**Front View**  
(See Notes 3 & 4 on Page 1)

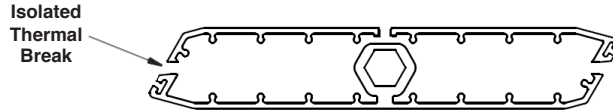

**Blade Detail**

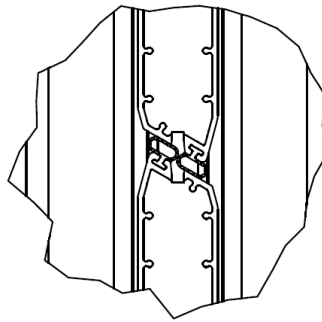

**Blade to Blade Detail**

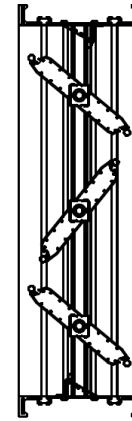

**Opposed**

## BLADE ACTION DETAIL

(Shown with thermal break frame option)

**NOTE:** To provide maximum free area and lowest pressure drop, Ruskin model TED50XT utilizes varying blade widths. In some cases, the blade extends beyond the frame a maximum of 3.06" (78).

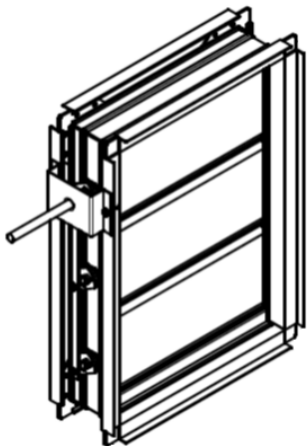

**Channel Frame Detail**  
(A and B are O.D. Frame)

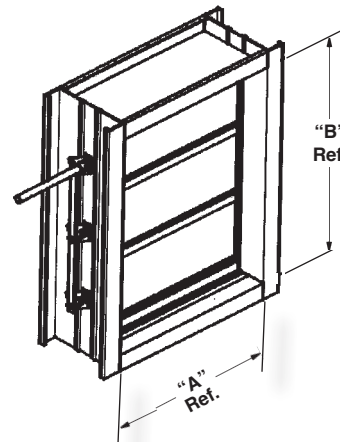
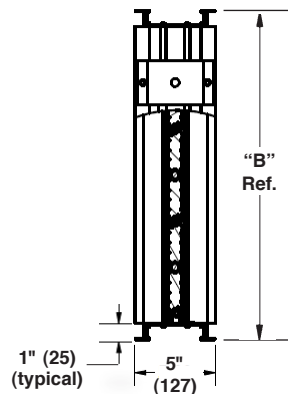

## Quick Connect "T" Flange Frame Detail

(A-Width and B-Height are I.D. Frame)

**NOTE:** Thermal break frame option is similar to graphic above. The 6" (152) x 1" (25) x .125" (3) frame is dimensioned from the inside (I.D.) and furnished actual size. Refer to Note 4 on Page 1.

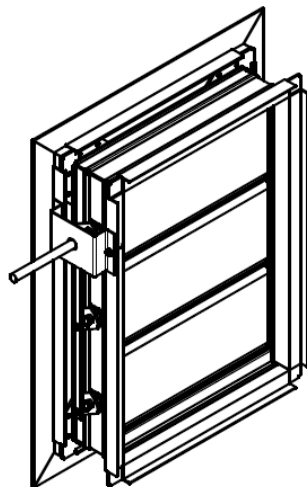

**Flange Frame Detail**  
(A and B are O.D. Frame)

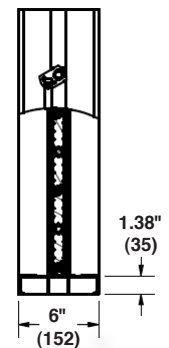
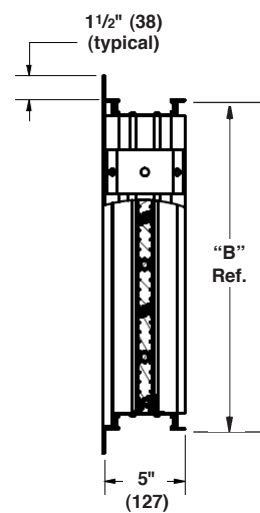

# AIR PERFORMANCE DATA

TED50XT air performance testing is performed in accordance with AMCA Standard 500-D configurations 5.2, 5.3 and 5.5 as illustrated below. All data has been corrected to standard air density of .075 lb/ft<sup>3</sup> (1.201 kg/m<sup>3</sup>).

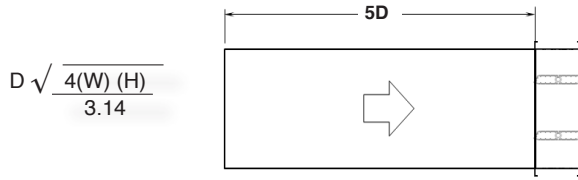

12 x 12 (305 x 305)		24 x 24 (610 x 610)		36 x 36 (914 x 914)		12 x 48 (305 x 1219)		48 x 12 (1219 x 305)	
Velocity (fpm)	Pressure Drop (in.wg)	Velocity (fpm)	Pressure Drop (in.wg)	Velocity (fpm)	Pressure Drop (in.wg)	Velocity (fpm)	Pressure Drop (in.wg)	Velocity (fpm)	Pressure Drop (in.wg)
500	0.09	500	0.03	500	0.02	500	0.03	500	0.05
1000	0.38	1000	0.11	1000	0.08	1000	0.13	1000	0.21
1500	0.85	1500	0.25	1500	0.18	1500	0.30	1500	0.47
2000	1.50	2000	0.44	2000	0.33	2000	0.52	2000	0.83
2500	2.35	2500	0.69	2500	0.51	2500	0.82	2500	1.30
3000	3.41	3000	1.00	3000	0.74	3000	1.18	3000	1.87
3500	4.64	3500	1.36	3500	1.02	3500	1.60	3500	2.51
4000	6.06	4000	1.78	4000	1.33	4000	2.09	4000	3.28

AMCA figure 5.2 was established to represent a ducted damper that is exhausting into an open area. In this configuration, entrance losses are minimized by a straight duct run upstream of the damper.

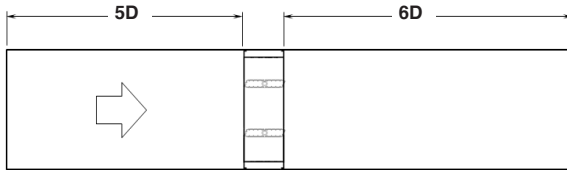

12 x 12 (305 x 305)		24 x 24 (610 x 610)		36 x 36 (914 x 914)		12 x 48 (305 x 1219)		48 x 12 (1219 x 305)	
Velocity (fpm)	Pressure Drop (in.wg)	Velocity (fpm)	Pressure Drop (in.wg)	Velocity (fpm)	Pressure Drop (in.wg)	Velocity (fpm)	Pressure Drop (in.wg)	Velocity (fpm)	Pressure Drop (in.wg)
500	0.06	500	0.01	500	0.01	500	0.02	500	0.03
1000	0.24	1000	0.06	1000	0.03	1000	0.08	1000	0.10
1500	0.54	1500	0.13	1500	0.08	1500	0.16	1500	0.24
2000	0.97	2000	0.22	2000	0.13	2000	0.28	2000	0.41
2500	1.51	2500	0.34	2500	0.20	2500	0.44	2500	0.54
3000	2.18	3000	0.49	3000	0.29	3000	0.62	3000	0.93
3500	2.96	3500	0.65	3500	0.39	3500	0.84	3500	1.27
4000	3.86	4000	0.86	4000	0.51	4000	1.07	4000	1.65

AMCA figure 5.3 was established to represent a fully ducted damper with straight duct upstream and downstream. With entrance and exit losses minimized by this straight duct arrangement, this configuration has the lowest pressure drop of all three configurations.

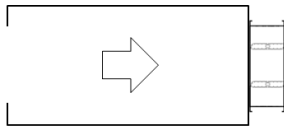

12 x 12 (305 x 305)		24 x 24 (610 x 610)		36 x 36 (914 x 914)		12 x 48 (305 x 1219)		48 x 12 (1219 x 305)	
Velocity (fpm)	Pressure Drop (in.wg)	Velocity (fpm)	Pressure Drop (in.wg)	Velocity (fpm)	Pressure Drop (in.wg)	Velocity (fpm)	Pressure Drop (in.wg)	Velocity (fpm)	Pressure Drop (in.wg)
500	0.11	500	0.05	500	0.05	500	0.05	500	0.07
1000	0.45	1000	0.19	1000	0.19	1000	0.20	1000	0.28
1500	0.95	1500	0.42	1500	0.42	1500	0.45	1500	0.62
2000	1.68	2000	0.77	2000	0.74	2000	0.79	2000	1.09
2500	2.66	2500	1.17	2500	1.16	2500	1.24	2500	1.71
3000	3.84	3000	1.67	3000	1.66	3000	1.78	3000	2.46
3500	5.22	3500	2.29	3500	2.26	3500	2.42	3500	3.35
4000	6.82	4000	2.96	4000	2.95	4000	3.16	4000	4.37

AMCA figure 5.5 was established to represent a damper installed on a plenum wall. Sudden area changes entering and exiting the damper create extreme losses, making this the highest pressure drop of the three configurations tested.

Ruskin Company certifies that model TED50XT shown herein is licensed to bear the AMCA seal. The AMCA Certified Ratings Seal applies to Air Leakage, Air Performance and Energy Efficiency ratings. The ratings shown are based on tests and procedures performed in accordance with AMCA publication 511 and comply with the requirements of the AMCA Certified Ratings Program.



## LEAKAGE DATA

Leakage testing is performed in accordance with ANSI/AMCA Standard 500-D, figure 5.5  
 Air performance testing is performed in accordance with ANSI/AMCA Standard 500-D, figures 5.2, 5.3 and 5.5  
 Data are based on a closing torque of 7 inch pounds /ft<sup>2</sup> (.79 N.m./m<sup>2</sup>) and operation between 32°-120°F (0°-49°C).

### \* Leakage Class Definitions

As defined by AMCA, the maximum allowable leakage is as follows.

Leakage Class 1A (is only defined @ 1" wg)  
 - 3 cfm/ft<sup>2</sup> (0.08 cmm/m<sup>2</sup>) @ 1" wg (0.25 kPa)

Leakage Class 1  
 - 4 cfm/ft<sup>2</sup> (0.11 cmm/m<sup>2</sup>) @ 1" wg (0.25 kPa)  
 - 8 cfm/ft<sup>2</sup> (0.23 cmm/m<sup>2</sup>) @ 4" wg (1 kPa)  
 - 11 cfm/ft<sup>2</sup> (0.31 cmm/m<sup>2</sup>) @ 8" wg (2 kPa)

TED50XT	LEAKAGE CLASS*				
	Maximum Damper Width	1" w.g. (0.25 kPa)	4" w.g. (1 kPa)	8" w.g. (2 kPa)	10" w.g. (2.5 kPa)
60" (1524)	1A	1	1	1	1



Ruskin Company certifies that model TED50XT shown herein is licensed to bear the AMCA seal. The AMCA Certified Ratings Seal applies to Air Leakage, Air Performance and Energy Efficiency ratings. The ratings shown are based on tests and procedures performed in accordance with AMCA publication 511 and comply with the requirements of the AMCA Certified Ratings Program.

## ENERGY EFFICIENCY PERFORMANCE DATA



### Ruskin model TED50XT has an AMCA certified Thermal Efficiency Ratio of 345%

Thermal Efficiency Ratio (E) is a comparison of a tested damper's thermal performance against a known reference damper. A tested damper is compared to the thermal performance of a v-groove blade reference damper. A damper with the same thermal efficiency as the reference damper would have an E value of 0%, while a damper that is four times as efficient would have an E value of 200%.

Torque, seal material, blade action, and flow direction influence thermal efficiency. Consult Ruskin for additional test data for specific application.

### Torque

Ruskin model TED50XT data are based on a closing torque of 7 inch pounds/ft<sup>2</sup> (.80 N.m./m<sup>2</sup>).

### Test Setup Information

In accordance with AMCA 500-D figure 5.10, Thermal Efficiency Test, a 36" x 36" (914 x 914) test sample is placed on the test fixture. Manufacturer's published torque is applied to hold the damper closed.

## SUGGESTED SPECIFICATION

Furnish and install, where shown on plans and/or as indicated in schedules thermally efficient extreme temperature control dampers meeting the following minimum specifications.

Damper shall be Ruskin TED50XT. Damper frame shall be constructed of 6063T6 high yield extruded aluminum with a minimum wall thickness of .125" (3) and a yield stress of no less than 30,000psi. Low pressure drop aerodynamically shaped blades shall be constructed of 6063T6 high yield extruded aluminum with a minimum wall thickness of .125" (3) and a yield stress of no less than 30,000psi. Blades shall be filled with Polyurethane structural foam with a minimum density of 15 pcf. Insulated blades shall include a thermal break positioned between two blade seals to completely eliminate a thermal path from one side of the damper to the other. Thermal breaks on the blade edges shall not be visible when the damper is in the closed position. Damper assembly shall have a symmetrical design to ensure the resistance to airflow is identical from either direction. Axles shall be 1/2" (13) hexagonal plated steel material. Stainless steel axles shall be utilized when noted on the plans. Polycarbonate bearings shall be formed to the shape of the axle to reduce leakage through the frame. Bearings shall rotate inside an Acetyl Copolymer outer bearing surface to reduce torque and promote a smooth operation throughout the stroke of the damper. Zero tolerance Swedgelock™ linkage arms shall be permanently and mechanically secured to each axle, eliminating future need for field adjustment of the linkage assembly. Linkage assembly shall be set to predetermined parameters ensuring leakage performance for the life of the product. Linkage shall be completely concealed within the damper frame, out of the airstream. Stainless steel linkage of the same design shall be used when specified on the plans. Blade edge seals shall be extruded bulb Silicone and shall be mechanically fastened to the blades. Jamb seals shall be low profile, light prohibiting, extruded Silicone secured in extruded pockets of the damper frame. Stainless steel jamb seals creating a thermal path from one side of the blade to the other are not permitted. Damper shall be suitable for pressures up to 8 inches water gage (2kPa), velocities up to 4,000 fpm (20.3 m/s), standard air leakage of less than 8 cfm/ft<sup>2</sup> at 4 inches water gage (2.44 cmm/m<sup>2</sup> at 1 kPa), temperature range of -70°F to 200°F (-57°C to 93°C) and a thermal efficiency ratio no less than 657% on opposed blade dampers. All performance data shall be submitted to engineer of record for approval. Damper leakage, performance, and thermal efficiency shall be developed in accordance with the latest edition of AMCA 500-D. Damper shall be licensed to bear the AMCA certified ratings seal for Class 1A Performance.



3900 Dr. Greaves Rd.  
 Kansas City, MO 64030  
 (816) 761-7476  
 FAX (816) 765-8955  
 www.ruskin.com