

CDR94 HIGH PRESSURE ROUND CONTROL DAMPER (40" W.G. MAX. STATIC PRESSURE)

STANDARD CONSTRUCTION

FRAME

Steel channel. See table below for web dimension and thickness.

BLADE

Steel, stiffened as required. See table below for blade thickness.

AXLE

Continuous, plated steel axle. See table below for axle diameter.

CONTROL SHAFT

Axle extends 6" (152) beyond frame.

BEARINGS

Grease lubricated ball bearings mounted outboard of frame with adjustable packing gland shaft seals.

BLADE STOP

1/2" x 1/4" (13 x 6) steel bar on dampers under 17" (432) in diameter.

1/2" x 1/2" (13 x 13) steel bar on dampers 17" (432) in diameter and larger.

FINISH

Aluminum paint with some parts mill galvanized.

MINIMUM SIZE

4" (102) diameter.

MAXIMUM SIZE

72" (1829) diameter.

MAXIMUM TEMPERATURE

250°F (121°C) is standard. Damper can be supplied for 250°F (121°C) to 400°F (204°C) temperature conditions by increasing clearance between blade and frame and by using a different bearing arrangement. Advise Ruskin of maximum operating temperature.

SHIPPING WEIGHT

48" (1219) diameter units and under – 10 lbs. per inch of inside diameter. Over 48" (1219) diameter units – 15 lbs. per inch of inside diameter.

Dimensions in parenthesis () indicate millimeters.

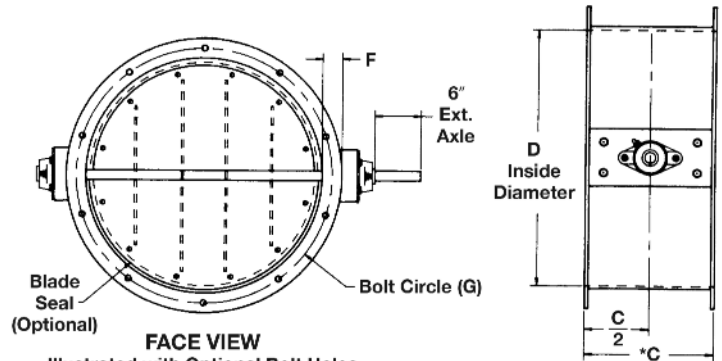

Illustrated with Optional Bolt Holes

VARIATIONS

Additional variations to those listed in table are available. Contact Ruskin for pricing.

- Heavier/higher temperature construction.
- Special finishes.
- Special materials.

D – INSIDE DIA.		FRAME		BLADE THICK.	AXLE DIA.
ABOVE	THRU	FLANGE (F)	WEB (C)		
4" (102) & above	6" (127)	1 1/4" x 10 ga. (32 x 254)	6" x 10 ga. (152 x 254)	1/4" (6)	3/4" (19)
6"	11 3/4" (294)	1 1/4" x 10 ga. (32 x 254)	9" x 10 ga. (229 x 254)	1/4" (6)	3/4" (19)
11 3/4"	14" (356)	1 1/2" x 10 ga. (38 x 254)	9" x 10 ga. (229 x 254)	1/4" (6)	1" (25)
14"	24" (356)	1 1/2" x 1/4" (38 x 6)	9" x 10 ga. (229 x 254)	1/4" (6)	1" (25)
24"	28" (610)	2" x 1/4" (51 x 6)	12" x 1/4" (305 x 6)	1/4" (6)	1" (25)
28"	36" (711)	2" x 1/4" (51 x 6)	12" x 1/4" (305 x 6)	1/4" (6)	1 1/2" (38)
36"	48" (914)	2" x 1/4" (51 x 6)	12" x 1/4" (305 x 6)	1/4" (6)	2" (51)
48"	52" (1219)	2 1/2" x 5/16" (64 x 8)	12" x 5/16" (305 x 8)	1/4" (6)	2 1/2" (64)
52"	60" (1321)	2 1/2" x 5/16" (64 x 8)	12" x 5/16" (305 x 8)	3/8" (10)	2 1/2" (64)
60"	72" (1829)	2 1/2" x 5/16" (64 x 8)	12" x 5/16" (305 x 8)	3/8" (10)	3" (76)

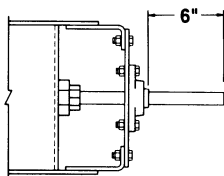

Outboard Bearings W/Shaft Seals Detail

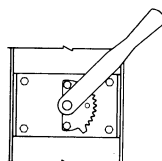

BAH Hand Quadrant (Optional)

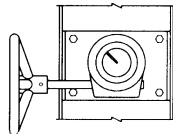

Wormgear Actuator (Optional)

FRAME	BLADE	SEALS	BEARINGS	AXLE	ACCESSORIES
STEEL CHANNEL – SEE CONSTRUCTION TABLE	STEEL STIFFENED AS REQUIRED	ADJUSTABLE PACKING GLAND SHAFT SEAL	RELUBRICABLE BALL BEARINGS MTD OUTBOARD OF FRAME	PLATED CONTINUOUS 6" EXTENSION BEYOND FRAME	BOLT HOLES IN ONE FLANGE (OPT)
304 STN STL (OPT)	304 STN STL (OPT)	NEOPRENE BLADE SEAL (OPT); MAX 250°F			BOLT HOLES IN BOTH FLANGES (OPT)
304L STN STL (OPT)	304L STN STL (OPT)	EPDM BLADE SEAL (OPT); MAX 250°F		304SS (OPT), 304L SS (OPT)	MANUAL ACTUATOR (OPT)
316 STN STL (OPT)	316 STN STL (OPT)	SILICONE BLADE SEAL (OPT); MAX 400°F		316SS (OPT)	ELECTRIC ACTUATOR (OPT)
316L STN STL (OPT)	316L STN STL (OPT)	VITON BLADE SEAL (OPT); MAX 400°F		316L SS (OPT)	PNEUMATIC ACTUATOR (OPT)
		TETRAGLASS BLADE SEAL (OPT); MAX 1000°F			

QTY.	FRAME				BOLT HOLE ORIENT.		COMMENTS	TAG
	D Diameter	Q Bolt Circle Diam.	H No. Holes	M Hole Diam.	S Straddle	T Parallel		
JOB CONTRACTOR				LOCATION				

CDR94 SUGGESTED SPECIFICATION

Furnish and install, at locations shown on plans or in accordance with schedules, heavy duty industrial grade control dampers meeting the following specifications: Dampers shall be butterfly type consisting of circular blade, mounted to axle within formed flanged frame. Frames shall be constructed of steel channel and shall have full circumference blade stop located in airstream. Damper shaft shall be continuous, solid cold rolled steel extending through entire diameter of damper and beyond damper bearing a minimum of 6 inches. Axles shall be supported in sealed, relubricable ball bearings mounted outboard of frame. Press fit or bolt on bearings are not acceptable. Damper frame and blade shall be fabricated from

hot rolled steel. All parts not otherwise protected shall be given one coat of aluminum paint. Damper leakage shall not exceed (specifier select) 35 total CFM with blade seals (or) 175 total CFM with full circumference blade stop based on 48" diameter unit at 1" W.G. Maximum pressure drop across a 48" diameter damper shall be less than .01" W.G. at 10,000 CFM. Submittal shall include published performance data on a complete range of damper sizes developed from testing in accordance with AMCA Standard 500 in an AMCA registered laboratory. Damper shall be Ruskin model CDR94.

CDR94 PERFORMANCE DATA

DAMPER LEAKAGE

Damper Diameter	Maximum System Pressure	Maximum System Velocity	Leakage with seals*		Leakage without seals*	
			% of max. flow	Total CFM	% of max. flow	Total CFM
72" (1829)	40" w.g.	7000 fpm	.030	60	.139	275
60" (1524)	40" w.g.	7000 fpm	.033	45	.164	225
48" (1219)	40" w.g.	7000 fpm	.040	35	.199	175
36" (914)	40" w.g.	7000 fpm	.057	28	.253	125
24" (610)	40" w.g.	7000 fpm	.114	25	.387	85
12" (305)	40" w.g.	7000 fpm	.273	15	.909	50

*Leakage information based on pressure differential of 1" w.g.

LEAKAGE CORRECTION FACTOR

Static Pressure (in. w.g.)	1	2	3	4	5	6	7	8	9	10	11	12	13	14	15	16	17
Correction Factor	1.0	1.4	1.7	2.0	2.2	2.4	2.6	2.8	3.0	3.2	3.3	3.5	3.6	3.7	3.9	4.0	4.1

DETERMINING LEAKAGE

To determine leakage at static pressure differentials higher than one inch water gage, multiply leakage at one inch (determined from table) by correction factor for higher static pressure (determined from the Leakage Correction Factor Table).

Leakage ratings are based on AMCA Standard 500 using Test Setup Apparatus Figure 5.5. Torque applied holding damper closed at 10 in. lbs. per sq. ft. of damper with minimum of 20 in. lbs.

Dampers may tolerate higher pressures and velocities than those listed here. Conservative ratings are presented intentionally in an effort to avoid misapplication. Consult Ruskin or your Ruskin representative when damper is to be applied in conditions exceeding recommended maximums.

PRESSURE DROP - DAMPER OPEN

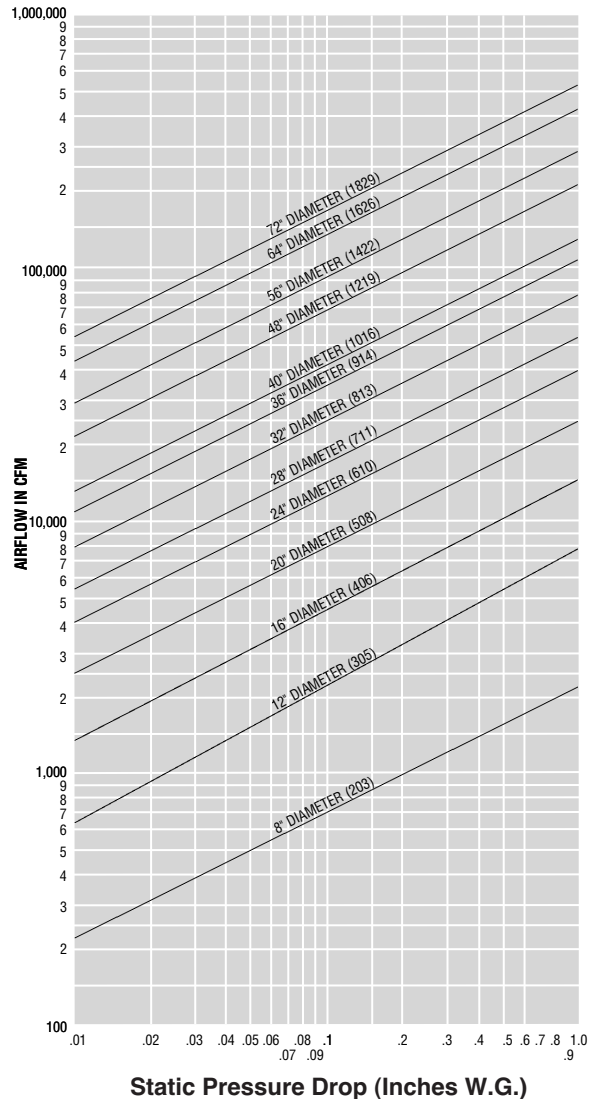

Performance curves based on AMCA Standard 500 using test setup apparatus figure 5.3 (damper installed with duct upstream and downstream). Static pressure and CFM are corrected to .075 lb/cu ft air density.



3900 Dr. Greaves Rd.
 Kansas City, MO 64030
 (816) 761-7476
 FAX (816) 765-8955
 www.ruskin.com