



1749 East Highwood Road
Pontiac, Michigan 48340 USA
248-332-3900
www.ap-c.com
January, 2009

HS-100 Series Plenum Smoke Detector Expanded Application to Include Commercial Rooftop HVAC Package Units

1. Introduction

This Application Note serves to provide additional code-compliant interpretations of the HS-100 application when deployed in HVAC Commercial Rooftop Package Units, and does not necessarily imply universal compatibility with HVAC Commercial Rooftop Package Units.

2. Problem Statement and Previous Options

Code requires air duct smoke detectors be present to perform common shutdown functions in commercial applications where greater than five (5) ton HVAC Commercial Rooftop Package Units units are installed. Traditional sampling-tube style air duct smoke detectors have been the only solution to meet code, and are typically labor-intensive, multi-part “nuisance” products requiring installation in space-limited environments, often out-of-doors.

3. Air Products and Controls (APC) Solution

The **HS-100 Series Plenum Smoke Detector** (-N, Ionization; -P, Photoelectric) allows mechanical installers and contractors an alternate application compliant with code regulations set by NFPA, ICC, IBC and other jurisdictional authorities.

Advantages offered by the HS-100 include the ability to install this detector inside the plenum return of a Rooftop Package Unit without the additional labor and cost associated with traditional sampling-tube style in-duct smoke detectors. Cost savings may include reduced labor, the elimination of sampling tubes and/or a weatherproof enclosure, depending on installation location and application.

The HS-100 is UL-approved for interconnection with APC SL-2000 Series and SM-501 Series sample-tube style air duct smoke detectors where common shutdown is desired. The HS-100 offers compatibility with the complete range of APC remote accessories, typically required for each installation by code and jurisdiction.

The installation manual for the HS-100 (APD0332) details the application requirements and, in all instances, must be followed for compliant installation, testing and maintenance functions of the unit.

4. Implementation Considerations

4.1 Air Velocity Compatibility

Duct smoke detectors are tested to standards set by a Nationally Recognized Testing Laboratory (such as UL) to determine compatibility with code. The standard and subsequent “Listing” for air velocity in duct smoke detectors is measured in linear feet per minute. Package Units typically have air velocity measured in cubic feet. In order to determine whether the HS-100 is a suitable application for a given Package Unit’s air velocity, a mathematical conversion is required (see fig. 1).

HVAC Commercial Rooftop Package Units typically put out 400cfm per ton (refer to unit specifications by manufacturer). To determine the square footage of the plenum return opening, multiply the linear foot measurement of height by the linear foot measurement of width at the desired mounting location of the HS-100 unit. For example:

$$\begin{aligned} &30 \text{ ton Package Unit puts out } 12,000\text{cfm} \\ &24\text{in high} \times 30\text{in wide} = 2\text{ft} \times 2.5\text{ft} = 5 \text{ square feet (ft}^2\text{)} \\ &12,000\text{cfm} \div 5 \text{ ft}^2 \text{ plenum} = 2,400 \text{ fpm} \end{aligned}$$

fig. 1

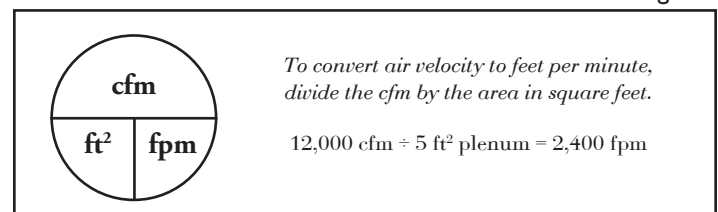

The airflow present at the HS-100 unit must be a representative sample of the air moving through the HVAC system.

4.2 Mounting Location

When determining mounting location, refer to NFPA 2007 Edition Annex A section A.5.16.4.2.2 and the associated diagrams. This section discusses the location of smoke detectors in Return Air System Openings and is especially important if the plenum space is greater than 36 inches in width or height, and where within the opening the detector is placed.

Basically, for widths and heights less than 36 inches, the detector is to be centered in the opening. When greater than 36 inches but less than 72 inches, two detectors are required at the one-quarter points of the opening; and over 72 inches, one additional detector is required for each full 24 inches of opening (see fig 2).

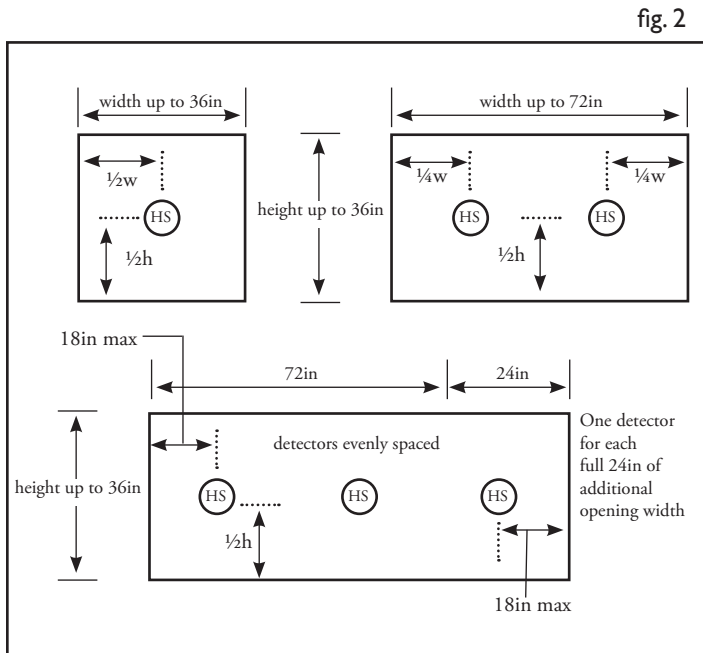

fig. 2

4.3 Configuration within Plenum Return Opening

When mounted in a Package Unit's return plenum, it is critical that the smoke-sensor is situated such that the airstream flows through the head and not directly at the head (see fig. 3).

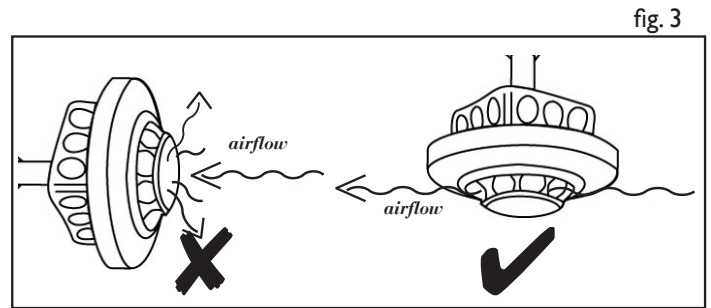

fig. 3

4.4 Sample Configurations

Sample installation locations for placement of the HS-100 duct smoke detector in the plenum return in a generic Package Unit are shown in fig. 4.

Additional Notes:

Access doors large enough to permit installation, testing and maintenance must be provided. Access shall be identified with letters at least 1/2in high to indicate the location of the device within.

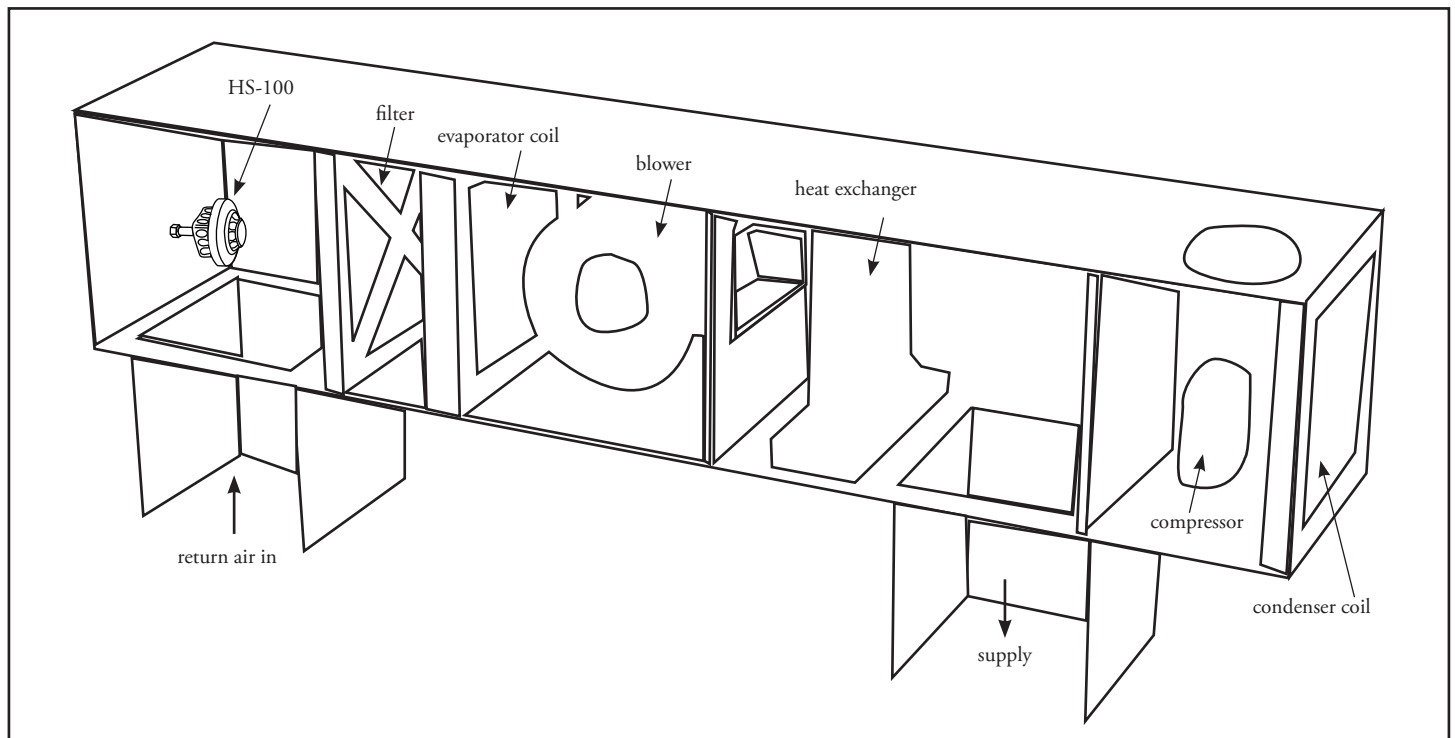

fig. 4