

## ELM6DW DRAINABLE ADJUSTABLE WAREHOUSE LOUVER EXTRUDED ALUMINUM

### APPLICATION

The Architecturally pleasing Ruskin ELM6DW warehouse louver has a 6" deep frame with adjustable drainable 37½ degree angled blades. The ELM6DW is specifically designed to provide high rates of ventilation air and boasts the industries best water penetration, perfect for warehouse applications. Factory mounted and commissioned electric or pneumatic actuators are available upon request.

### STANDARD CONSTRUCTION

#### FRAME

6" (152) deep, 6063T6 extruded aluminum with .081" (2.1) nominal wall thickness. Downspouts and caulking surfaces provided.

#### BLADES

6063T6 extruded aluminum with .081" (2.1) nominal wall thickness. Drainable blades are adjustable to 37½° angle and blade spacing is approximately 6" (152) center to center.

#### SCREEN

5/8" x .040 (16 x 1) expanded, flattened aluminum bird screen in removable frame. Screen adds approximately 1/2" (13) to louver depth.

#### SEALS

Flexible, compressible aluminum jamb seals.

#### BEARINGS

Stainless steel sleeve pressed into frame.

#### AXLES

1/2" (13) plated steel hex.

#### FINISH

Mill.

#### LINKAGE

Concealed in frame.

#### ACTUATOR

Locking louver quadrant.

#### MINIMUM SIZE

12"w x 12"h (305 x 305).

#### APPROXIMATE SHIPPING WEIGHT

3.5 lbs. / ft² (17.1 kg per m²).

#### MAXIMUM FACTORY ASSEMBLY SIZE

Shall be 60" x 96" (1524 x 2438) without seals. Louvers with standard jamb seals and/or optional blade seals shall be 48" x 96" (1219 x 2438). Standard construction includes jamb seals. Louvers larger than the maximum factory assembly size will require field assembly of smaller sections.

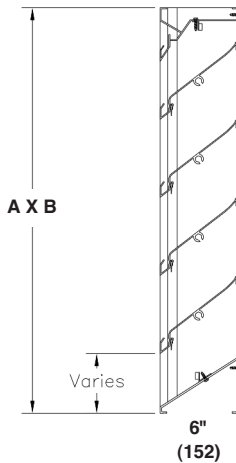

### FEATURES

The ELM6DW offers:

- Published performance ratings based on testing in accordance with AMCA Publication 500-L.
- Low torque operation and architecturally pleasing appearance with low leakage performance.
- Drain gutter in the head frame and each blade; downspouts in jambs and mullions to drain water from louver for minimum water cascade from blade to blade.
- Concealed blade linkage is protected from weather exposure and reduces required installation depth.
- Jamb seals provide tight blade-to-frame closure.

### VARIATIONS

Ruskin model ELM6DW is available with the following variations at additional cost.

- Blade edge seals.
- Front or rear flange frame.
- Filter racks.
- Extended sill.
- Front and rear security bars
- A variety of bird and insect screens that can be mounted on rear or front of louver
- Factory mounted and commissioned electric and pneumatic actuators, chain pull devices and manual locking handles.
- Selection of finishes: Prime coat, 50% PVDF (modified fluoropolymer), Epoxy, Pearledize, 70% PVDF, Clear and Anodized finishes. (Some variation in anodize color consistency is possible)
- Factory mounted sleeves

Consult Ruskin for other special requirements.

### FRAME CONSTRUCTION

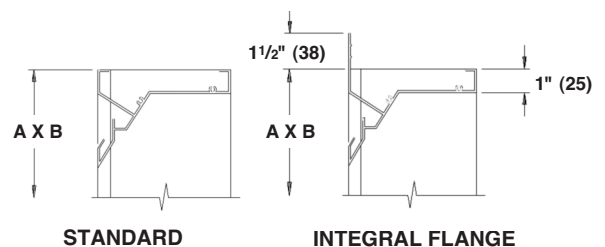

Dimensions in inches, parenthesis ( ) indicate millimeters.

Units furnished 1/4" (6) smaller than given opening dimensions.

TAG	QTY.	SIZE		FRAME	VARIATIONS
		A*-WIDE	B*-HIGH		

**PROJECT**  
**ARCH./ENGR.**  
**REPRESENTATIVE**

**LOCATION**  
**CONTRACTOR**  
**DATE**

## SUGGESTED SPECIFICATIONS

Furnish and install at locations shown on plans or as described in schedules. Adjustable louvers to incorporate drainable adjustable blades in a single 6" (152) deep frame. Adjustable louvers shall be manufactured in an ISO-9001 certified factory

Louver sizes too large for shipping shall be built up by the contractor from factory assembled louver sections to provide overall sizes required. Louver design shall incorporate structural supports required to withstand a wind load of 20 lbs. per sq. ft. (.96kPa). Adjustable louvers shall be furnished with bird and or insect screens, quadrant arm, electric, pneumatic or manual actuators, supports and finishes as specified and as required for a complete installation.

Louvers shall be Ruskin Model ELM6DW extruded 6063T6 aluminum alloy construction as follows:

### MATERIAL

Frame: .081 (2.1) wall thickness, caulking surfaces provided.  
 Blades: .081 (2.1) thick drainable blades are adjustable to 37½ degree angle with 6" (152) center to center blade spacing. Blades overlapping frames is unacceptable.

Bearings: Stainless steel sleeve bearings pressed into frame  
 Axle: ½" (13) diameter hexagonal positively locked into the louver blade.  
 Linkage: Concealed out of airstream, within the louver frame to reduce pressure drop and noise  
 Jamb Seals: Stainless steel compression type to prevent leakage between blade end and damper frame  
 Screen: 5/8" x .040 (16 x 1) expanded flattened aluminum bird screen in removable frame.  
 Finish: Select finish specification from Ruskin Finishes Brochure.

Published louver performance data bearing the AMCA Certified Ratings Seal for Air Performance must be submitted for approval prior to fabrication and must demonstrate pressure drop and water penetration equal to or less than the Ruskin model specified. Moveable Warehouse louver shall be in all respects equivalent to the Ruskin model ELM6DW.

## PERFORMANCE DATA

AMCA Standard 500 provides a reasonable basis for testing and rating louvers. Testing to AMCA 500 is performed under a certain set of laboratory conditions. This does not guarantee that other conditions will not occur in the actual environment where louvers must operate.

The louver system should be designed with a reasonable safety factor for louver performance. To ensure protection from water carry-over, design with a performance level somewhat below maximum desired pressure drop and .01 oz./sq. ft. of water penetration.

### WATER PENETRATION

Test size 48" wide x 48" high (1219 x 1219)

Beginning point of water penetration at .01 oz./sq. ft. is 1155 fpm (352 m/min).

Per AMCA Test #30331-W1

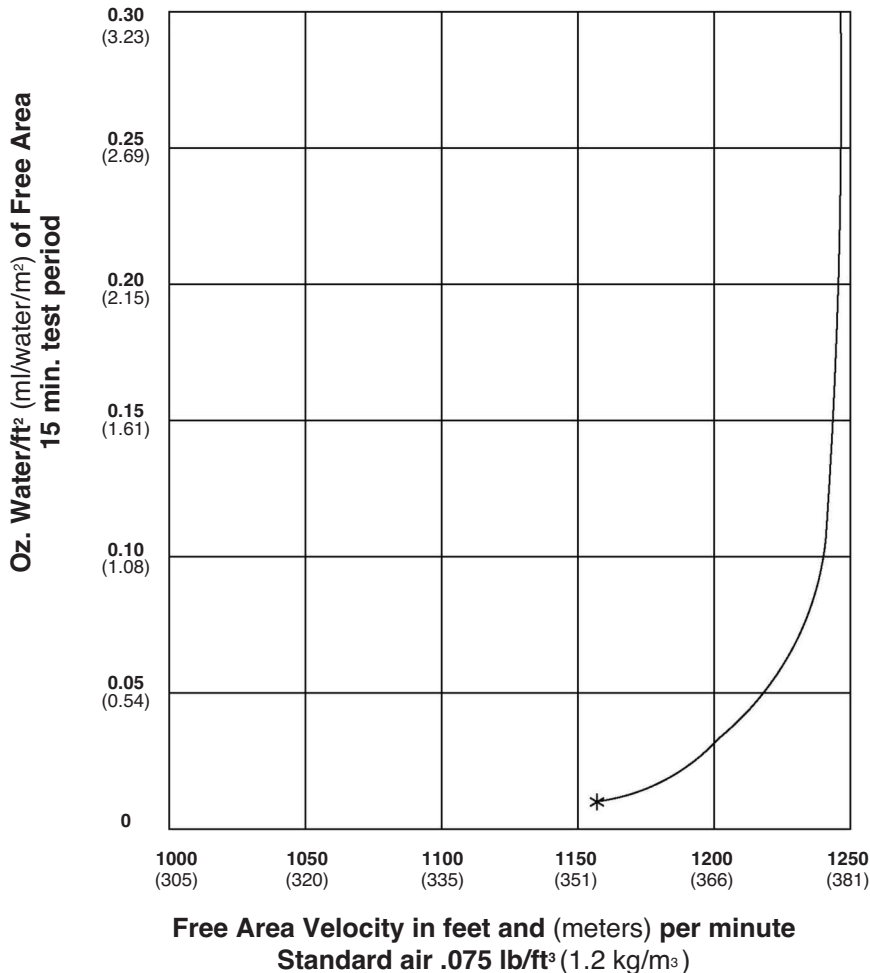

Ruskin Manufacturing Company certifies that the ELM6DW Louvers shown herein are licensed to bear the AMCA Seal. The ratings shown are based on tests and procedures performed in accordance with AMCA Publication 511 and comply with the requirements of the AMCA Certified Ratings Program. The AMCA Certified Ratings Seal applies to air performance and water penetration ratings only.

# PRESSURE DROP

Test size 48" wide x 48" high (1219 x 1219)

Ratings do not include the effect of a bird screen.

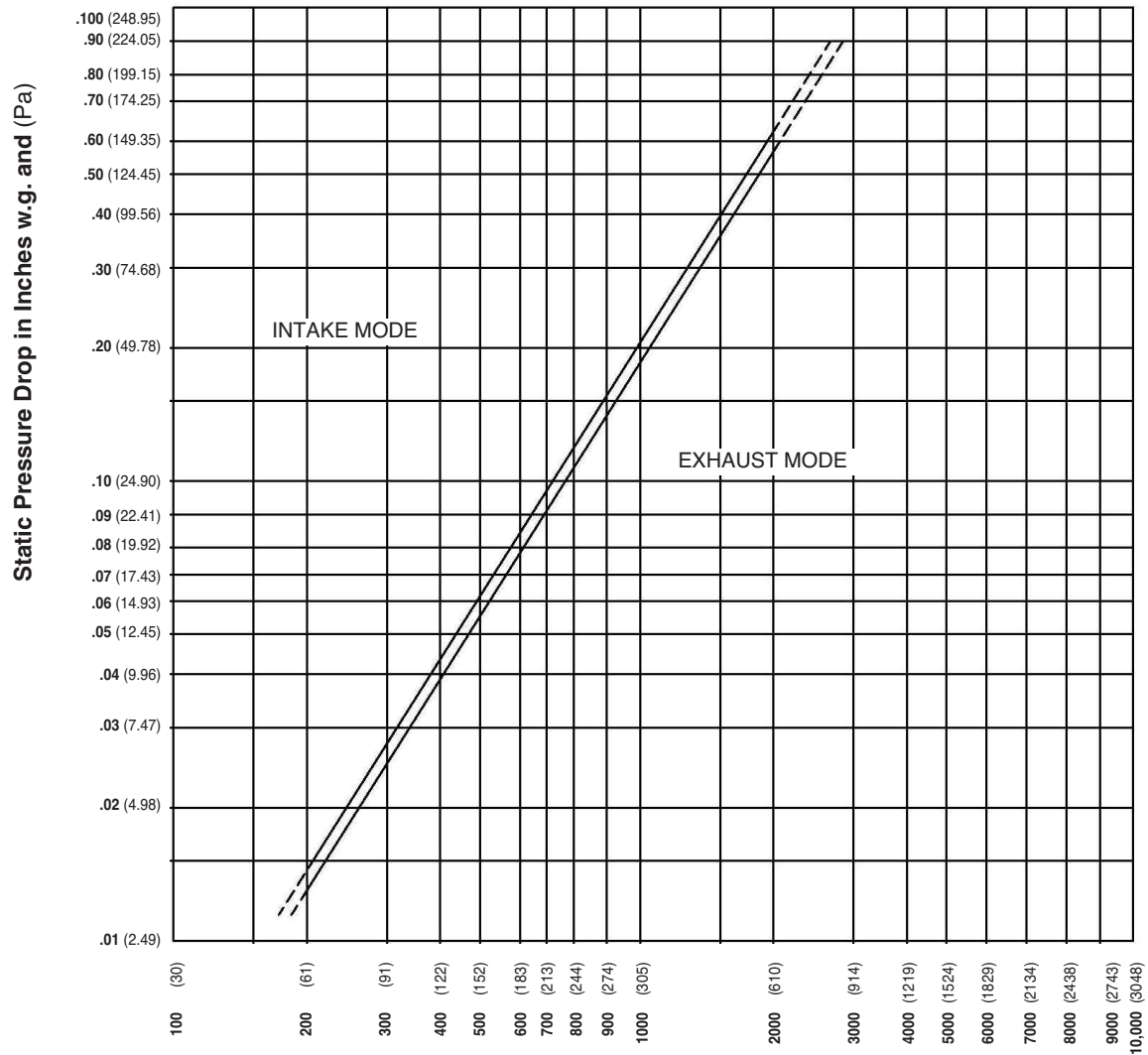

**Air Velocity in feet (meters) per minute through Free Area**  
Louver tested for water penetration and pressure drop with jamb seals.  
Per AMCA Test #25587-E1

## AIR LEAKAGE WITH BLADES CLOSED

Leakage at 1" w.g. (248.9) static pressure drop is 10.8 CFM per ft.<sup>2</sup> and (m<sup>2</sup>).

Louver tested for air leakage with jamb seals and optional blade seals.

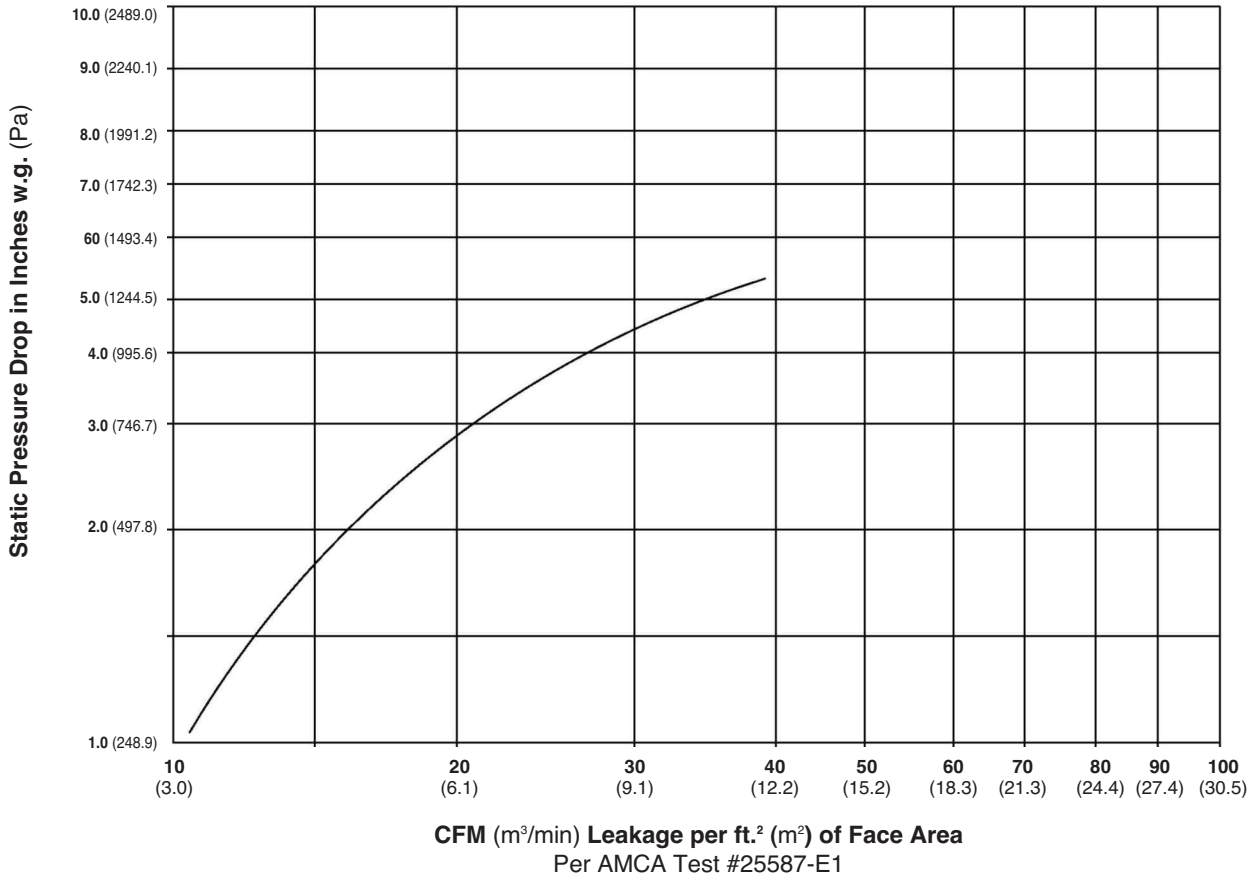

## FREE AREA GUIDE

Free Area Guide shows free area in ft<sup>2</sup> and m<sup>2</sup> for various sizes of ELM6DW.

Width – Inches and Meters

	12 0.30	18 0.46	24 0.61	30 0.76	36 0.91	42 1.07	48 1.22	54 1.37	60 1.52
12 0.30	0.30 0.03	0.48 0.04	0.65 0.06	0.83 0.08	1.01 0.09	1.19 0.11	1.37 0.13	1.49 0.14	1.66 0.15
18 0.46	0.52 0.05	0.84 0.08	1.15 0.11	1.47 0.14	1.78 0.17	2.09 0.19	2.41 0.22	2.62 0.24	2.93 0.27
24 0.61	0.75 0.07	1.20 0.11	1.65 0.15	2.10 0.20	2.55 0.24	3.00 0.28	3.45 0.32	3.75 0.35	4.20 0.39
30 0.76	0.98 0.09	1.56 0.15	2.15 0.20	2.73 0.25	3.32 0.31	3.90 0.36	4.49 0.42	4.88 0.45	5.47 0.51
36 0.91	1.20 0.11	1.92 0.18	2.65 0.25	3.37 0.31	4.09 0.38	4.81 0.45	5.53 0.51	6.01 0.56	6.73 0.63
42 1.07	1.43 0.13	2.29 0.21	3.14 0.29	4.00 0.37	4.86 0.45	5.71 0.53	6.57 0.61	7.14 0.66	8.00 0.74
48 1.22	1.66 0.15	2.65 0.25	3.64 0.34	4.63 0.43	5.63 0.52	6.62 0.62	7.61 0.71	8.28 0.77	9.27 0.86
54 1.37	1.88 0.17	3.01 0.28	4.14 0.38	5.27 0.49	6.40 0.59	7.53 0.70	8.65 0.80	9.41 0.87	10.54 0.98
60 1.52	2.11 0.20	3.37 0.31	4.64 0.43	5.90 0.55	7.17 0.67	8.43 0.78	9.70 0.90	10.54 0.98	11.80 1.10
66 1.68	2.33 0.22	3.73 0.35	5.13 0.48	6.54 0.61	7.94 0.74	9.34 0.87	10.74 1.00	11.67 1.09	13.07 1.22
72 1.83	2.56 0.24	4.10 0.38	5.63 0.52	7.17 0.67	8.71 0.81	10.24 0.95	11.78 1.10	12.80 1.19	14.34 1.33
78 1.98	2.79 0.26	4.46 0.41	6.13 0.57	7.80 0.73	9.47 0.88	11.15 1.04	12.82 1.19	13.93 1.30	15.61 1.45
84 2.13	3.01 0.28	4.82 0.45	6.63 0.62	8.44 0.78	10.24 0.95	12.05 1.12	13.86 1.29	15.07 1.40	16.87 1.57
90 2.29	3.24 0.30	5.18 0.48	7.13 0.66	9.07 0.84	11.01 1.02	12.96 1.21	14.90 1.39	16.20 1.51	18.14 1.69
96 2.44	3.47 0.32	5.55 0.52	7.62 0.71	9.70 0.90	11.78 1.10	13.86 1.29	15.94 1.48	17.33 1.61	19.41 1.80

Height – Inches and Meters

# TYPICAL INSTALLATION DETAILS

**Masonry Wall**

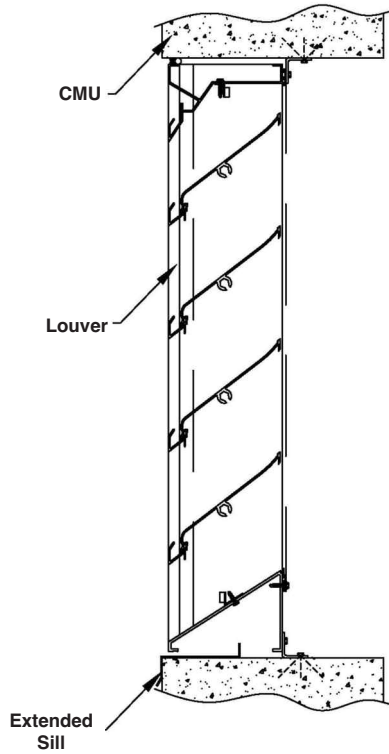

**Metal Panel Wall**

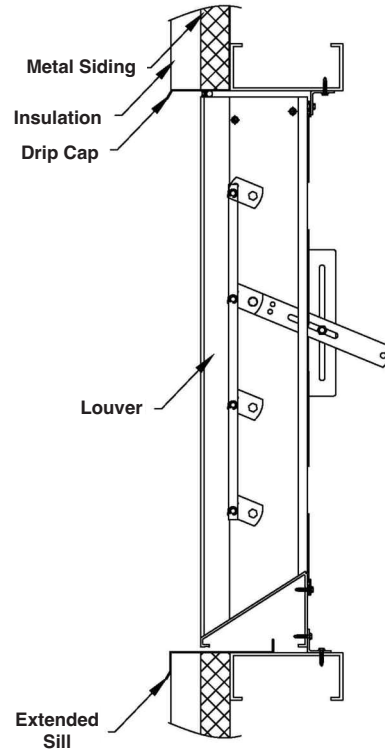

**Wood Installation**

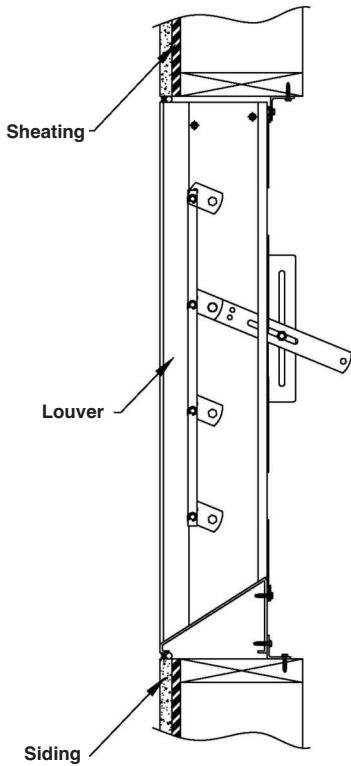

**Flange Mount**

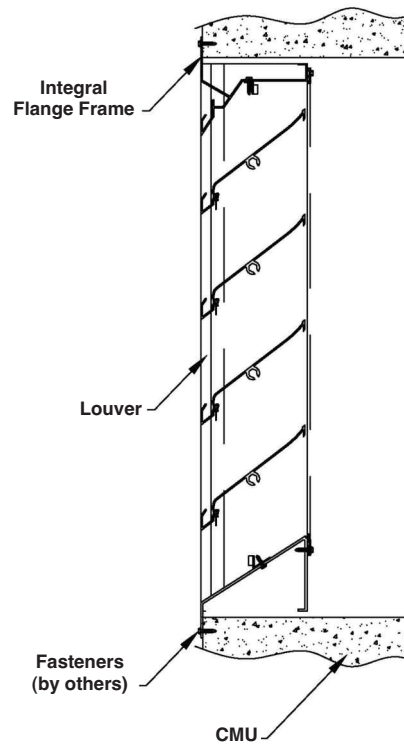

Accessories at additional cost.

**RUSKIN**®

3900 Dr. Greaves Rd.  
 Kansas City, MO 64030  
 (816) 761-7476  
 FAX (816) 765-8955  
 www.ruskin.com