

## MS4104, MS4109, MS4604, MS4609, MS8104, MS8109 Fast-Acting, Two-Position Actuators FOR FIRE/SMOKE CONTROL APPLICATIONS

### PRODUCT DATA



### APPLICATION

The MS4104, MS4109, MS4604, MS4609, MS8104 and MS8109 Fast-Acting, Two-Position Actuators are spring return direct coupled actuators (DCA) for Fire and Smoke dampers (on/off control). The actuator accepts an on/off signal from a single-pole, single-throw (SPST) controller. Reversible mounting allows actuator to be used for either clockwise (cw) or counterclockwise (ccw) spring rotation.

### FEATURES

- 30 lb-in. (3.4 N•m) or 80 lb-in. (5.9 N•m) minimum driving torque at 350°F (176°C).
- Reversible mounting facilitates use in either clockwise (cw) or counterclockwise (ccw) spring rotation.
- Integral spring return ensures level of return torque.
- Fifteen-second spring return timing.
- No special cycling required during long-term holding. (See Operation section.)
- No audible noise during holding.
- Patent pending design eliminates need for limit switches to reduce power consumption.
- Models available for 24, 120, and 230 Vac.
- Ninety-five degree angle of rotation.
- Actuator holds rated torque at reduced power level.
- Die-cast aluminum housing.
- Housing design allows flush mounting to damper.
- Designed to operate reliably in smoke control systems requiring Underwriter's Laboratories Inc. UL555S ratings up to 350°F.
- Models available with SPST position-indicating switches (7°, 85° stroke).

### Contents

Application .....	1
Features .....	1
Specifications .....	2
Ordering Information .....	2
Installation .....	4
Operation .....	6
Checkout .....	6



# SPECIFICATIONS

**Models:** See Table 1.

**Table 1. Models.**

Model	Voltage (Vac)	Internal Auxiliary Switches
MS4104F1010	120	None
MS4104F1210	120	2 SPST <sup>a</sup>
MS4109F1010	120	None
MS4109F1210	120	2 SPST <sup>a</sup>
MS4604F1010	230	None
MS4604F1210	230	2 SPST <sup>a</sup>
MS4609F1010	230	None
MS4609F1210	230	2 SPST <sup>a</sup>
MS8104F1010	24	None
MS8104F1210	24	2 SPST <sup>a</sup>
MS8109F1010	24	None
MS8109F1210	24	2 SPST <sup>a</sup>

<sup>a</sup> Internal switches are designed to pass UL555S requirements (at 350°F).

**Dimensions:** See Fig. 1.

**Minimum Damper Shaft Length:** 2 in. (51 mm).

**Device Weight:** 5 lb (2.3 kg).

**Stroke:** 95° ± 3°, mechanically limited.

**Electrical Ratings:** See Table 2.

**Electrical Connections:**

Power Lead Wires:

MS410xF and MS460xF: 32 inches (0.8m), 18 AWG

MS810xF: 39 inches (1m), 18 AWG

**Switch Lead Wires:** 18 inches, 18 AWG, 2 color coded leads

**Mounting:** Round 1/2 inch shaft adapter with 1/4 inch set screws.

## IMPORTANT

Honeywell does not recommend using linkages with these actuators because side-loading of the output hub reduces actuator life.

## Temperature Ratings:

Ambient: 0°F to 130°F (-18°C to 55°C).

Shipping and Storage: -40°F to 140°F (-40°C to 60°C).

## IMPORTANT

The actuator is designed to meet UL555S standards at 350°F (176°C). The actuator must be tested with the damper to achieve this rating.

**Humidity Ratings:** 5% to 95% RH noncondensing.

## Noise Rating (Maximum):

Driving Open: 80 dBA at 1m.

Holding: 20 dBA at 1m (no audible noise).

## Controller Type:

MS4104, MS4109: Line voltage (120 Vac), two-position, SPST (Series 40).

MS4604, MS4609: Line voltage (230 Vac), two-position, SPST (Series 40).

MS8104, MS8109: Low voltage (24 Vac), two-position, SPST (Series 80).

**Table 2. MS4104, MS4109, MS4604, MS4609, MS8104 and MS8109 DCA Models.**

Model	Power Consumption		Torque in lb-in. (N•m)	Voltage Input in Vac
	Running	Holding		
MS4104F	0.18A, 18W	0.11A, 9W	30 (3.4)	120 ±10%, 50/60 Hz
MS4109F	0.25A, 23W	0.13A, 7W	80 (9)	
MS4604F	0.13A, 18W	0.10A, 11W	30 (3.4)	230 ±10%, 50/60 Hz
MS4609F	0.13A, 23W	0.09A, 7W	80 (9)	
MS8104F	16 VA	8 VA	30 (3.4)	24Vac/dc +20%, -10%, 50/60 Hz
MS8109F	23 VA	7 VA	80 (9)	

## Torque Rating (at rated voltage):

Spring Return:

MS4104F, MS4604F, MS8104F: 30 lb-in. (3.4 N•m).

MS4109F, MS4609F, MS8109: 80 lb-in. (9 N•m).

Stall Maximum:

MS4104F, MS4604F, MS8104F: 150 lb-in. (17 N•m).

MS4109F, MS4609F, MS8109: 240 lb-in. (27 N•m).

350°F Driving:

MS4104F, MS4604F, MS8104F: 30 lb-in. (3.4 N•m).

MS4109F, MS4609F, MS8109: 80 lb-in. (9 N•m).

# ORDERING INFORMATION

When purchasing replacement and modernization products from your TRADELINE® wholesaler or distributor, refer to the TRADELINE® Catalog or price sheets for complete ordering number. If you have additional questions, need further information, or would like to comment on our products or services, please write or phone:

1. Your local Honeywell Environmental and Combustion Controls Sales Office (check white pages of your phone directory).
2. Honeywell Customer Care  
1885 Douglas Drive North  
Minneapolis, Minnesota 55422-4386
3. <http://customer.honeywell.com> or <http://customer.honeywell.ca>

International Sales and Service Offices in all principal cities of the world. Manufacturing in Belgium, Canada, China, Czech Republic, Germany, Hungary, Italy, Mexico, Netherlands, United Kingdom, and United States.

**Timing (At Rated Torque and Voltage):**

Drive Open: 15 seconds typical.  
Spring Close: 15 seconds typical.

**Cycling Requirements:**

Prolonged holding-period (1 year) testing of these actuators has been performed with no spring return failures. The actuator and the internal spring are designed to require no special cycling during long-term holding.

Honeywell recommends following all local, state and national codes for periodic testing of the entire smoke control system. Refer to National Fire Protection Association (NFPA) National Fire Codes®: NFPA90A, NFPA92A and NFPA92B for your application.

NFPA recommends periodic examination of each fire/smoke damper (semi-annually or annually) to ensure proper performance.

**Design Life (at Rated Voltage):** 30,000 full stroke cycles.

**Approvals:** See Table 3.

**Environmental Protection Ratings:** See Table 4.

**Accessories:**

205649 Mounting Bracket (not supplied with actuator).

**Table 3. Approvals.**

	MS4104F, MS4109F, MS4604F, MS4609F	MS8104F, MS8109F
UL/cUL	X	X
UL873	X	X
CE	X	X
C-Tick	X	X

**Table 4. Environmental Ratings.**

All Devices	MS4104, MS4109, MS4604, MS4609, MS8104 and MS8109
NEMA1	IP40

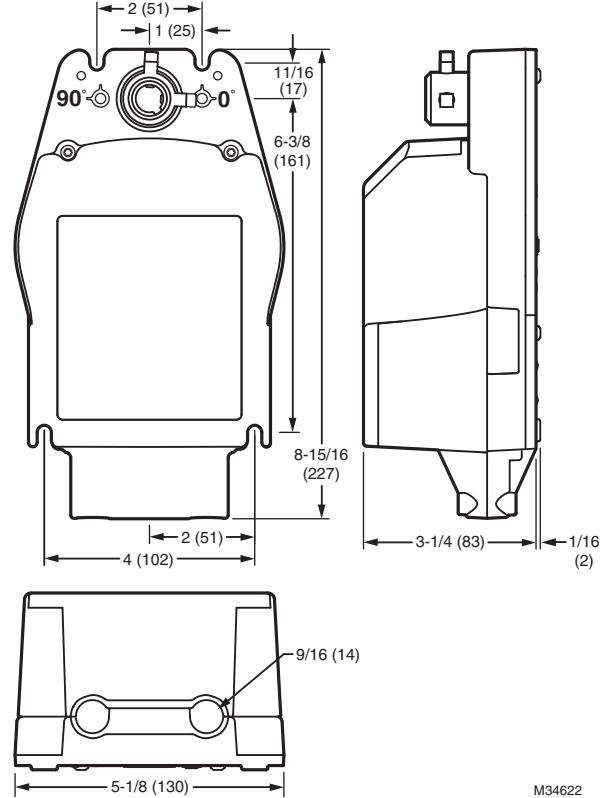

M34622

**Fig. 1. MS4104, MS4109, MS4604, MS4609, MS8104 and MS8109 dimensional drawing in in. (mm).**

# INSTALLATION

## When Installing this Product...

1. Read these instructions carefully. Failure to follow them could damage the product or cause a hazardous condition.
2. Check the ratings given in the instructions and on the product to make sure the product is suitable for your application.
3. Installer must be a trained, experienced service technician.
4. After installation is complete, check out product operation as provided in these instructions.

**IMPORTANT**

*All wiring must agree with applicable codes, ordinances and regulations.*

### **WARNING**

**Electrical Power Hazard.**  
**Line voltage can cause death or serious injury and short equipment circuitry.**  
 Disconnect power supply before installation.

### **CAUTION**

**Electrical Shock or Equipment Damage Hazard.**  
**Low voltage can shock individuals or short equipment circuitry.**  
 Disconnect power supply before installation.

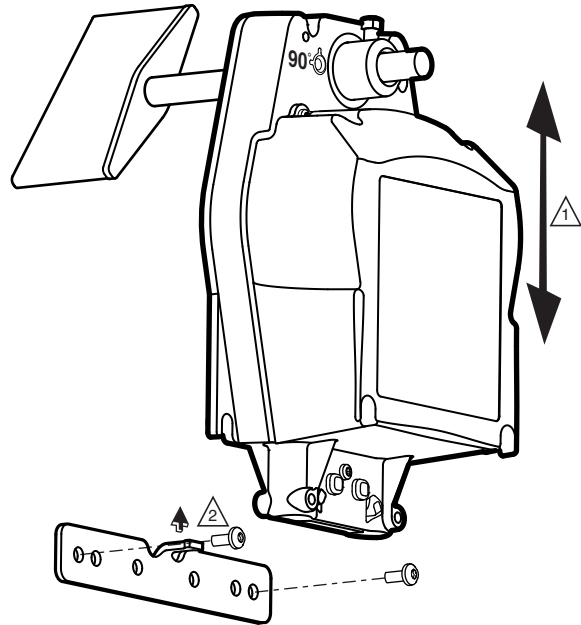



**1** ENSURE THAT MOUNTING ASSEMBLY PREVENTS ACTUATOR ROTATION AND ALLOWS ACTUATOR TO FLOAT ALONG INDICATED AXIS. WHEN TOO TIGHT, THE RESULTING BINDING CAN DAMAGE THE ACTUATOR OR REDUCE TORQUE OUTPUT.

**2** ACCESSORY MOUNTING BRACKET IS NOT SUPPLIED WITH THE ACTUATOR.

M34623

**Fig. 2. Mounting actuator to damper housing.**

## Location and Mounting

The actuators are designed to open a damper by driving the damper shaft in either clockwise  or counterclockwise  direction. The actuator housing has two slots on the bottom that, with a 205649 Mounting Bracket, secure it flush to a damper box (see Fig. 2). When mounted correctly, these slots allow the actuator to *float* without rotating relative to the damper shaft.

### **CAUTION**

**Equipment Damage Hazard.**  
**Tightly securing actuator to damper housing can damage actuator.**  
 Mount actuator to allow it to float along its vertical axis.

## Preparation

Before mounting the actuator onto the damper shaft, determine the:

- Damper/valve opening direction for correct spring return rotation. The actuator can be mounted to provide clockwise or counterclockwise spring return.
- Damper shaft size (see Specifications section).

## Installation



### CAUTION

**Device Malfunction Hazard.**  
Improper set screw tightening causes device malfunction.

Tighten set screws with proper torque to prevent damper shaft slippage.



### CAUTION

**Actuator Damage Hazard.**  
Using actuator as shaft bearing causes device damage.

Use actuator only to supply rotational torque. Avoid any side loads to actuator output coupling bearings.

To install actuator, proceed as follows:

1. Place actuator over damper shaft; and hold mounting bracket in place. See Fig. 2.
2. Mark screw holes on damper housing.
3. Remove actuator and mounting bracket.
4. Drill or center-punch holes for mounting screws (or use no.10 self-tapping sheet metal screws).
5. Turn damper blades to desired normal (closed) position.
6. Place actuator and mounting bracket back into position and secure bracket to damper box with sheet metal screws.
7. Tighten set screws securely into damper shaft using minimum 100 lb-in., maximum 130 lb-in. torque. Use 1/4 in. wrench (see Specifications for details) to tighten set screws.

## Wiring

See Fig. 3 through 5 for typical wiring diagrams.



### WARNING

**Electrical Power Hazard.**  
Line voltage can cause death or serious injury and short equipment circuitry.

Disconnect power supply before installation.



### CAUTION

**Electrical Shock or Equipment Damage Hazard.**  
Low voltage can shock individuals or short equipment circuitry.

Disconnect power supply before installation.

### IMPORTANT

1. All wiring must comply with local electrical codes, ordinances and regulations.
2. Voltage and frequency of transformer must correspond with the characteristics of power supply and actuator.
3. Use wires rated for at least 75°C (167°F).
4. The conduit fittings are designed for use with 3/8 in. reduced-wall steel or aluminum flexible conduit.

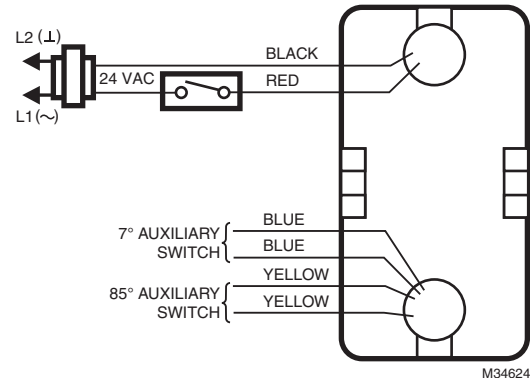

Fig. 3. Typical 24 Vac wiring.

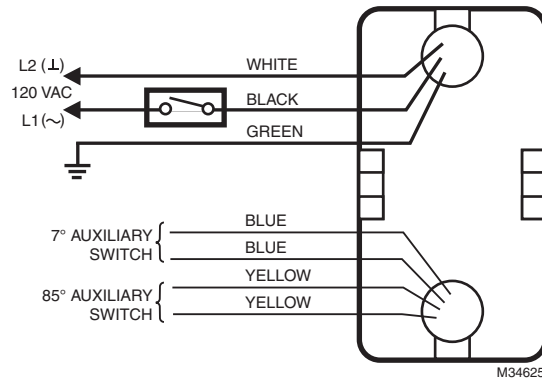

Fig. 4. Typical 120 Vac wiring.

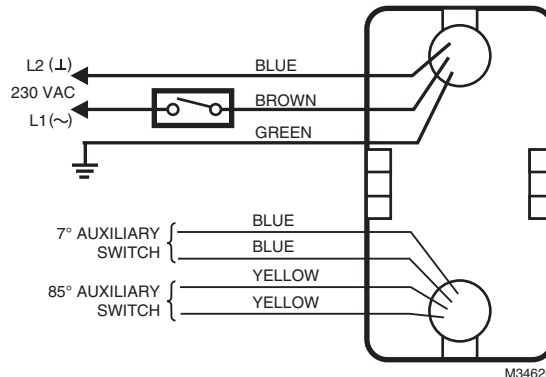

Fig. 5. Typical 230 Vac wiring.

## OPERATION

The MS4104, MS4109, MS4604, MS4609, MS8104 and MS8109 DCA are designed for use in Smoke Control Systems. If power fails, the actuator spring returns to the 0° position. The actuator mounts flush with the damper box. The actuator drives from 0° to 95° and spring returns back to 0°.

The actuators are operated by an spst two-position controller. When using an spst two-position controller, the actuator drives to the damper fully open position when controller contact makes and spring returns to the damper fully closed position when controller contact breaks. The actuator drops to holding power level on detection of stall, independent of hub position.

### Cycling

The actuator and the internal spring are designed so that no special cycling during long-term holding is required. Honeywell recommends following all local, state, and national codes for periodic testing of the entire smoke control system. Refer to National Fire Protection Association (NFPA) National Fire Codes®: NFPA90A, NFPA92A, and NFPA92B for your application.

**NOTE:** The actuator is designed to operate for 30 minutes during a one-time excursion to 350°F (176°C).

## CHECKOUT

### MS4104F, MS4109F (120 Vac model)

1. Check damper position.
2. Connect 120 Vac to the black and white leadwires to drive the damper to the open position. The actuator should drive the damper.
3. If the actuator does not spring return, verify that the actuator is properly installed. See Installation section.
4. If the actuator is correctly installed but neither runs nor spring returns, replace the actuator.

### MS4604F, MS4609F (230 Vac model)

1. Check damper position.
2. Connect 230 Vac to the blue and brown leadwires to drive the damper to the open position. The actuator should drive the damper.
3. If the actuator does not spring return, verify that the actuator is properly installed. See Installation section.
4. If the actuator is correctly installed but neither runs nor spring returns, replace the actuator.

### MS8104F, MS8109F (24 Vac model)

1. Check damper position.
2. Connect 24 Vac to the red and black leadwires to drive the damper to the open position. The actuator should drive the damper.
3. If the actuator does not spring return, verify that the actuator is properly installed. See Installation section.
4. If the actuator is correctly installed but neither runs nor spring returns, replace the actuator.

*National Fire Codes® is a registered trademark of the National Fire Protection Association (NFPA).*



**Automation and Control Solutions**

Honeywell International Inc.

1985 Douglas Drive North

Golden Valley, MN 55422

[customer.honeywell.com](http://customer.honeywell.com)

© U.S. Registered Trademark  
© 2013 Honeywell International Inc.  
63-2740—02 M.S. 05-13  
Printed in Mexico

**Honeywell**