



3900 Dr. Greaves Rd. • Kansas City, MO 64030 • (816) 761-7476 • FAX (816) 765-8955

**INDUSTRIAL SWARTWOUT FIBERGLASS SERIES  
1108 FIBERGLASS CONTROL DAMPER  
"V" Groove Blade**

**STANDARD CONSTRUCTION**

**FRAME**

Vinyl Ester Resin. 8" x 2<sup>3</sup>/<sub>16</sub>" x 1/4" thick (203 x 56 x 6).

**BLADE**

Vinyl Ester Resin, Triple "V" groove 6<sup>5</sup>/<sub>8</sub>" x 5/8" thick (168 x 16).

**AXLES**

3/4" (19) diameter fiberglass rod.

**BEARINGS**

Molded PTFE.

**LINKAGE**

316 stainless steel out of airstream.

**MAXIMUM TEMPERATURE**

200°F (94°C).

**MINIMUM SIZE**

Single blade, parallel action 8"w x 8"h (203 x 203).

Two blades, parallel or opposed action 8"w x 12"h (203 x 305).

**MAXIMUM SIZE**

Single section 48"w x 72"h (1219 x 1829).

Multi-section unlimited.

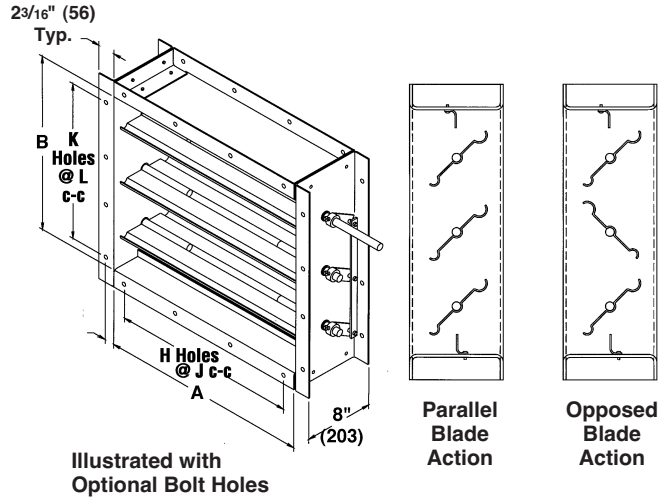

Dimensions in parenthesis ( ) indicate millimeters.

**PRESSURE LIMITATIONS**

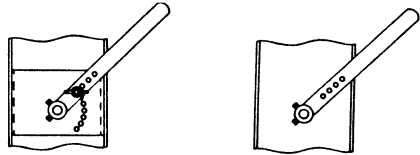

**HAND QUADRANT (HQ)**  
(optional)

**CRANK LEVER (CL)**  
(optional)

| DAMPER WIDTH | MAXIMUM SYSTEM PRESSURE | MAXIMUM SYSTEM VELOCITY | LEAKAGE WITHOUT SEALS |                   |
|--------------|-------------------------|-------------------------|-----------------------|-------------------|
|              |                         |                         | % OF MAX. FLOW        | CFM/SQ. FT.       |
| 48" (1219)   | 2.5" w.g.               | 2000 fpm                | 1.60                  | 32 (.91 m³/min.)  |
| 36" (914)    | 5.5" w.g.               | 2000 fpm                | 1.60                  | 32 (.91 m³/min.)  |
| 24" (610)    | 10" w.g.                | 2000 fpm                | 2.00                  | 40 (1.13 m³/min.) |
| 12" (305)    | 20" w.g.                | 2000 fpm                | 3.00                  | 60 (1.70 m³/min.) |

| FRAME   | BLADES                | SEALS (Optional)          | AXLES                               | BEARINGS    | LINKAGE   | ACCESSORIES (Optional)                                |
|---|-----------------------|---------------------------|-------------------------------------|-------------|---|---|
| 8" x 2 <sup>3</sup> / <sub>16</sub> " x 1/4" (203 x 56 x 6) Channel | 6 5/8" (168) V Groove | Viton Blade Seal          | 3/4" (19) diameter Fiberglass Axles | Molded PTFE | 316 STN. STL. Side Linkage                            | Bolt Holes<br>One (1) Flange<br>Both (2) Flanges      |
|   |                       | Neoprene Blade Seal       |                                     |             | Vinyl Ester Resin Face Linkage (Parallel Action Only) | Manual Actuator<br>Crank Lever (CL)<br>Hand Quad (HQ) |
|   |                       | Polycarbonate Jamb Seal   |                                     |             |   | Actuators<br>Electric<br>Pneumatic                    |
|   |                       | Stainless Steel Jamb Seal |                                     |             |   |   |
|   |                       | Integral Shaft Seals      |                                     |             |   |   |

| QTY. | BLADE ACTION |    | DIMENSIONS |   |   |   |   |   |   | VARIATIONS | TAG |   |
|------|--------------|----|------------|---|---|---|---|---|---|------------|-----|---|
|      | PB           | OB | A          | B | G | H | J | K | L |            |     | M |
|      |              |    |            |   |   |   |   |   |   |            |     |   |
|      |              |    |            |   |   |   |   |   |   |            |     |   |
|      |              |    |            |   |   |   |   |   |   |            |     |   |
|      |              |    |            |   |   |   |   |   |   |            |     |   |
|      |              |    |            |   |   |   |   |   |   |            |     |   |
|      |              |    |            |   |   |   |   |   |   |            |     |   |

**PROJECT:**  
**ARCH/ENGR:**  
**REPRESENTATIVE:**

**LOCATION:**