



34-636-2472, Rev. C

(barcode for factory use only)

M9300 Series Switch Kits

Installation Instructions

M9300-1, M9300-2

Part No. 34-636-2472, Rev. C

Issued June 2017

Refer to the [QuickLIT website](#) for the most up-to-date version of this document.

Application Requirements

IMPORTANT: Use this M9300 Series Switch Kit only to control equipment under normal operating conditions. Where failure or malfunction of the electric actuator could lead to personal injury or property damage to the controlled equipment or other property, additional precautions must be designed into the control system. Incorporate and maintain other devices, such as supervisory or alarm systems or safety or limit controls, intended to warn of or protect against failure or malfunction of the electric actuator and switch kit.

IMPORTANT : Utiliser ce kit commutateur série M9300 uniquement pour commander des équipements dans des conditions normales de fonctionnement. Lorsqu'une défaillance ou un dysfonctionnement du servomoteur électrique risque de provoquer des blessures ou d'endommager l'équipement contrôlé ou un autre équipement, la conception du système de contrôle doit intégrer des dispositifs de protection supplémentaires. Veiller dans ce cas à intégrer de façon permanente d'autres dispositifs, tels que des systèmes de supervision ou d'alarme, ou des dispositifs de sécurité ou de limitation, ayant une fonction d'avertissement ou de protection en cas de défaillance ou de dysfonctionnement du servomoteur électrique et du kit commutateur.

Installation

Parts Included

Figure 1: Switch Kit, Conduit Adaptor, Plastic Pointer, and Switch Kit Extender

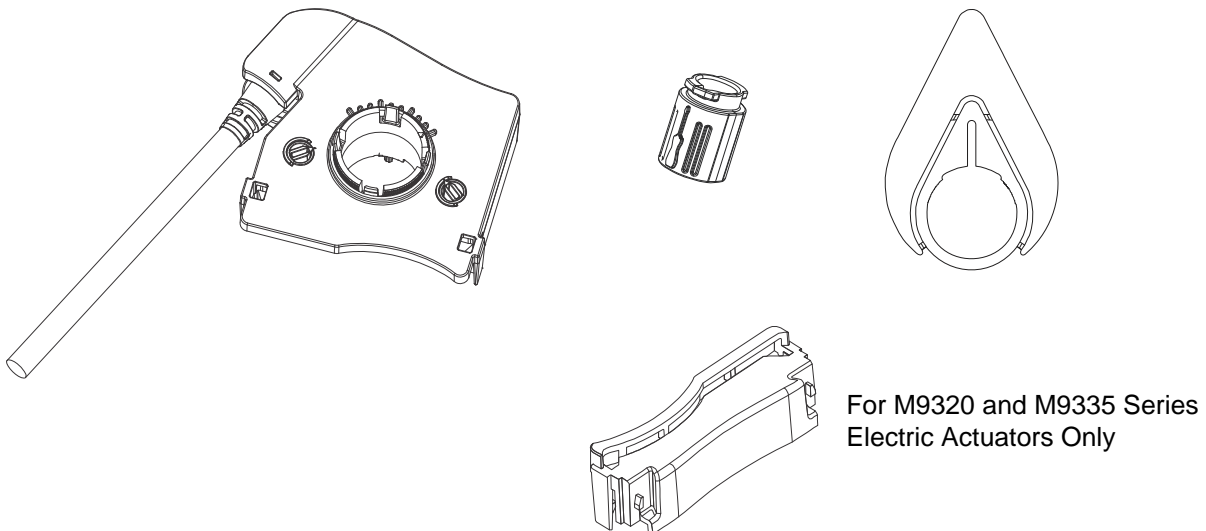

Tool Needed

You will need a flat-blade screwdriver (not included).

Mounting the Switch Kit to the M9300 Series and VA9300 Series Electric Actuators

1. Be sure that the electric actuator is installed correctly.
2. Press the manual override on the electric actuator (1). (Figure 2)
3. Rotate the electric actuator and the switch kit fully counterclockwise (CCW) (2). (Figure 2 and Figure 3)
4. For M9320 and M9335 Series Electric Actuators only, install the switch kit extender and then the switch kit. (Figure 4)
5. For all other M9300 Series and VA9300 Series Electric Actuators, snap the switch kit (3) onto the electric actuator (4), making sure that the posts align with the adjacent holes (5). (Figure 5)
6. Slide the conduit adaptor (1) over the cable (2) into the switch kit (3), and turn the conduit adaptor clockwise (CW) to lock the conduit adaptor into the switch kit. (Figure 6)
7. Press down (1) and rotate the cam (2) to the desired switch setting, then release. (Figure 7)

Note: Use a manual screwdriver to adjust the cam. An electric screwdriver causes excess torque, which could damage the switch cam.

8. Snap the plastic pointer onto the switch kit. (Figure 8)
9. Wire the switch kit. (Figure 9)

Figure 2: Pressing the Manual Override and Rotating the Electric Actuator

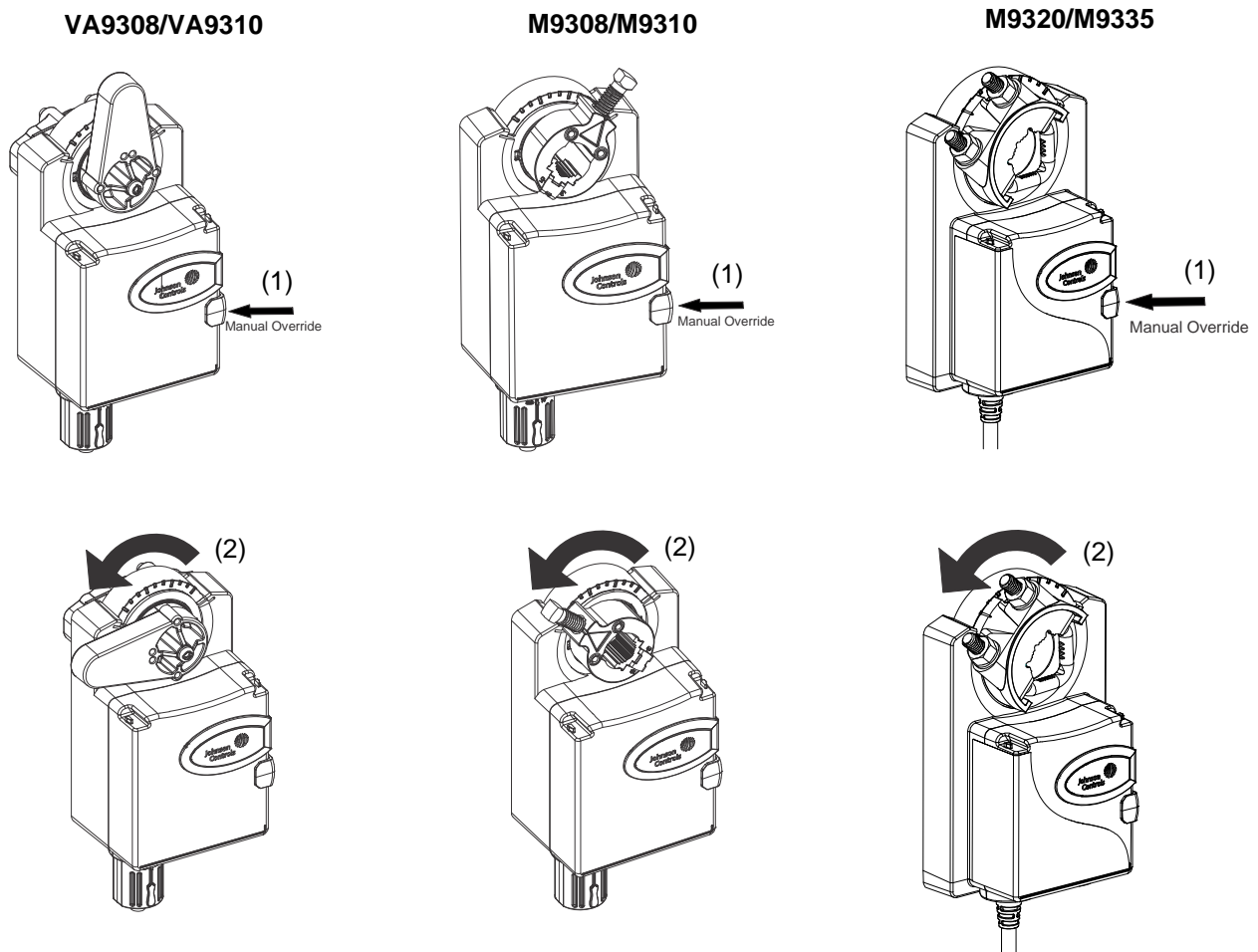

Figure 3: Rotating the Switch Kit Fully CCW

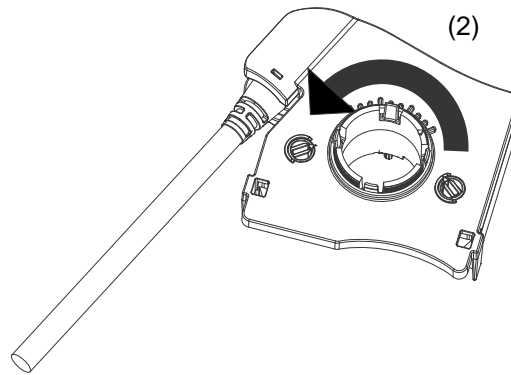

Figure 4: Installing the Switch Kit Extender and Switch Kit to an M9320 or M9335 Series Electric Actuator

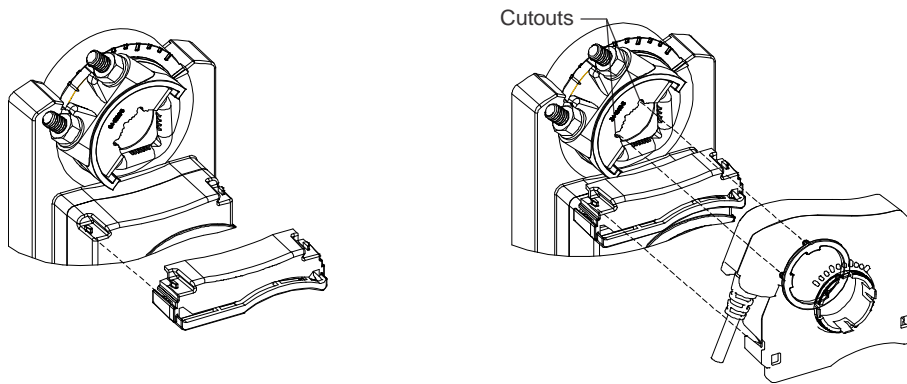

Figure 5: Attaching the Switch Kit to the Electric Actuator

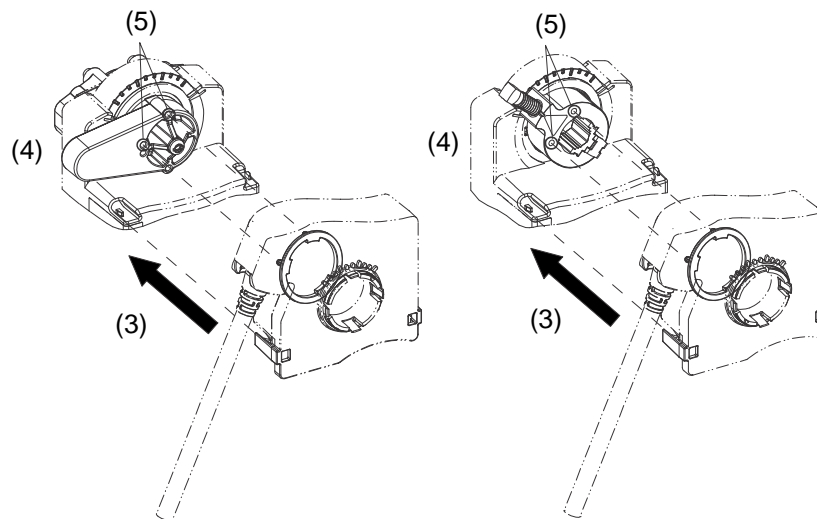

Figure 6: Securing the Conduit Adaptor to the Switch Kit

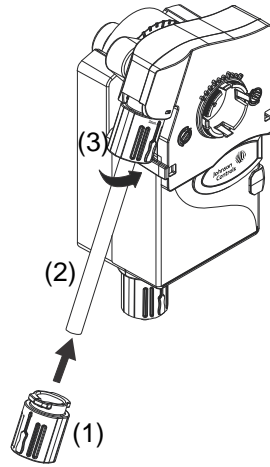

Figure 7: Adjusting the Dials for the Switch Kit

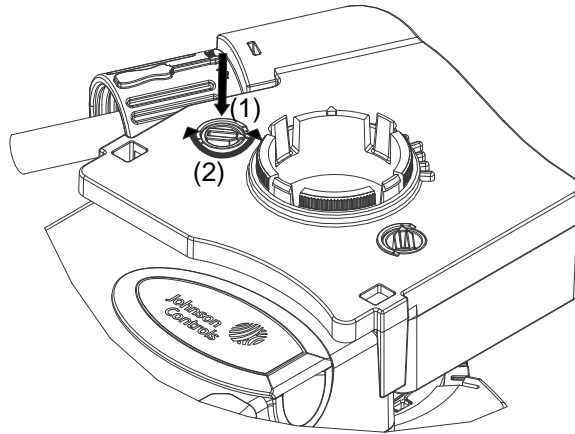

Figure 8: Attaching the Plastic Pointer

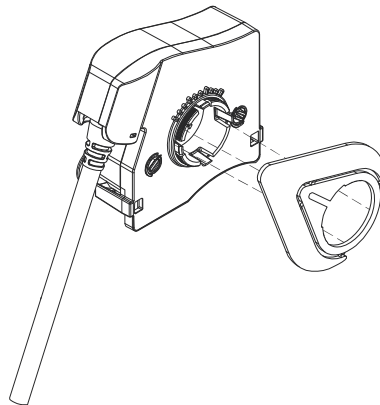
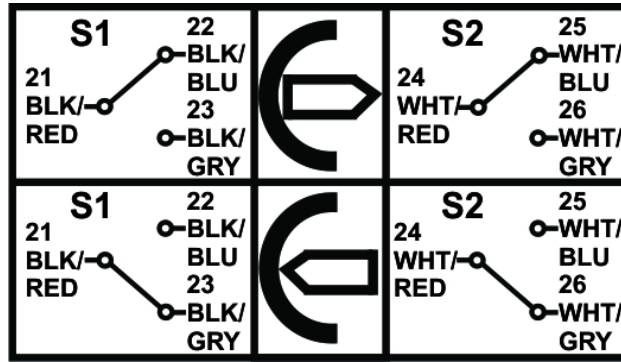

Figure 9: Wiring Diagrams



Removing the Switch Kit and Conduit Adaptor (Figure 10)

1. Place a screwdriver underneath the tab on each side of the actuator (1) and pull back the tab (2).
2. Remove the switch kit (3) from the actuator in the direction of the output axis (4).
3. To remove the conduit adaptor, insert a screwdriver into the slot (5) and turn the conduit adaptor counterclockwise (6) to unlock it.

Figure 10: Removing the Switch Kit and Conduit Adaptor

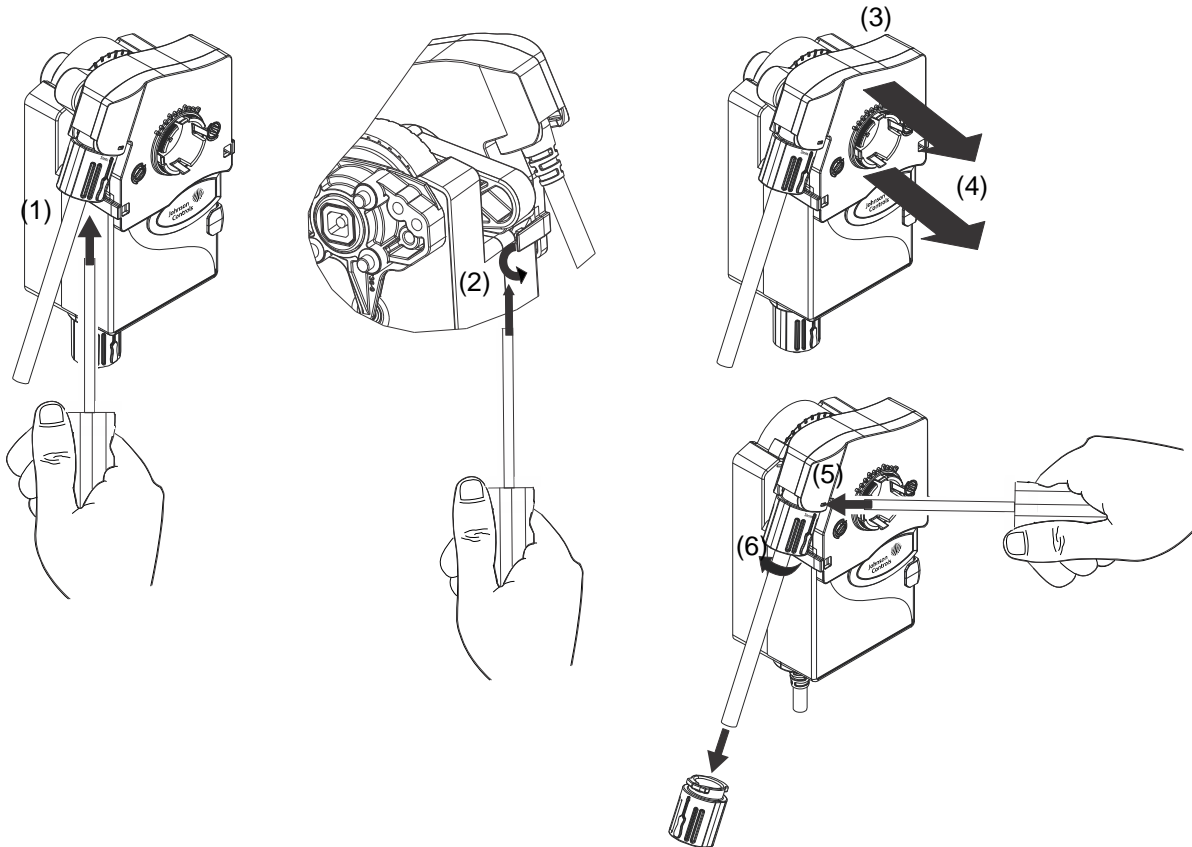

Technical Specifications

M9300 Series Switch Kits

Product Description	M9300-1 Switch Kit with one single-pole, double-throw (SPDT) switch	M9300-2 Switch Kit with two SPDT switches
Switch Rating	3(0.5) A, 240 VAC	
Electrical Connection	55 in. (1.4 m) halogen-free cable with three 18 AWG (0.82 mm ²) conductors and 1/4 in. (6 mm) ferrule ends	55 in. (1.4 m) halogen-free cable with six 18 AWG (0.82 mm ²) conductors and 1/4 in. (6 mm) ferrule ends
Ambient Conditions	Operating: -22 to 140°F (-30 to 60°C), 95% RH, noncondensing Storage: -40 to 185 °F (-40 to 85°C), 95% RH, noncondensing	
Enclosure	NEMA 5/IP54	
Compliance	United States: UL Listed, CCN XAPX, File E27734; to UL 60730-1: Automatic Electrical Controls for Household and Similar Use, Part 1; and UL 60730-2-14: Part 2, Particular Requirements for Electric Actuators. Plenum Rated (UL 2043). Suitable for use in Other Environmental Air Space (Plenum) in accordance with section 300.22 (c) of the National Electrical Code.	
	Canada: UL Listed, CCN XAPX7, File E27734; to CAN/CSA E60730-1:02: Automatic Electrical Controls for Household and Similar Use, Part 1; and CAN/CSA-E60730-2-14, Particular Requirements for Electric Actuators.	
CE	Europe: CE Mark—Johnson Controls declares that this product is in compliance with the essential requirements and other relevant provisions of the Low Voltage Directive. IEC 60730-1: Automatic Electrical Controls for Household and Similar Use, Part 1: General Requirements and IEC 60730-2-14, Automatic Electrical Controls for Household and Similar Use; Part 2—Particular Requirements for Electric Actuators	
	Australia and New Zealand: RCM Mark, Australia/NZ Emissions Compliant	

The performance specifications are nominal and conform to acceptable industry standards. For application at conditions beyond these specifications, consult the local Johnson Controls office. Johnson Controls shall not be liable for damages resulting from misapplication or misuse of its products.

European Single Point of Contact:

JOHNSON CONTROLS
WESTENDHOF 3
45143 ESSEN
GERMANY

NA/SA Single Point of Contact:

JOHNSON CONTROLS
507 E MICHIGAN ST
MILWAUKEE WI 53202
USA

APAC Single Point of Contact:

JOHNSON CONTROLS
C/O CONTROLS PRODUCT MANAGEMENT
NO. 22 BLOCK D NEW DISTRICT
WUXI JIANGSU PROVINCE 214142
CHINA



Building Technologies & Solutions
507 E. Michigan Street, Milwaukee, WI 53202

Metasys® and Johnson Controls® are registered trademarks of Johnson Controls. All other marks herein are the marks of their respective owners. © 2017 Johnson Controls.

M9300 Series Switch Kits Installation Instructions