

ALTERNATE SUBSTRATES ANCHORS

1. FOR ALL SUBSTRATES ANCHORS SHALL MAINTAIN SAME END DISTANCE AND SPACING AS SHOWN ON DETAILS.
2. FOR WOOD USE ANCHORS AS DETAILED.
3. FOR STEEL USE #10 -16 X 1-1/2" LG GRADE 2.5 D.
4. FOR CONCRETE AND FILLED CMU USE 1/4" TAPCON WITH MIN 1-1/2" EMBED AND 2" EDGE DISTANCE.

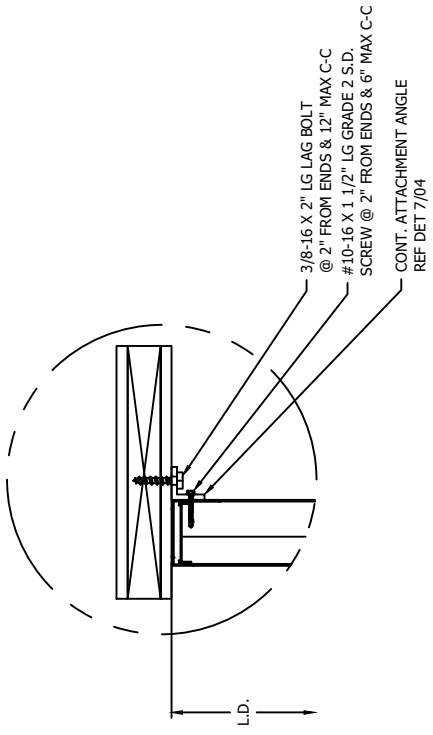

2 LOUVER HEAD ATTACHMENT DETAIL
02 N.T.S.

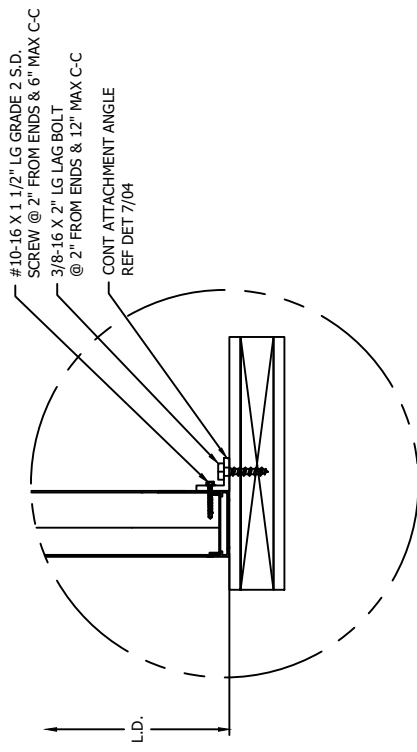

4 LOUVER SILL ATTACHMENT DETAIL
02 N.T.S.

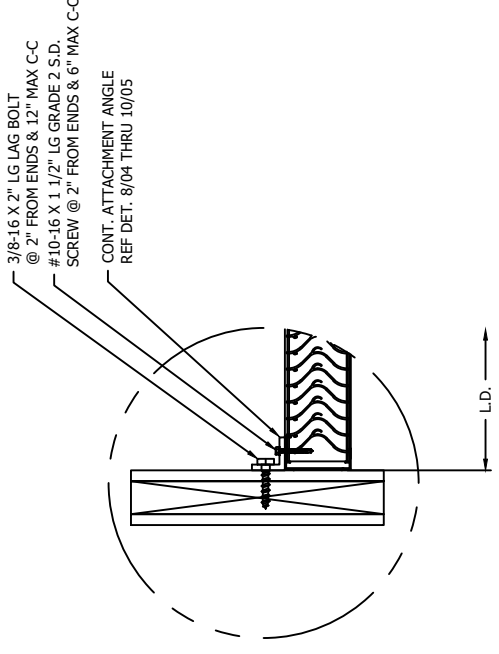

3 LOUVER JAMB ATTACHMENT DETAIL
02 N.T.S.

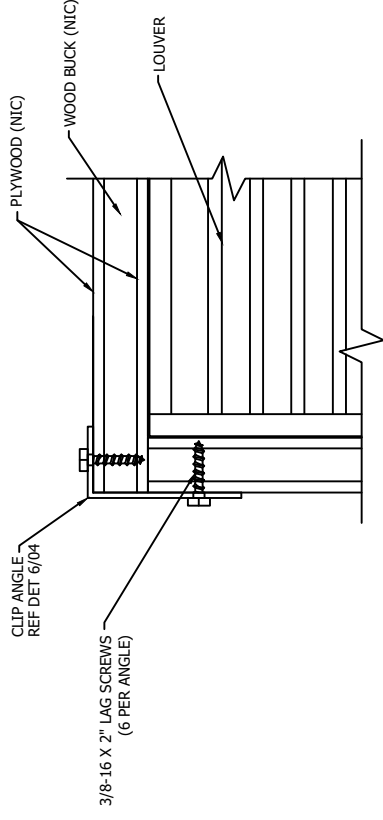

5 WOOD BUCK DETAIL
02 N.T.S.

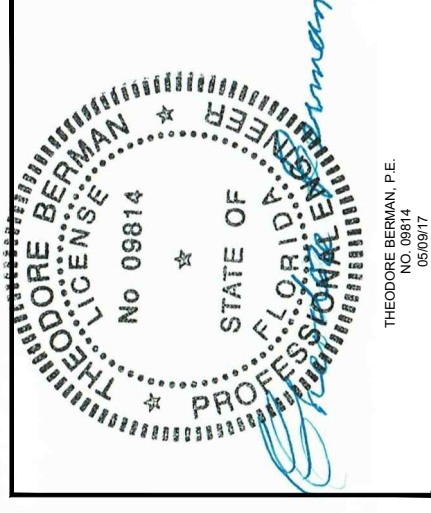

THEODORE BERMAN, P.E.
NO. 09814
05/09/17

RELEASE



3900 DR. GREAVES RD
GRANDVIEW, MO 64030

Ted Berman and Associates, LLC
Certificate of Authorization # 27502
925 Arthur Godfrey Rd. Suite 104
Miami Beach, FL 33140
(305) 868-4707
www.flproductapproval.com

(P/Quick Draw)

ISSN	CJD	DATE	10/04/16
CHKD	JSR	DATE	10/15/16
APPRD	MMM	DATE	10/05/16
BY			
SALES PERSON			
PREP MAN/AL			
BY			
TITLE			
EMERGENCY DETAILS			
SHEET	3	OF	5
DRAWN			

2331108-03

MANUFACTURING NOTE:

NOTE THAT ALL INSTALLATION ANGLES MUST BE PRE-PUNCHED BEFORE SHIPPING FROM PLANT.

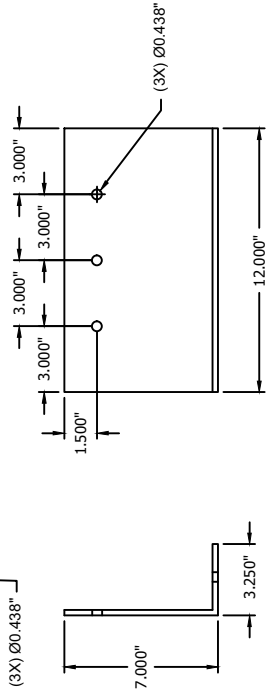
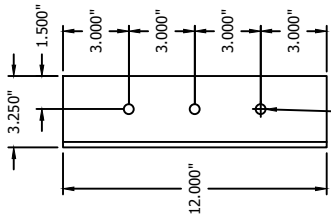

6 CLIP ANGLE FOR WOOD STRUCTURE DETAIL

03 N.T.S.
MATEL: 1/4" THK ALUMINUM ANGLES
QTY: 6

7 HEAD & SILL ANGLE DETAIL

03 N.T.S.
MATEL: 1/4" EXTRUDED ALUMINUM
QTY: 6

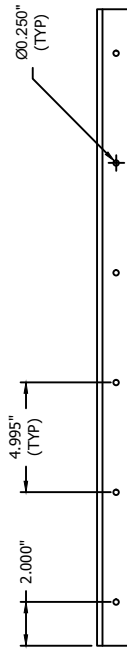
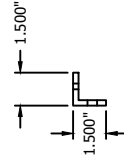
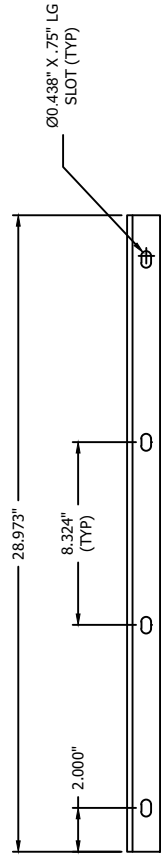
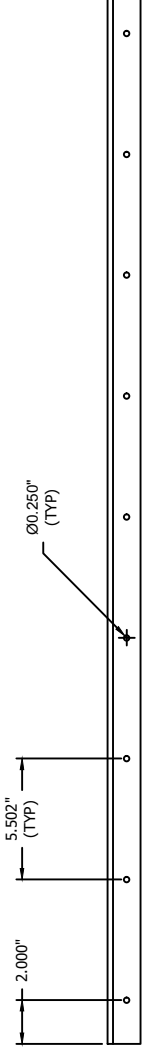
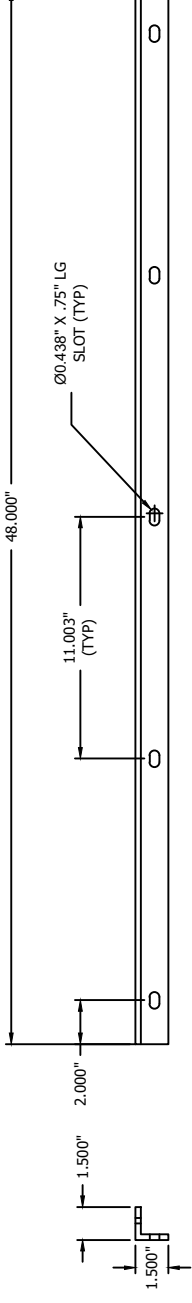

8 ASSEMBLY "A" JAMB ANGLE DETAIL

03 N.T.S.
MATEL: 1/4" EXTRUDED ALUMINUM
QTY: 2

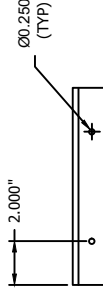
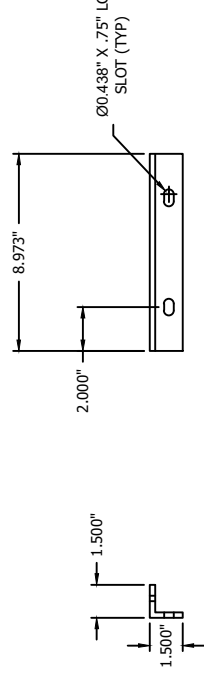

9 ASSEMBLY "B" JAMB ANGLE DETAIL

03 N.T.S.
MATEL: 1/4" EXTRUDED ALUMINUM
QTY: 2

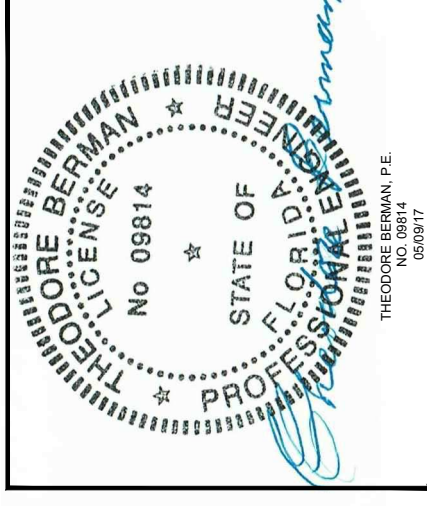

THEODORE BERMAN, P.E.
NO. 09814
05/09/17

RELEASE



3900 DR. GREAVES RD
GRANDVIEW, MO 64030

Ted Berman and Associates, LLC
Certificate of Authorization # 27502
925 Arthur Godfrey Rd, Suite 104
Miami Beach, FL 33140
(305) 868-4707
www.flproductapproval.com

(PI Quick Draw)

ISSN BY: CID	DATE: 10/04/16
ISSN BY: JSR	DATE: 10/15/16
APPROV. BY: MMM	DATE: 10/05/16
ISSN BY: [blank]	DATE: [blank]
SALES PERSON: [blank]	DATE: [blank]
PREP MAN: [blank]	DATE: [blank]
TITLE: EME3625DFL DETAILS	
SHEET: 4	OF: 5
TWEEK: [blank]	

2331108-04

CHANGE LETTER	REVISION DESCRIPTION
DATE	APPRD. BY
DATE	CHKD. BY
DATE	DR.

