



## FSDR60M COMBINATION FIRE SMOKE DAMPER

UL555 and UL555S Leakage Class 1 Classified  
FOR USE IN DYNAMIC AND STATIC SYSTEMS

### APPLICATION

The FSDR60M is a "true round" Class 1 leakage rated combination fire and smoke damper designed for use in metal, wood or concrete fire and smoke rated partitions and concrete floors. The FSDRM60 is equipped with a 24 volt modulating actuator for volume control in round duct. The damper is rated for maximum velocity of 3,000 fpm and 4" (102) static pressure. The integral frame and unique "cinch plate" design provide a low cost, easy to install, high performing damper. The damper is rated for maximum velocity of 4,000 fpm (20.3 m/s) and 4" (1 kPa) static pressure. The integral frame and unique "cinch plate" design provide a low cost, easy to install, high per-forming damper.

STANDARD CONSTRUCTION	
Description	FSDR60
Frame/Sleeve	20 gauge (.9) galvanized steel, standard 17" (432) long. Frame/sleeves available up to 36" (914) in length.
Blades	Two-piece 14 gauge (1.9) equivalent thickness galvanized steel.
Bearings	Stainless steel sleeve type, pressed into frame.
Axle	1/2" (12) diameter plated steel.
Blades	Silicone edge type sandwiched between two piece blade. Full circumference smoke seal to 450°F (232°C).

### CONTROLLED CLOSURE DEVICE (HEAT-ACTUATED)

EFL (Electric Fuse Link) – 165°F (74°C) standard. 212°F (100°C), 250°F (121°C), or 350°F (177°C) are options.  
PFL (Pneumatic Fuse Link) – 165°F (74°C) standard. 212°F (100°C) or 285°F (141°C) are options.

### DAMPER SIZES

#### MINIMUM SIZE

6" diameter (152).

#### MAXIMUM SIZE

Vertical / Horizontal Installation – 24" diameter (610).  
See page 2 for dimensional information.

### OPTIONS

- **ADC105** Addressable monitoring and test relay for Simplex ES fire alarm system.
- **DTS** (Damper test Switch) test switch for cycle testing.
- **TS150 FireStat** for reopenable operation in dynamic smoke management systems.
- **DSDF** Flow Duct Smoke Detector – Consult Ruskin.
- **SP100 Switch Package** to remotely indicate damper blade position.
- **Sleeve/Frame** of various lengths to insure field compliance with UL installation requirements.
- **MCP** control panels for test purposes or smoke management systems.

### NOTES

1. Units furnished approximately 1/8" (3) smaller than given size.
2. Dimensions shown in parentheses ( ) indicate millimeters.

MAXIMUM OPERATIONAL RATINGS	
Description	FSDR60M
UL555S Leakage Rating	Class I
UL555 Hourly Rating	1 1/2 Hour
Maximum Velocity	4000 FPM (20.3 m/s)
Maximum Pressure	4 in. wg (1kPa)
Temperature	350°F (177°C)

Model **FSDR60M** meets the requirements for fire, smoke and combination fire/smoke dampers established by:

- **National Fire Protection Association** NFPA Standards 80, 90A, 92A, 92B, 101 and 105
- **ICC International Building Codes**
- **CSFM California State Fire Marshal** Fire Damper Listing (#3225-245:107) and Smoke Damper Listing (#3230-245:108)
- **New York City** (BSA Listing #176-82-SM)

### UL CLASSIFIED

UL555 Listing R5531, UL555S Listing R5531



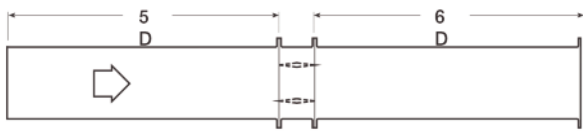
# PERFORMANCE DATA FOR FSDR60M

This pressure drop testing was conducted in accordance with AMCA Standard 500-D using the three configurations shown. All data has been corrected to represent standard air at a density of .075 lb/ft<sup>3</sup>(1.201 kg/m<sup>3</sup>).

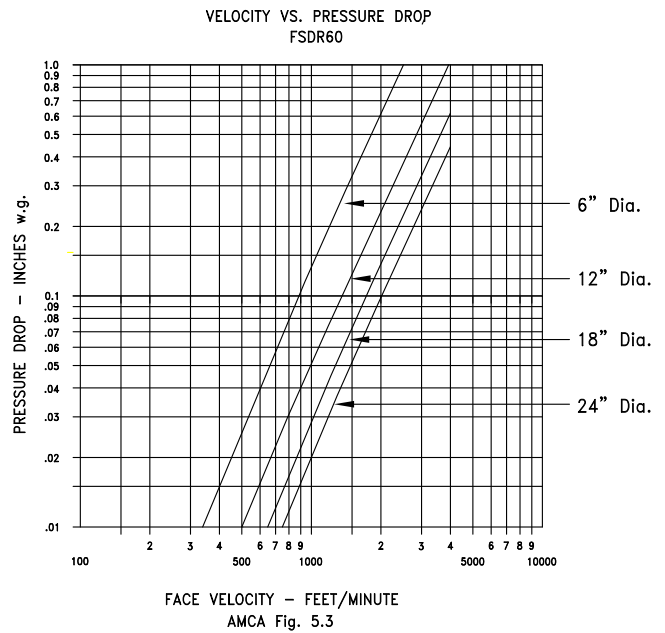
Actual pressure drop found in any HVAC system is a combination of many factors. This pressure drop information along with an analysis of other system influences should be used to estimate actual pressure losses for a damper installed in a given HVAC system.

## AMCA Test Figure

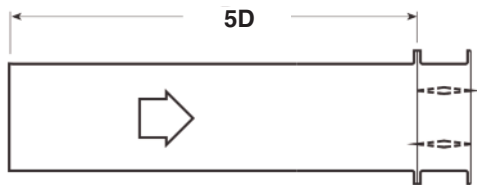
**Figure 5.3** Illustrates a fully ducted damper. This configuration has the lowest pressure drop of the three test configurations because entrance and exit losses are minimized by straight duct runs upstream and downstream of the damper.



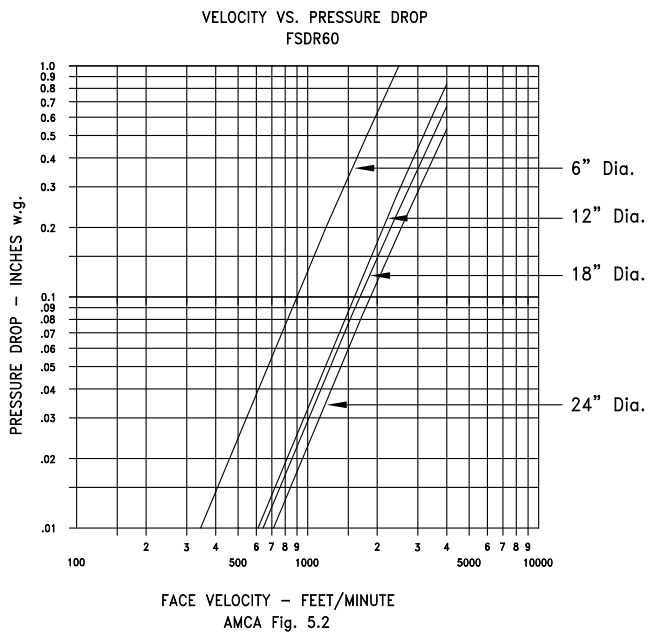
**Figure 5.3**



**Figure 5.2** Illustrates a ducted damper exhausting air into an open area. This configuration has a lower pressure drop than Figure 5.5 because entrance losses are minimized by a straight duct run upstream of the damper.

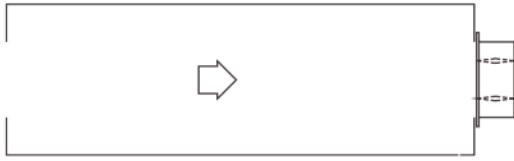


**Figure 5.2**

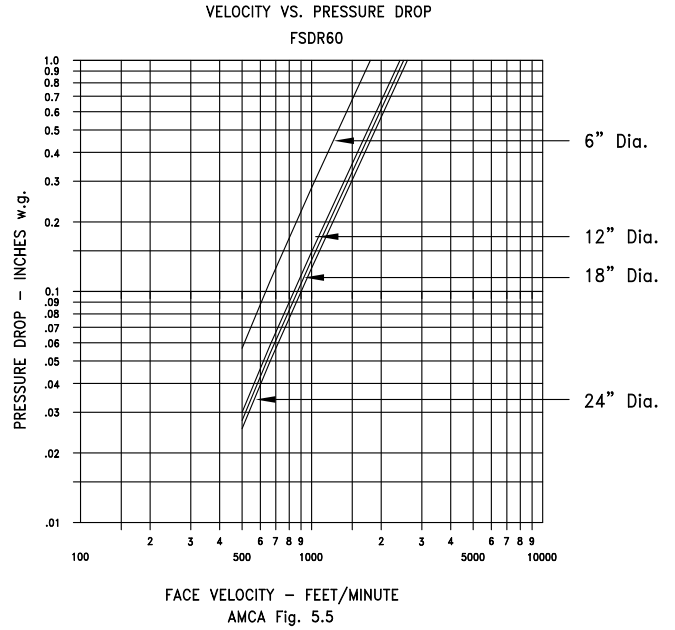


# PERFORMANCE DATA FOR **FSDR60M**

**Figure 5.5** illustrates a plenum mounted damper. This configuration has the highest pressure drop because of extremely high entrance and exit losses due to the sudden changes of area in the system.

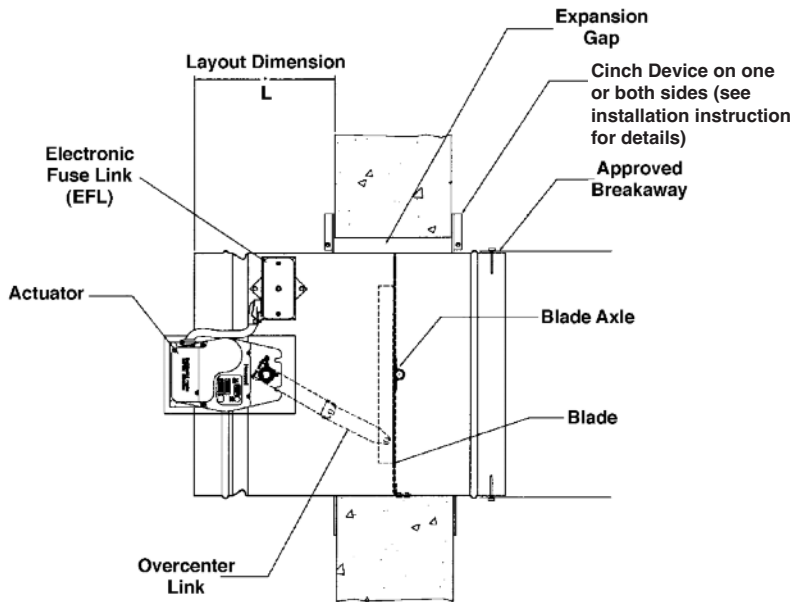


**Figure 5.5**

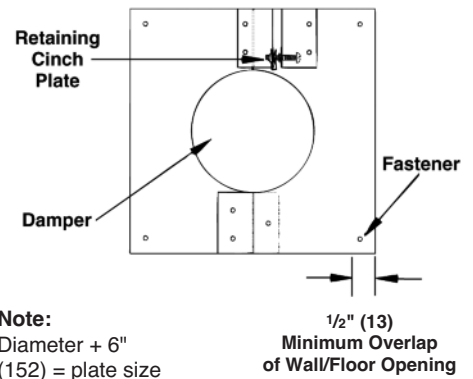


## GENERAL INSTALLATION INFORMATION

### METAL/WOOD/MASONRY WALL OR CONCRETE FLOOR INSTALLATION

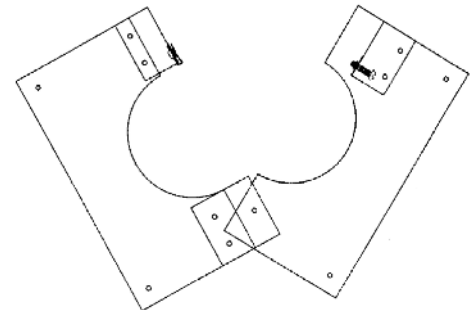


### RETAINING "CINCH" PLATE



A **square** opening in wood or metal stud walls or masonry walls and floors shall be a minimum of 1" (25) and a maximum of 2 1/2" (64) larger than the damper diameter. See wood stud and metal stud framing for fire dampers installation instructions supplement for complete framing details. A **round** opening in masonry walls or floors shall be a minimum of 1" (25) and a maximum of 2 1/2" (64) larger than the damper diameter.

Factory supplied retaining "cinch" plates hold the damper within the wall opening. The plates must overlap the opening a minimum of 1/2" (13). The plate fits snugly around the integral sleeve. The plates are fastened directly to the wall or floor.



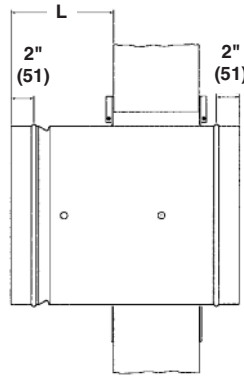
**REFER TO THE FSDR60 INSTALLATION INSTRUCTIONS FOR COMPLETE INSTALLATION DETAILS.**

## DIMENSIONAL INFORMATION

### MINIMUM SLEEVE LENGTH

Wall/Floor Thickness	Min. Sleeve Length
4" (102)	17" (432)
5" (127)	17" (432)
6" (152)	20" (508)
7" (178)	20" (508)
8" (203)	20" (508)
9" (229)	22" (559)
10" (254)	22" (559)
11" (279)	23" (584)
12" (305)	24" (610)
Over 12" (305) Thru 24" (609)	Add 1" (25) for every inch of wall/floor depth

Note: 36" (914) maximum sleeve length.



The "L" dimension is the dimension the sleeve, on the actuator side of the damper, can extend beyond the wall or floor in a standard installation. The "L" dimension is designed to provide the installer with information to make installation easier. The table below provides a range for the "L" dimension.

### "L" DIMENSIONS

	WALL THICKNESS						
	4" (102)	5" (127)	6" (152)	7" (178)	8" (203)	9" (229)	10" (254)
Minimum	8 1/4"	8 1/4"	8 1/4"	8 1/4"	8 1/4"	8 1/4"	8 1/4"
Standard	9"	9"	9"	9"	9"	9"	9"
Maximum	10"	10"	10"	10"	10"	10"	10"

**NOTE:** The 2" (51) dimension is for duct connections. The "L" dimension includes the 2" (51) for duct connection.

## SUGGESTED SPECIFICATION

Combination fire smoke dampers meeting or exceeding the following specifications shall be furnished and installed at locations shown on plans or as described in schedules. Combination fire smoke dampers shall be produced in an ISO 9001 certified factory and shall be warranted to be free from defects in material and workmanship for a period of 5 years after date of shipment. Dampers shall meet the requirements of NFPA80, 90A, 92A and 92B and shall have a fire rating of 1 1/2 hours in accordance with the latest edition of UL555 and shall be classified as Leakage Class I Smoke Dampers in accordance with the latest version of UL555S. The leakage rating under UL555S shall be leakage Class 1 (8 cfm/sq. ft. at 4" w.g.).

Damper frames shall be a minimum of 20 (.9) gauge steel and the blade shall be two piece, equivalent to 14 (1.9) gauge steel. Bearings shall be self-lubricating stainless steel sleeve turning in an extruded hole in the frame. (Bronze bearings shall not be acceptable). Blade seals shall be silicone edge designed to withstand 450°F (232°C) mechanically fastened and fully encompassing blade edge. Damper must have an integral 20 (.9) gauge sleeve and 20 (.9) gauge retaining plate for damper mounting. Square to round transitions are unacceptable.

Combination fire smoke dampers and their actuators shall be qualified in accordance with UL555S to an elevated temperature of 50°F (121°C) or 350°F (177°C) depending upon the actuator. Appropriate electric or pneumatic actuators (specifier select one) shall be installed by the damper manufacturer at time of damper fabrication. Electric actuators, factory installed on dampers, shall have been tested for prolonged periods of holding (minimum 1 year) with no evidence of reduced spring return performance. Each damper shall be rated for leakage and airflow in either direction through the damper.

Dampers shall be Ruskin model **FSDR60M**.

(Consult [www.ruskin.com](http://www.ruskin.com) for electronic version of this "Quick" spec as well as for complete 3-part CSI MasterFormat Specifications)



3900 Dr. Greaves Rd.  
Kansas City, MO 64030  
(816) 761-7476  
FAX (816) 765-8955  
[www.ruskin.com](http://www.ruskin.com)