

IBD2G, IBD2SSG, DIBD2G, DIBD2SSG AND IBDTG CURTAIN TYPE FIRE DAMPERS FOR GRILLES

1 1/2 HOUR UL555 RATED**FOR USE IN STATIC OR DYNAMIC SYSTEMS**

APPLICATION

IBD2G, IBD2SSG (Static) and DIBD2G, DIBD2SSG (Dynamic) curtain type fire dampers for grille installation may be installed vertically in walls or horizontally in floors with fire resistance ratings of less than 3 hours. Model 'G' curtain fire dampers are offset in a sleeve to fit within the wall/floor plane behind the customer's supplied grille. The damper/sleeve assembly is installed with angle one side (FAST) to allow the use of all types of grilles.

Model 'G' dampers require access to both sides of the wall/floor for the proper installation; however, access through the grille for inspection or maintenance is permissible.

For application where the damper would be installed outside the plane of the wall or floor refer to model GA (Grille Access) or OW (Out of Wall).

STANDARD CONSTRUCTION

FRAME AND BLADES

Galvanized or stainless steel (in gauges required by UL listing R-5531).

CLOSURE SPRINGS

Stainless steel (when required by UL listing R-5531).

FUSIBLE LINK

165°F (74°C) is standard. 212°F (100°C) is available for all models. 285°F (141°C) available on galvanized steel models.

SLEEVE

20 gauge (1.0) galvanized or stainless steel.

MOUNTING ANGLE (FAST)

20 gauge (1.0) galvanized steel (one piece wrap around angle).

OPTIONS

- **FM Approved** as Specification Tested Product.
- **SP200 Switch Package** to remotely indicate damper blade position.
- **Sleeve** of various lengths and gauges to insure field compliance with UL installation requirements.
- **316 Stainless Steel** constructions.

NOTES

1. Dimensions shown in parentheses () indicate millimeters.
2. Damper/sleeve assembly furnished actual size.

The (D)IBD2G meets the requirements for fire dampers established by:

- **National Fire Protection Association NFPA Standards** 90A and 101
- **ICC International Building Codes**
- **CSFM California State Fire Marshal Fire Damper Listing** (#3225-0245:005)
- **New York City** (MEA Listing #450-06-M)

UL CLASSIFIED

UL555 Listing R5531



SEE COMPLETE
MARKING
ON PRODUCT



SPECIFICATION
TESTED PRODUCT
(OPTION)

DAMPER SIZES

IBD2G and IBD2SSG

Not for use in Dynamic (fans on) System

MINIMUM SIZE

Vertical Installation – 4" w x 4" h (102 x 102)

Horizontal Installation – 6" w x 6" h (152 x 152)

MAXIMUM SIZE

Vertical Installation – 90" w x 48" h (2286 x 1219) or 48" w x 72" h (1219 x 1829)

Horizontal Installation – 90" w x 48" h (2286 x 1219) or 48" w x 90" h (1219 x 2286)

DIBD2G

For use in Dynamic (fans on) or Static (fans off) System

MINIMUM SIZE

Vertical – 4" w x 4" h (102 x 102)

Horizontal Installation – 6" w x 6" h (152 x 152)

MAXIMUM SIZE

Vertical Installation – 72" w x 48" h (1829 x 1219) or 48" w x 72" h (1219 x 1829) or 90" w x 24" h (2286 x 610)

Horizontal Installation – 36" w x 48" h (914 x 1219) or 48" w x 36" h (1219 x 914)

DIBD2SSG

For use in Dynamic (fans on) or Static (fans off) System

MINIMUM SIZE

Vertical – 4" w x 4" h (102 x 102)

Horizontal Installation – 6" w x 6" h (152 x 152)

MAXIMUM SIZE

Vertical Installation – 72" w x 48" h (1829 x 1219) or 48" w x 72" h (1219 x 1829) or 90" w x 24" h (2286 x 610)

Horizontal Installation – 24" w x 24" h (610 x 610)

IBDT

Not for use in Dynamic (fans on) System

MINIMUM SIZE

Vertical or Horizontal Installation – 4" w x 4" h (102 x 102)

MAXIMUM SIZE

Vertical Installation – 40" w x 48" h (1016 x 1219)

Horizontal Installation – 60" w x 12" h (1524 x 305)

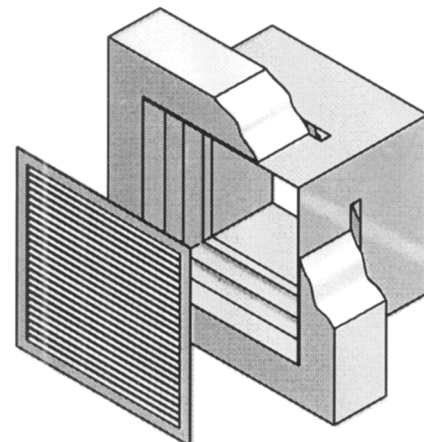

HOW TO APPLY IBD2G, IBD2SSG, DIBD2G, DIBD2SSG, AND IBDTG

DIRECTIONS

1. Size the damper A x B (width x height)
2. Determine the application: Ducted or Transfer Opening.
3. 'S' dimension is the damper set back dimension to allow for different grille depths.
4. Calculate sleeve length (L).
5. Determine the orientation (wall, floor, or ceiling)
6. Determine the wall, floor, or ceiling depth.

DUCTED

1. 'G' models have a standard 'S' set back dimension of 2" (51). Other set back dimensions are available.
2. Sleeve lengths are calculated as:
'S' dimension plus 6" (152).
Example: $S = 2" (2" + 6" = 8" [51 + 152 = 203])$
Sleeve length = 8" (203)
Minimum wall, floor or ceiling depth = 4" (102)
3. The minimum wall, floor or ceiling depth is calculated by adding the 'S' dimension + 2" (51) (See note below).

NOTE: If the wall, floor or ceiling depth is less than the minimum depth, refer to Models 'GA' or 'OW' for the proper UL installation. Also, consider changing to a grille with a shallower overall depth.

TRANSFER OPENING

1. 'G' models for transfer opening 'S' set back is centered into the sleeve.
2. Minimum Sleeve lengths:
5" (127) for Models IBD2G, IBD2SSG, DIBD2G and DIBD2SSG
3 1/2" (89) for Model IBDTG
3. Minimum wall, floor, or ceiling depth equals the minimum sleeve length.
4. 3/4" (19) maximum grille depth.

NOTE: For floor, wall or ceiling depth less than 3 1/2" (89) to a minimum of 2" (51) in depth, stamped grilles will need to be utilized.

ORIENTATION

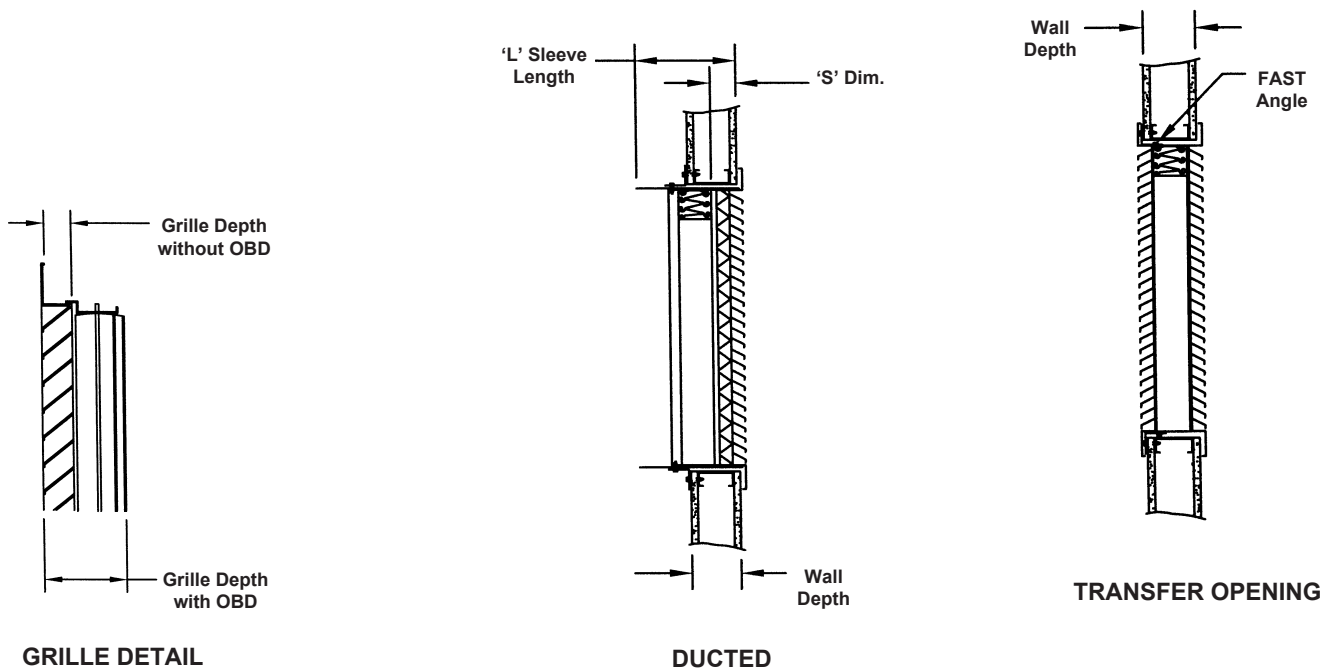
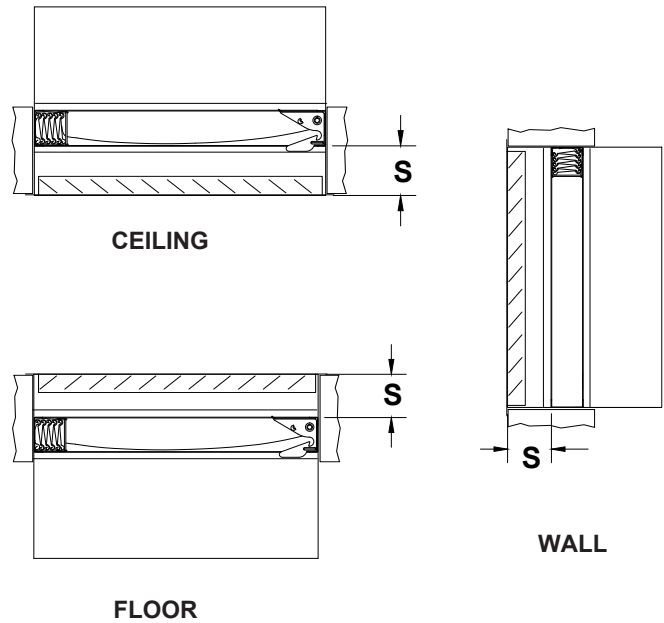

RUSKIN®

3900 Dr. Greaves Rd.
Kansas City, MO 64030
(816) 761-7476
FAX (816) 765-8955
www.ruskin.com