

## FLANGE FRAME OPTIONS FOR GALVANIZED STEEL HAT CHANNEL FRAMES

Front, rear and double flange frame options are available for galvanized steel hat channel frames. It is an option at additional cost. Specify front flange (FF), rear flange (RF), or double flange (DF) on the order. Flanges are available with Ruskin models:

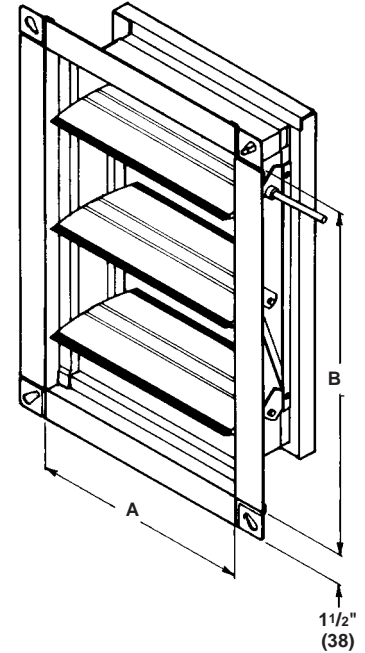

\*See appropriate damper specifications sheets.

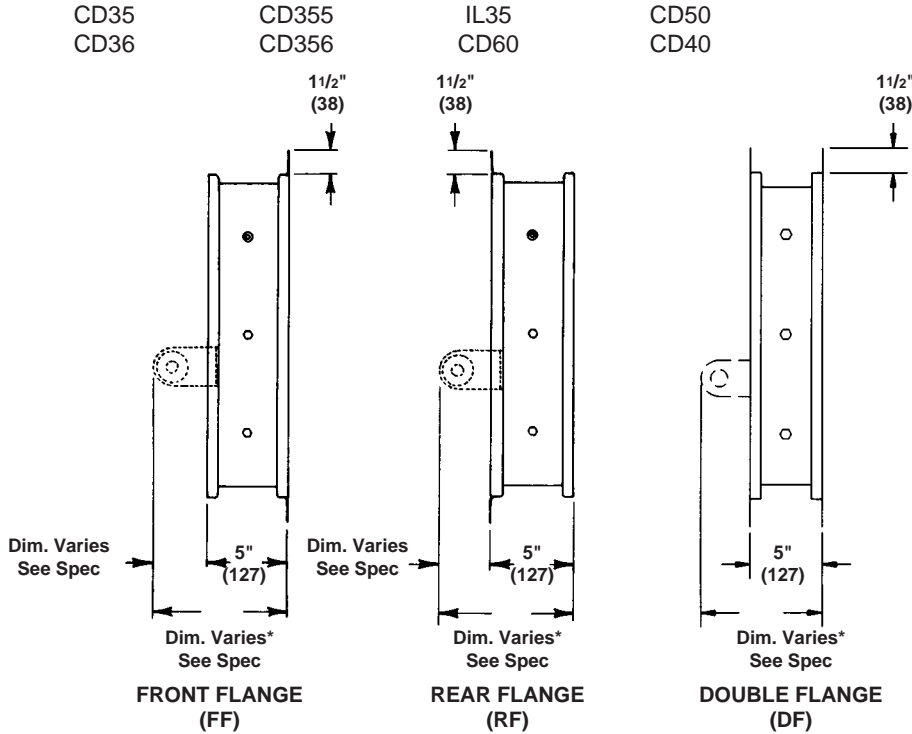
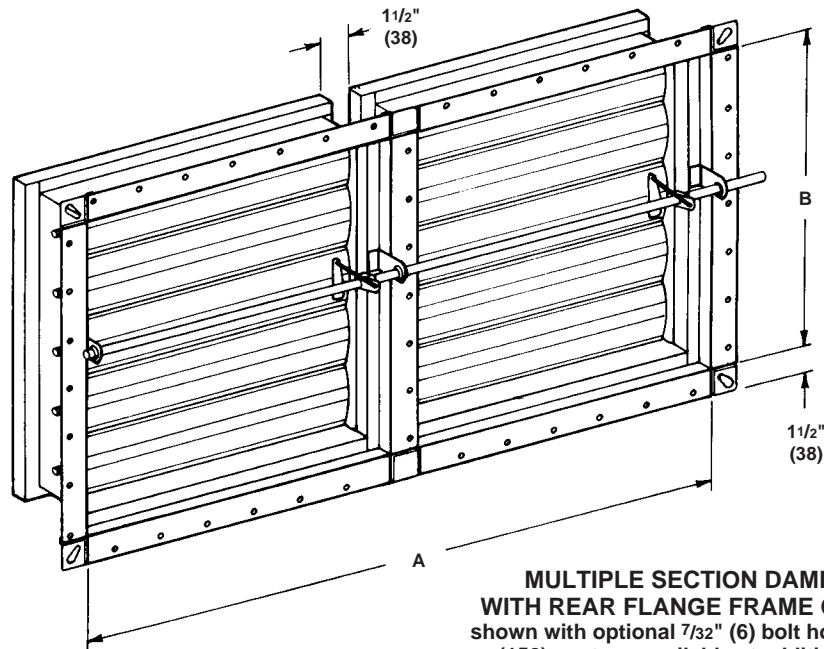

# MULTIPLE SECTION ASSEMBLY DETAILS

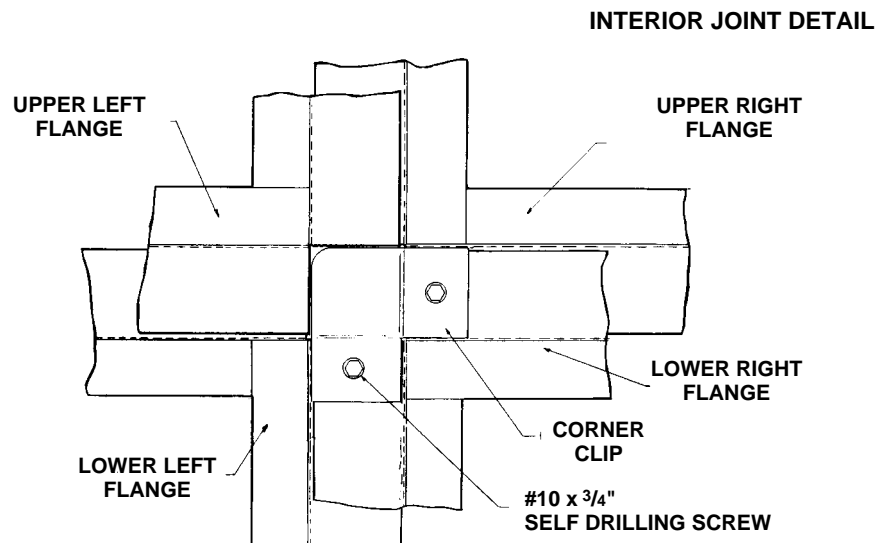
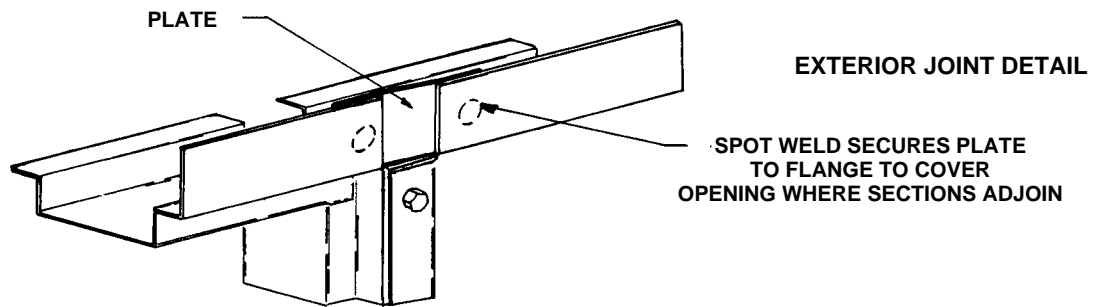
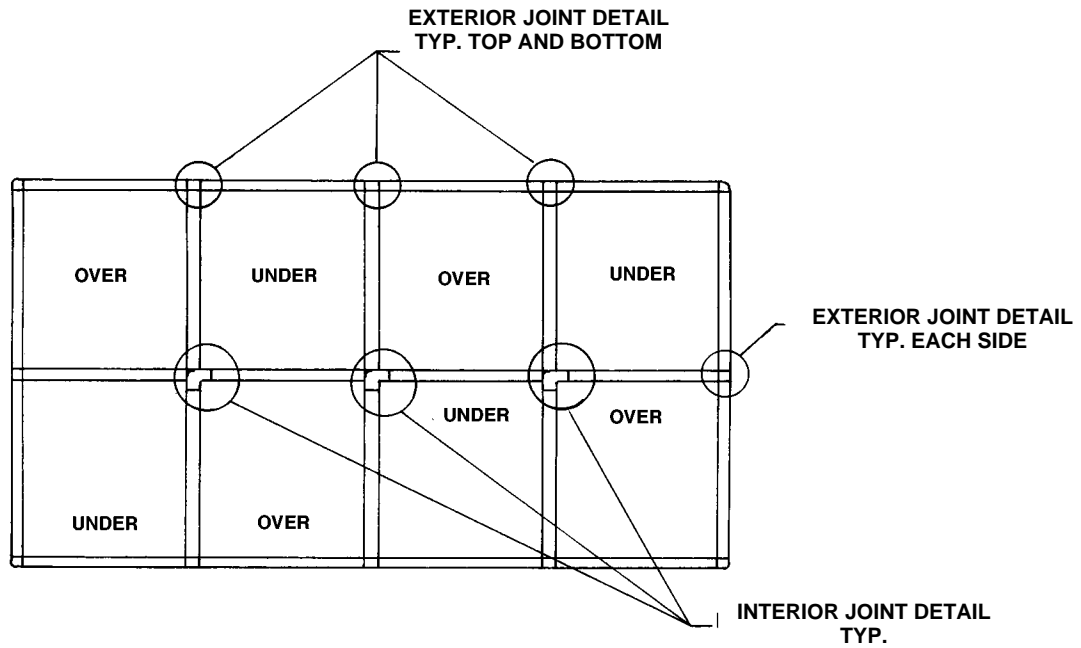

**RUSKIN**®

3900 Dr. Greaves Rd.  
Kansas City, MO 64030  
(816) 761-7476  
FAX (816) 765-8955  
www.ruskin.com