

RVD RADIAL VANE DIFFUSER

STANDARD CONSTRUCTION

FRAME

4" x 2" x 12 gage (102 x 51 x 2.8) steel angle (single flange).

BLADES

14 gage (2.0) steel.

AXLES

Full length 1/2" (13) diameter plated steel, welded at both ends.

HUB

1/8" (3) wall steel tubing.

MOUNTING STRAP

10 gage (3.5) steel. Four mounting straps supplied with units through 36" (914) diameters and six mounting straps supplied with units above 36" (914) diameter.

FINISH

White epoxy enamel.

MAXIMUM TEMPERATURE

200°F (93°C).

MINIMUM SIZE

12" (305) inside diameter.

MAXIMUM SIZE

60" (1524) inside diameter.

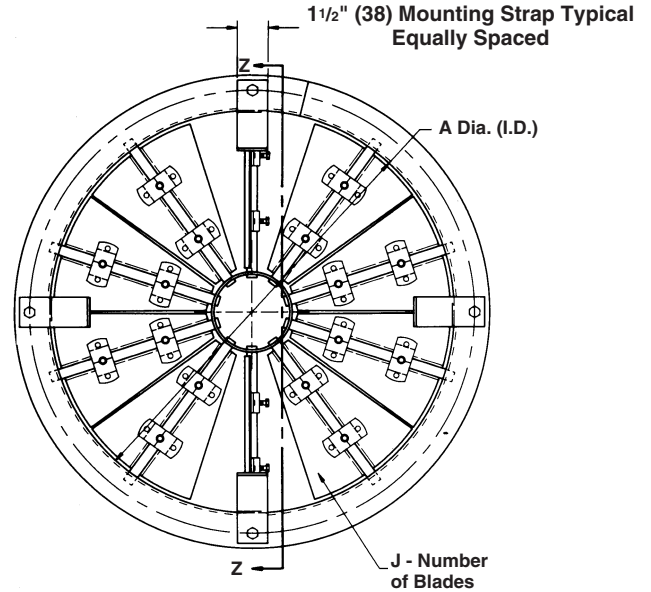

VARIATIONS

Variations to standard construction are available at additional cost and include:

- Higher temperature
- Special finishes
- Larger sizes.

STANDARD CONSTRUCTION			
A – DIAMETER		K	J
above	through		
12" (305) & above	16" (406)	4 ¹ / ₄ " (108)	6
16" (406)	20" (508)	4 ¹ / ₄ " (108)	8
20" (508)	33 ¹ / ₂ " (851)	4 ¹ / ₄ " (108)	10
33 ¹ / ₂ " (851)	37" (940)	4 ¹ / ₄ " (108)	11
37" (940)	41" (1041)	4 ¹ / ₄ " (108)	12
41" (1041)	45 ¹ / ₂ " (1156)	6" (152)	13
45 ¹ / ₂ " (1156)	52" (1321)	6" (152)	14
52" (1321)	60" (1524)	6" (152)	15

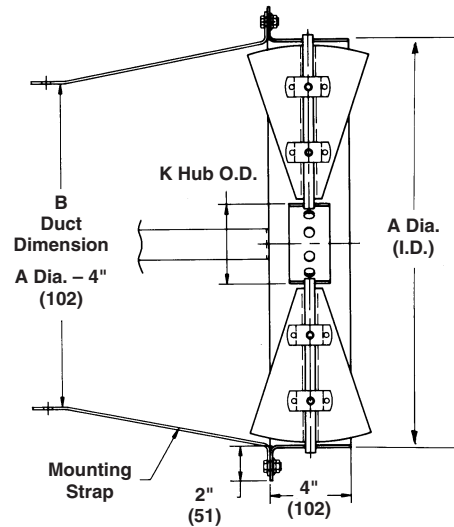

Dimensions shown in parenthesis () indicate millimeters.

QTY.	DIMENSIONS		VARIATIONS
	A - INSIDE DIA	B - DUCT DIM.	
JOB		LOCATION	
CONTRACTOR			

SUGGESTED SPECIFICATION

Furnish and install, at locations shown in plans or in accordance with schedules, radial vane diffuser dampers to meet the following construction standards: Frame shall be minimum 4" x 2" x 12 gage (102 x 51 x 2.8) steel angle with single flange. Blades shall be individually adjustable and settable constructed of a minimum 14 gage (2.0) steel. Radial Vane Diffuser dampers shall be rated for minimum 200°F (93°C) in its standard construction. Axles shall be mini-

mum 1/2" (13) diameter plated steel running full length of blade and welded at both ends. Standard construction shall include a minimum four mounting straps for units through 36" (914) diameter and six mounting straps for units above 36" (914) diameter. Mounting straps shall be constructed of minimum 10 gage (3.5) steel. Units shall be complete with white epoxy enamel finish. Radial Vane Diffuser damper shall be Ruskin Model RVD.

RUSKIN®

3900 Dr. Greaves Rd.
Kansas City, MO 64030
(816) 761-7476
FAX (816) 765-8955
www.ruskin.com