

## TS150 FIRESTAT FOR "REOPENABLE" FIRE AND SMOKE DAMPERS OPERATION INSTRUCTIONS SUPPLEMENT

### APPLICATION

The TS150 is a UL Classified heat responsive device which is used in conjunction with Ruskin fire/smoke dampers. The TS150 is an **optional** device which can be ordered with electric actuators or pneumatic actuators and EP (electro/pneumatic) switches. The TS150 allows the dampers to be reopened after the initial closure for dynamic smoke control. **The TS150 must be installed at the factory and cannot be added in the field. Replacement TS150's may be field installed with the approval of the local authority.**

### SMOKE DETECTION/TEST/POWER FAILURE OPERATION

If smoke is detected, or during testing, or if power failure occurs, the damper will close and lock. When the smoke signal ceases (or smoke detector resets), the test is complete or power is restored the SYSTEM will automatically REMOTE RESET the damper to the open position. The damper automatically resets if nuisance alarms occur and the SYSTEM is reset. The damper may be closed at any time by placing the MCP1 (optional) or other control switch (by others) in the CLOSED position.

### FIRE OPERATION

When the switch of a control panel (MCP) is in the NORMAL position and temperatures in excess of 165°F/74°C (212°F/100°C optional) are detected, the damper will close and lock and the damper CLOSED indicator light on the control panel will light.

The damper remains closed until the override signal for smoke management from a remote command station is present and the duct temperature has not exceeded the high limit. The high limit temperature sensor prevents the damper from reopening when duct temperature is above the damper's UL555S degradation test temperature of 250°F/121°C or 350°F/177°C. Upon cessation of the fire condition, the damper can be reopened by pressing the RESET button on the TS150 assembly. At no time will the damper disengage from the actuator. The integral SP100 will positively communicate to the fire commander via the control panel the position of the damper for smoke management purposes.

Refer to the appropriate damper installation instructions for details on damper installation. All electrical wiring and connections to the Fire-Stat must be in accordance with the standards of the authorities having jurisdiction.

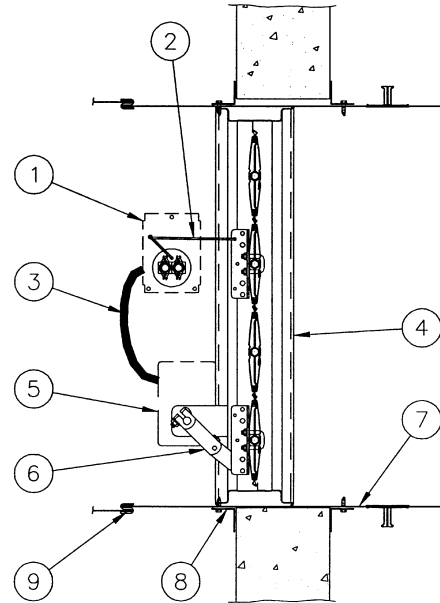

#### ITEM

1. TS-150 Fire Stat
2. Adjustable Connecting Rod
3. Flex Conduit
4. Damper Frame
5. Actuator or EP Switch

#### ITEM

6. Over-Center Lock
7. Damper Sleeve
8. FAST, PFMA or conventional mounting angles
9. Sleeve to Duct Connection (by others)

S1 and S2 Switch AMP Ratings: 15 AMPS, @ 24, 125 or 250 VAC 1/2 AMP, @ 125 VDC, 1/4 AMP, @ 250 VDC

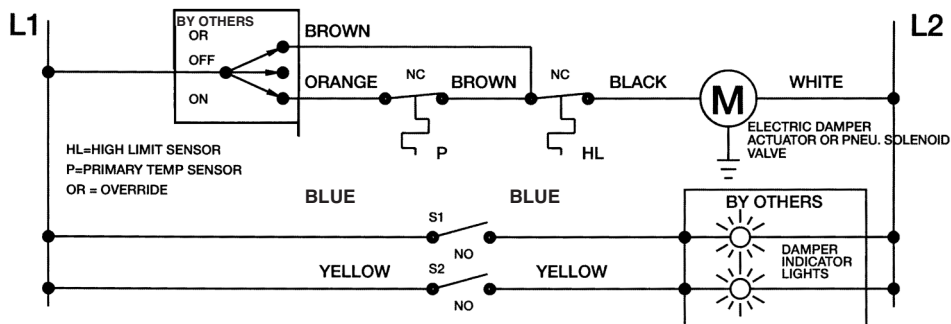
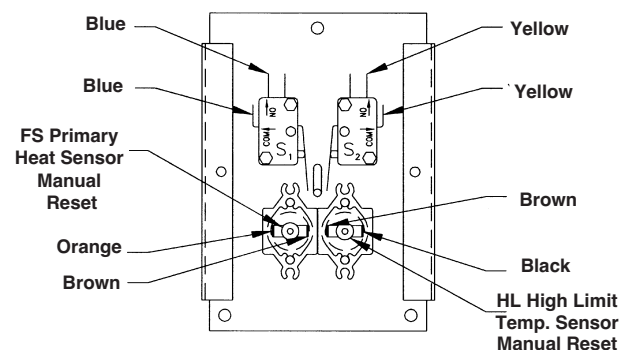

***RUSKIN***<sup>®</sup>

3900 Dr. Greaves Rd.  
Kansas City, MO 64030  
(816) 761-7476  
FAX (816) 765-8955  
[www.ruskin.com](http://www.ruskin.com)