

EVT-009 AND EVT-019 ENERGY RECOVERY VENTILATORS

APPLICATION

The EnERVent is an energy recovery ventilator with auxiliary heating and cooling capabilities. It is designed to provide outside air into a building without increasing the building HVAC load. The EnERVent is classified as a neutral air unit providing outside air into the building at room temperature.



STANDARD CONSTRUCTION

FRAME

Modular aluminum

CABINET

Galvanized steel, fully insulated double wall

BLOWERS

Silent Pro Series Class II FC

ACCESS DOORS

Hinged double wall with 1/4 turn latches

WHEEL

AHRI certified polymeric Enthalpy Wheel, complete with rotation sensor and stop, start, jog free cooling.

FILTERS

2" pleated MERV 8 (optional MERV11 and MERV13 available)

FINISH

Polyester resin based powder coat, off white color

CONTROL

Digital programmable logic controller. Single point wiring with NEMA 3R disconnect.

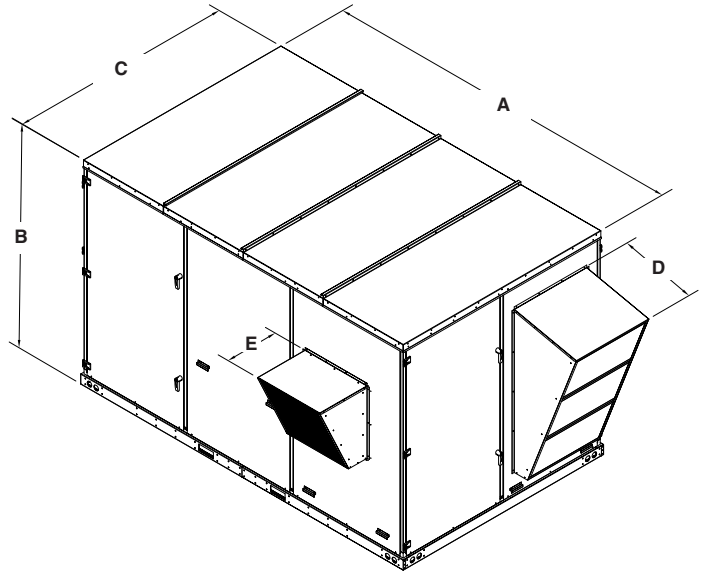

ENERVENT

OPTIONS

HEATING / COOLING

- R-410A DX COIL
- Chilled water coil
- Hot water coil
- Electric heat (pre & post)

FROST CONTROL

- Timed exhaust frost control
- Variable wheel speed frost control
- Electric Preheat

FILTERS

- 2" (51) Pleated MERV 11 or MERV 13 filters

DAMPERS

- Actuated exhaust air damper
- Actuated intake air damper

SENSORS

- Electronic Airflow Measuring
- Smoke Detectors
- CO₂ Sensors
- Dirty Filter Sensors

BLOWER MOTOR

- ODP or TEFC motors available

INTAKE LOUVER

- EME Wind Driven rain louver

ROOF CURBS

GFCI SERVICE OUTLET

CUSTOM PAINT

VFD BLOWER CONTROL

SENSIBLE WHEEL ONLY

Model EVT-09 or EVT-019	QTY.	MOTOR DATA			Roof Curb		OPTIONS Other (List)	TAG
		Voltage	Phase	Cycle	14"	24"		

SPECIFICATIONS AND ELECTRICAL DATA

		EVT-009			EVT-019		
Line Voltage - 60Hz		230v/3ph	460v/3ph	575v/3ph	230v/3ph	460v/3ph	575v/3ph
Supply Air Blower	Motor HP L/M/H	1 / 1 / 1.5	1 / 1 / 1.5	1 / 1 / 1.5	1 / 1.5 / 2	1 / 1.5 / 2	1 / 1.5 / 2
	Drive Type	Belt	Belt	Belt	Belt	Belt	Belt
	Size (DxW)	9 x 4	9 x 4	9 x 4	10 x 6	10 x 6	10 x 6
	Blower Speed	2894	2894	2894	2488	2488	2488
	Adjustment	Sheave	Sheave	Sheave	Sheave	Sheave	Sheave
	Bearing Type	Ball	Ball	Ball	Ball	Ball	Ball
	Full Load Amps	3 / 3 / 4.2	1.5 / 1.5 / 2.1	1.5 / 1.5 / 2.1	3 / 4.2 / 5.6	1.5 / 2.1 / 2.8	1.08 / 1.56 / 2.08
	Service Factor	1.15	1.15	1.15	1.15	1.15	1.15
Exhaust Air Blower	Motor HP L/M/H	1 / 1 / 1.5	1 / 1 / 1.5	1 / 1 / 1.5	1 / 1.5 / 2.0	1 / 1.5 / 2.0	1 / 1.5 / 2.0
	Drive Type	Belt	Belt	Belt	Belt	Belt	Belt
	Size (DxW)	9 x 4	9 x 4	9 x 4	10 x 6	10 x 6	10 x 6
	Blower Speed	2894	2894	2894	2488	2488	2488
	Adjustment	Sheave	Sheave	Sheave	Sheave	Sheave	Sheave
	Bearing Type	Ball	Ball	Ball	Ball	Ball	Ball
	Full Load Amps	3 / 3 / 4.2	1.5 / 1.5 / 2.1	1.08 / 1.08 / 1.56	3 / 4.2 / 5.6	1.5 / 2.1 / 2.8	1.08 / 1.56 / 2.08
	Service Factor	1.15	1.15	1.15	1.15	1.15	1.15
Wheel Data	Potential Volts	208/230v/1ph	208/230v/1ph	208/230v/1ph	208/230v/1ph	208/230v/1ph	208/230v/1ph
	Motor Speed	1050 RPM	1050 RPM	1050 RPM	1050 RPM	1050 RPM	1050 RPM
	Full Load Amps	0.3	0.3	0.3	0.6	0.6	0.6
	Wheel Model	ERC-2510C	ERC-2510C	ERC-2510C	ERC-3019C	ERC-3019C	ERC-3019C
	Depth	3	3	3	3	3	3
	Dia. (Nom. in.)	25	25	25	30	30	30
Preheat	No. of Stages	1	1	1	2	2	2
	kW/Stage	3	3	3	3	3	3
	MCA/Circuit	9	4.5	3.8	9	4.5	3.8
	MOCP	9	5	4	20	9	8
Post Heat	No. of Stages	1	1	1	2	2	2
	kW/Stage	9.6	9.6	9.6	9.6	9.6	9.6
	MCA/Circuit	28.88	14.44	12.05	28.88	14.44	12.05
	MOCP	30	15	15	60	30	25
	Total MCA	28.88	14.44	12.05	57.80	28.9	24.1
	Point Power	Separate	Separate	Separate	Separate	Separate	Separate
Total	MCA Minimum	6.3	3.3	2.46	6.6	3.6	2.76
	MOCP Minimum	7.5	5	3	7.5	5	3
	MCA Maximum	45.38	22.84	18.79	86.2	43.38	35.74
	MOCP Maximum	50	25	20	100	50	40

Effectiveness		Sensible	Latent	Total	Sensible	Latent	Total
AHRI Ratings	Total @ 100%	76%	68%	73%	68%	61%	65%
	Total @ 75%	81%	73%	78%	72%	67%	71%
	Net @ 100%	76%	68%	72%	68%	61%	64%
	Net @ 75%	81%	73%	76%	72%	67%	70%

AIRFLOW PERFORMANCE

EVT-009 SUPPLY & EXHAUST AIR PERFORMANCE RATINGS																	
AIR VOLUME (CFM)	OUTLET VELOCITY (FMP)	EXTERNAL STATIC PRESSURE (in. w.g.)															
		0.00		0.50		1.00		1.50		2.00		2.50		3.00		3.50	
		RPM	BHP	RPM	BHP	RPM	BHP	RPM	BHP	RPM	BHP	RPM	BHP	RPM	BHP	RPM	BHP
600	1250	1120	0.20	1338	0.28	1536	0.37	1721	0.47	1893	0.58						
700	1458	1249	0.29	1446	0.38	1624	0.48	1792	0.59	1952	0.70	2105	0.83	2251	0.95		
800	1667	1375	0.40	1557	0.51	1720	0.62	1874	0.74	2020	0.86	2162	0.99	2229	1.12	2432	1.26
900	1875	1495	0.53	1667	0.66	1819	0.78	1961	0.91	2097	1.04	2228	1.17	2356	1.31	2480	1.46
1000	2083	1618	0.69	1781	0.83	1924	0.97	2057	1.11	2185	1.25	2307	1.39	2426	1.54	2542	1.70

EVT-009 low and medium speeds use same hp motor and same size blowers.

EVT-019 SUPPLY & EXHAUST AIR PERFORMANCE RATINGS																	
AIR VOLUME (CFM)	OUTLET VELOCITY (FMP)	EXTERNAL STATIC PRESSURE (in. w.g.)															
		0.00		0.50		1.00		1.50		2.00		2.50		3.00		3.50	
		RPM	BHP	RPM	BHP	RPM	BHP	RPM	BHP	RPM	BHP	RPM	BHP	RPM	BHP	RPM	BHP
800	1385			1002	0.27	1216	0.38										
1150	1769			1088	0.42	1281	0.55	1453	0.70	1610	0.85						
1400	2154	987	0.46	1175	0.61	1349	0.77	1508	0.94	1656	1.12	1794	1.29	1923	1.47		
1650	2538	1096	0.69	1263	0.86	1421	1.05	1568	1.24	1706	1.43	1837	1.63	1960	1.84	2078	2.05
1900	2923	1205	0.97	1353	1.17	1497	1.38	1632	1.59	1761	1.81	1884	2.04	2002	2.26		

LOW SPEED

MED SPEED

HIGH SPEED

Empty space means this operating point is outside the efficient operating range of the blower.

NOTES

1. This blower data accounts for the pressure drop across the Energy Recovery Wheel and the internal cabinet losses, but does **not** include the pressure drop for selected Accessories and Options which can be found in the corresponding tables and must be added to the External Static Pressure to determine correct RPM and BHP.
2. BHP rating does not include drive losses.
3. Performance ratings do not include the effects of appurtenances in the air stream.
4. Drives are sized for a minimum of 150% of driven horsepower.

ENERVENT SUGGESTED SPECIFICATION

GENERAL

Ruskin Energy Recovery Ventilator shall be listed per UL 1995, Heating and Cooling Equipment. Energy transfer ratings of the energy recovery wheel shall be AHRI Certified. Performance shall be as scheduled on plans. Exhaust discharge and outside air intake shall not be located on the same side on roof top units. Basis of design is Ruskin Model EVT.

UNIT CASING AND FRAMES

EVT frame shall be constructed of aluminum. EVT panels shall be G90 galvanized steel. All panels exposed to the weather shall be a minimum of 18 gauge galvanized steel. EVT shall be internally lined with galvanized sheet metal creating a double wall. Where top panels are joined there shall be an overlapping, standing seam to insure positive weather protection. All metal-to-metal seams shall be factory sealed, requiring no caulking at job site. EVT base to be designed for curb mounting. EVT base shall overhang the curb for a positive seal against water run-off. Ruskin EVT exterior panels shall be powder coated for superior finish.

WEATHERHOODS

Weatherhoods shall be the same finish as the ERV. Outdoor air weatherhood shall incorporate a hooded design and moisture eliminator.

INSULATION

EVT casing to be insulated with 1 inch fiberglass. Insulation shall meet requirements of NFPA 90A and tested to meet UL 181 requirements. Insulation to be enclosed in double wall construction.

ENERGY RECOVERY WHEEL

Wheel shall be of the enthalpy type for both sensible and latent heat recovery and be designed to insure laminar flow. Energy transfer ratings must be AHRI Certified to Standard 1060 and bear the AHRI certification symbol for AHRI Air-to-Air Energy Recovery Ventilation Equipment Certification Program based on AHRI 1060. Ratings "in accordance with 1060" without certification are not acceptable. Desiccant shall be silica gel for maximum latent energy transfer. Wheel shall be constructed of lightweight polymer media to minimize shaft and bearing loads. Polymer media shall be mounted in a stainless steel rotor for corrosion resistance. Wheel design shall consist of removable segments for ease of service and/or cleaning. Silica gel desiccant shall be permanently bonded to wheel media to retain latent heat capability after cleaning. Wheels with sprayed on desiccant coatings are not acceptable. Wheels with desiccant applied after wheel formation are not acceptable. Energy recovery device shall transfer moisture entirely in the vapor phase. Energy recovery drive belt material shall be prestretched high strength urethane and shall be factory installed, eliminating the need for field belt tension adjustment. Link style belts are not acceptable.

FREE COOLING MODE

The on-board control logic shall automatically cease energy recovery when outside air conditions are within a 40°F to 70°F (4°C to 21°C) temperature range to allow for space cooling. During the free cooling period, the wheel shall automatically jog at preset time intervals to purge wheel of moisture and contaminant build up.

ACCESS DOORS

All components shall be easily accessible through hinged access doors for exhaust, supply, filter, and damper compartments. Energy recovery wheels shall be mounted in a slide-out track for inspection, removal, and cleaning.

ROOF CURBS

Roof curb to be supplied by EVT manufacturer for field assembly. Curb shall consist of die formed galvanized steel sections. Curb shall be full perimeter type with gasket provided for field installation between curb and EVT base.

FAN SECTIONS

Centrifugal fans to be double width, double inlet, forward curved type. All blower wheels shall be statically and dynamically balanced. Steel fan shafts shall be ground and polished and shall be mounted in permanently lubricated, sealed ball bearing pillow blocks. Bearings shall be selected for a minimum (L10) life in excess of 100,000 hours at maximum cataloged operating speeds. Adjustable sheaves on belt-driven fans with motors less than 15hp shall allow independent balancing of exhaust and supply airflows. Fan and motor assemblies are mounted to EVT base with neoprene isolators as standard. Fans shall be located in draw-through position in reference to the energy recovery wheel.

MOTORS AND DRIVES

Motors shall be energy efficient, complying with EPACT standards, for single speed ODP and TEFC enclosures. Motors shall be permanently lubricated, heavy-duty type, matched to the fan load and furnished at the specified voltage, phase, and enclosure. Drives shall be sized for a minimum of 150% of driven horsepower. Pulleys shall be of the fully machined cast type, keyed and securely attached to the fan wheel and motor shafts; 10 horsepower and less shall be supplied with an adjustable drive pulley. Energy wheel motors shall have integral overload protection.

FILTERS

Supply and exhaust filters shall be 2-inch thick pleated fiberglass with a minimum MERV 8 rating. MERV 11 or 13 filters are optional. Filter racks shall be die-formed galvanized steel.

ELECTRICAL

All internal electrical components shall be factory wired for single point power connection. Units with electric preheat or post heat will be wired with independent power supply. All electrical components shall be UL Listed, Approved, or Classified where applicable and wired in compliance with the National Electrical Code. Weatherproof, integral door interlocking disconnect switch, motor starters, control circuit fusing, control transformer for 24 VAC circuit, and terminal strip shall be supplied as standard components in the control center. Motor starters consist of a contactor and Class 20 electronic adjustable overload protection and shall be provided for all motors in the unit. Ruskin's ER optimizer PLC controller is included to control all unit functions and outputs and will be fully compliant with BAS systems including LONWORKS, BACNET, and MODBUS.

DX COOLING COILS

Direct expansion (DX) shall be factory tested and rated in accordance with AHRI 410. Coils shall have rifled copper tubes with permanently expanded aluminum fins and shall be equipped with adjustable expansion valve connected to distributors.

CHILLED AND HOT WATER COILS

Water coils shall be factory tested and rated in accordance with AHRI 410. Coils shall have copper tubes with permanently expanded aluminum fins.

ELECTRIC HEAT COILS

Electric heat shall be UL listed and circuit fused per NEC over 48 amps. Heater shall be sequentially controlled via on-board sequencers. Electric heat shall be factory wired and installed. Control will be 24 volt with class 2 transformer. Standard air flow proving switch will shut down heater if air ceases to flow across heating elements.

The electric preheat option provides frost protection for year round operation. It features steel finned tubular heater with high temperature baked-on aluminum finish protecting them from corrosion and deterioration. Modular heat stages for single or dual stage heat are provided.

The post electric heat option utilizes nickel chromium electric wire resistance elements and allows for modular heat stages for single or multiple stage heat.



3900 Dr. Greaves Rd.
Kansas City, MO 64030
(816) 761-7476
FAX (816) 765-8955
www.ruskin.com

Printed on recycled paper
using vegetable based inks

