

GENERIC VISIBLE MULLION STYLE

Installation Guide



PRE-ASSEMBLY INSTRUCTIONS:

1. Remove louvers & accessories from shipping containers & inspect for damage. Single section units will be shipped fully assembled. Multi-section units will be shipped in shipping sections to be assembled at the job site. Large multi section units may be packaged in more than one shipping crate.
2. Care must be taken when handling components. Lift louver sections carefully by the supports or frames. Avoid lifting by louver blades. Do not apply excessive force to any point of the section. Lift at multiple points, if necessary to avoid deformation or racking of components.
3. Inspect louvers & components after removal from containers. Verify that all components & fasteners are accounted for. Report any shortages immediately to Ruskin manufacturing.
4. Inspect the openings that the louvers will be installed in. Verify that the openings are square & that the unit will fit prior to installation. Check available installation depth for possible HVBS interference. If HVBS must be notched or modified for installation, secure the HVBS to a suitable substrate as close to the modification as possible to maintain structural integrity.
5. Contact your local Ruskin representative if you have questions pertaining to this installation or other field modifications.
6. Ensure that you have received ship loose parts & a box with hardwares.

ASSEMBLY PROCEDURE:

1. Install extended sill in the opening (if applicable).
2. Locate ship loose hardware required for louver multi-section assembly.
3. Position the louver sections faced down on a level, non-abrasive surface in the configuration they will be assembled in. Reference the tag numbers on each section to ensure the sections are in correct order.
4. Refer to appropriate exploded details for splice hardware identification & location. Now fasten the sections together at frames, support splices. (Supports are pre-drilled at plant for ease).
5. If perimeter clips or continuous angles are to be installed, locate & anchor them in the opening. (Reference clip angle installation guide for instructions).
6. Level the louver assembly both horizontally & vertically in the opening using shims. (Shims not provided by Ruskin).
7. Position the louver in the opening so that the desired sealant joint will be maintained around the perimeter of louver.
8. After louver is secured, install backer rod & sealant around louver perimeter. (Sealant not provided by Ruskin).

REFERENCE IMAGES

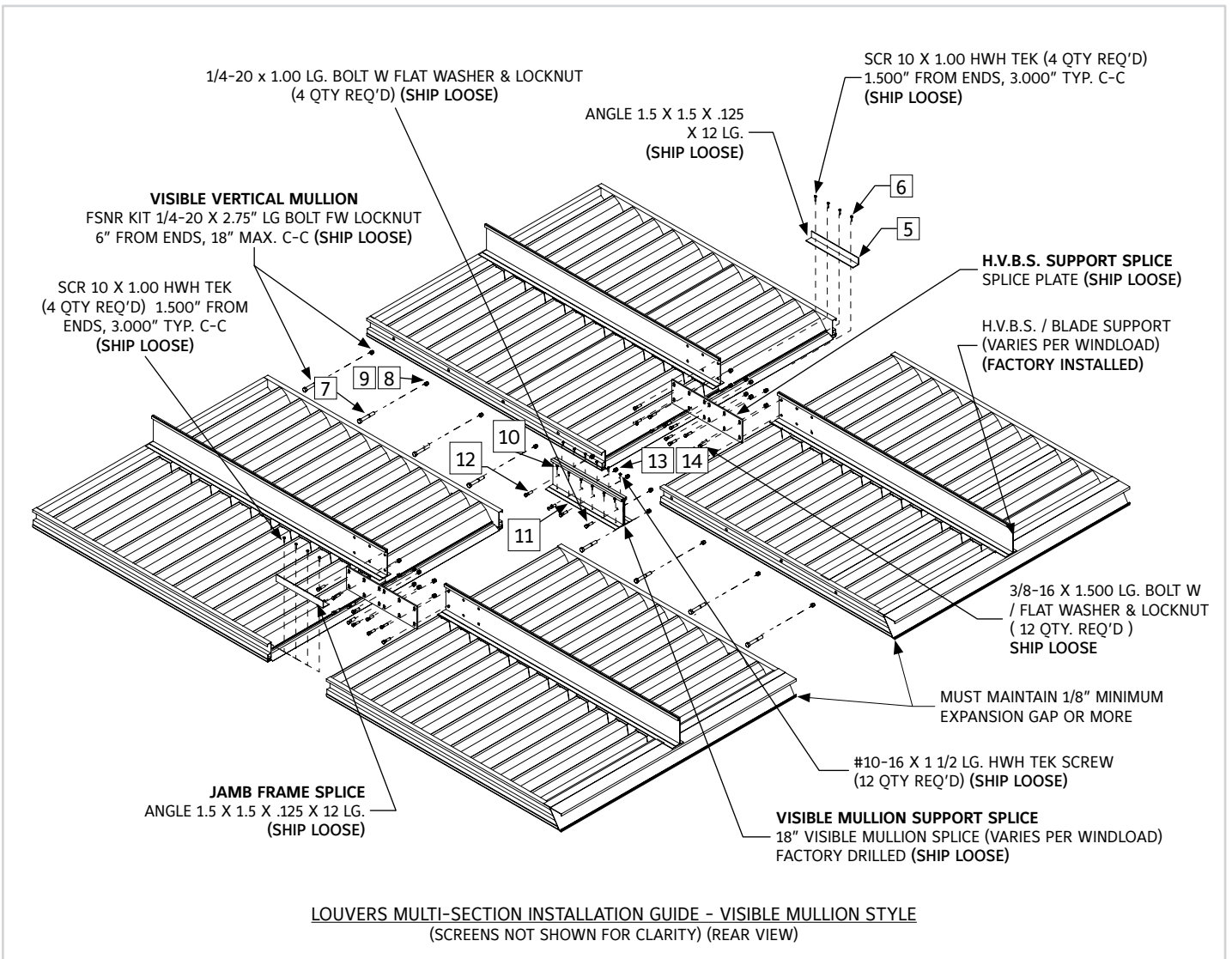

ITEM #	DESCRIPTION	QTY.	PART #	MATERIAL
PARTS LIST TABLE - H.V.B.S SPLICE (SHIP LOOSE)				
1	SPL PLT HDG 5 X 18 X 1/4	1	360500786	HOT DIPPED GALVANIZED
2	BLT 3/8-16 X 1.50 HHD	12	38006800	ZC
3	NUT NYLOCK 3/8-16	12	380430951	ZC
4	WSH FLAT 3/8-16 USS	12	38026500	ZC
PARTS LIST TABLE - JAMB FRAME SPLICE (SHIP LOOSE)				
5	ANGLE 1.5 X 1.5 X .125 X 12 LG.	1	360437300	EXT ALUM. 6063-T5 .125" THK
6	SCR 10 X 1.00 HWH TEK	4	380430941	410 SS/ZC
PARTS LIST TABLE - VISIBLE VERTICAL MULLION (SHIP LOOSE)				
7	BLT 1/4-20 X 2.75 HHD	1	380431729	ZC
8	NUT NYLOCK 1/4-20	1	38009500	ZC
9	WSH FLAT 1/4 USS	1	38026300	ZC

** Square balloons refer ship loose parts

ITEM #	DESCRIPTION	QTY.	PART #	MATERIAL
PARTS LIST TABLE - MULLION SPLICE (SHIP LOOSE)				
10	SCR 10 X 1.500 HWH TEK	12	380430830	410/ZC
11	FRM SPLICE EX LVR VIS MUL (18.000" LG.)	2	360437301	6063-T6 EXTRUDED ALUM.
12	BOLT 1/4-20 X 1.00 HHD	4	38007500	ZC
13	NUT NYLOCK 1/4-20	4	38009500	ZC
14	WSH FLAT 1/4-20 USS	4	38026300	ZC

1X2 MULTI-SECTION INSTALLATION

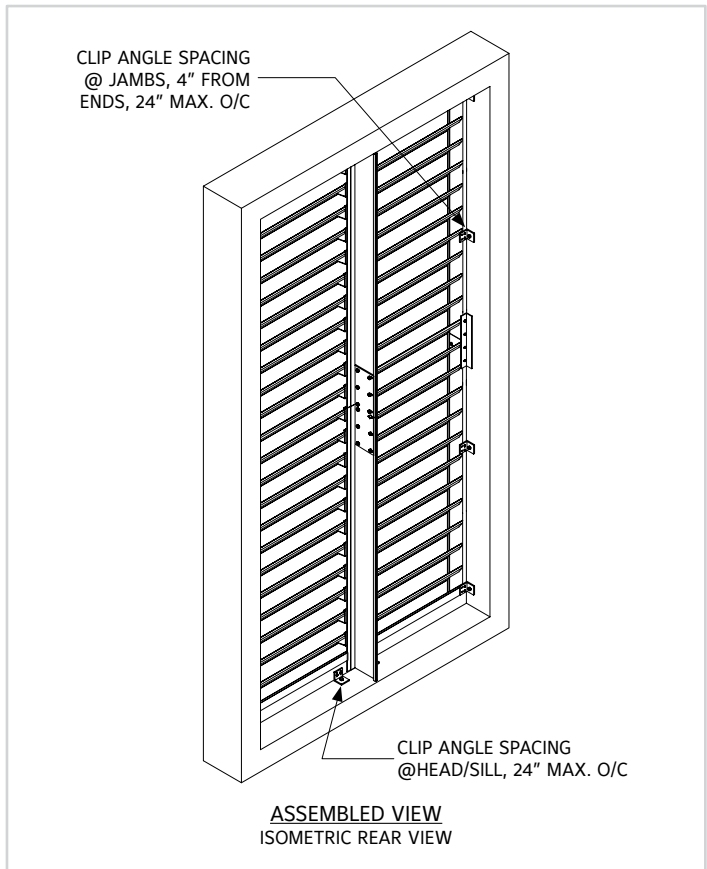
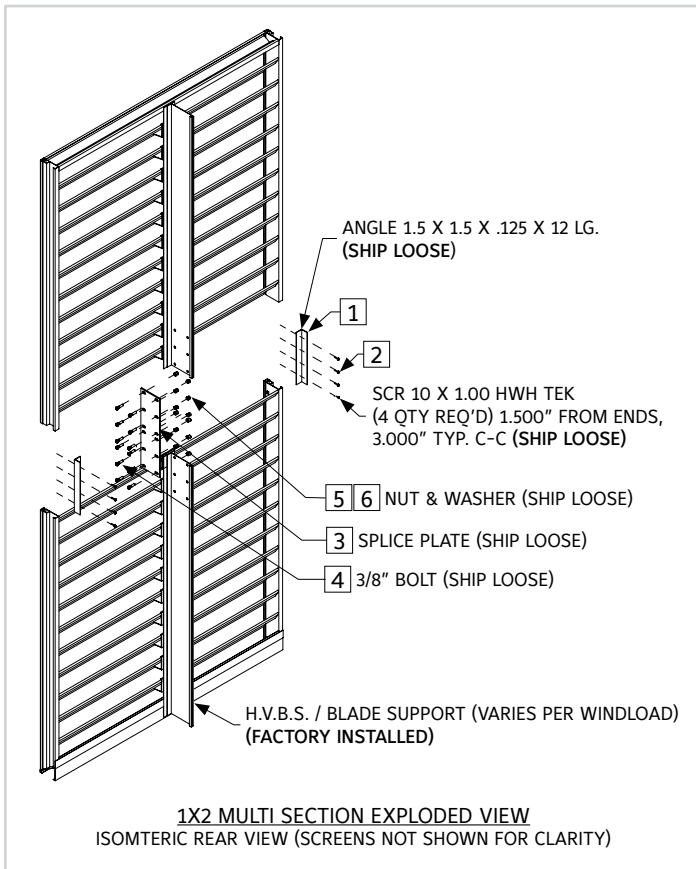

ITEM #	DESCRIPTION	QTY.	PART #	MATERIAL
PARTS LIST TABLE - 1X2 MULTI SECTION (SHIP LOOSE)				
1	ANGLE 1.5 X 1.5 X .125 X 12 LG.	1	360437300	EXT ALUM 6063-T5 .125" THK
2	SCR 10 X 1.00 HWH TEK	4	380430941	410/ZC
3	SPL PLT HDG 5 X 18 X 1/4	1	360500786	HOT DIPPED GALVANIZED
4	BLT 3/8-16 X 1.50 HHD	12	36006800	ZC
5	NUT NYLOCK 3/8-16	12	380430951	ZC
6	WSH FLAT 3/8-16 USS	12	38026500	ZC

2X1 MULTI-SECTION INSTALLATION

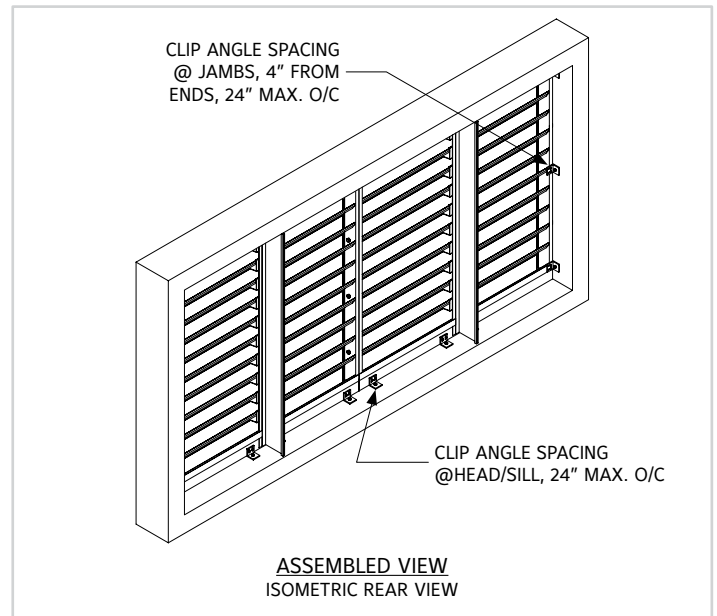
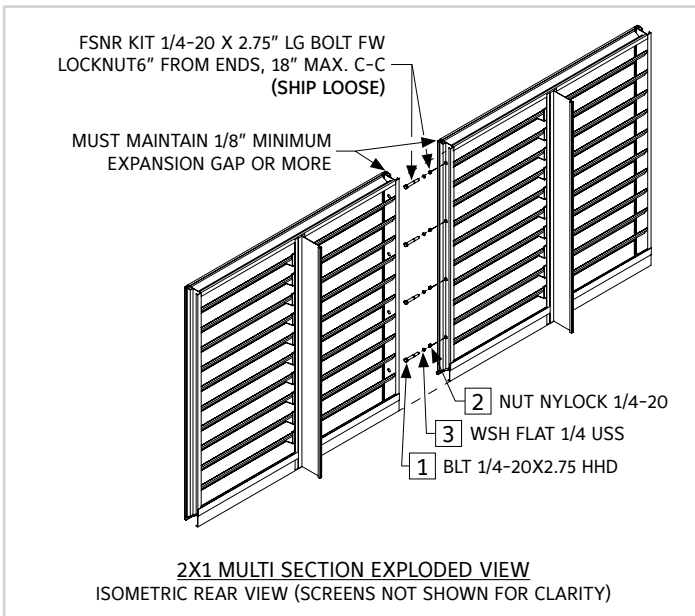

ITEM #	DESCRIPTION	QTY.	PART #	MATERIAL
PARTS LIST TABLE - 2X1 MULTI SECTION (SHIP LOOSE)				
1	BLT 1/4-20 X 2.75 HHD	1	380431729	ZC
2	NUT NYLOCK 1/4-20	1	38009500	ZC
3	WSH FLAT 1/4 USS	1	38026300	ZC

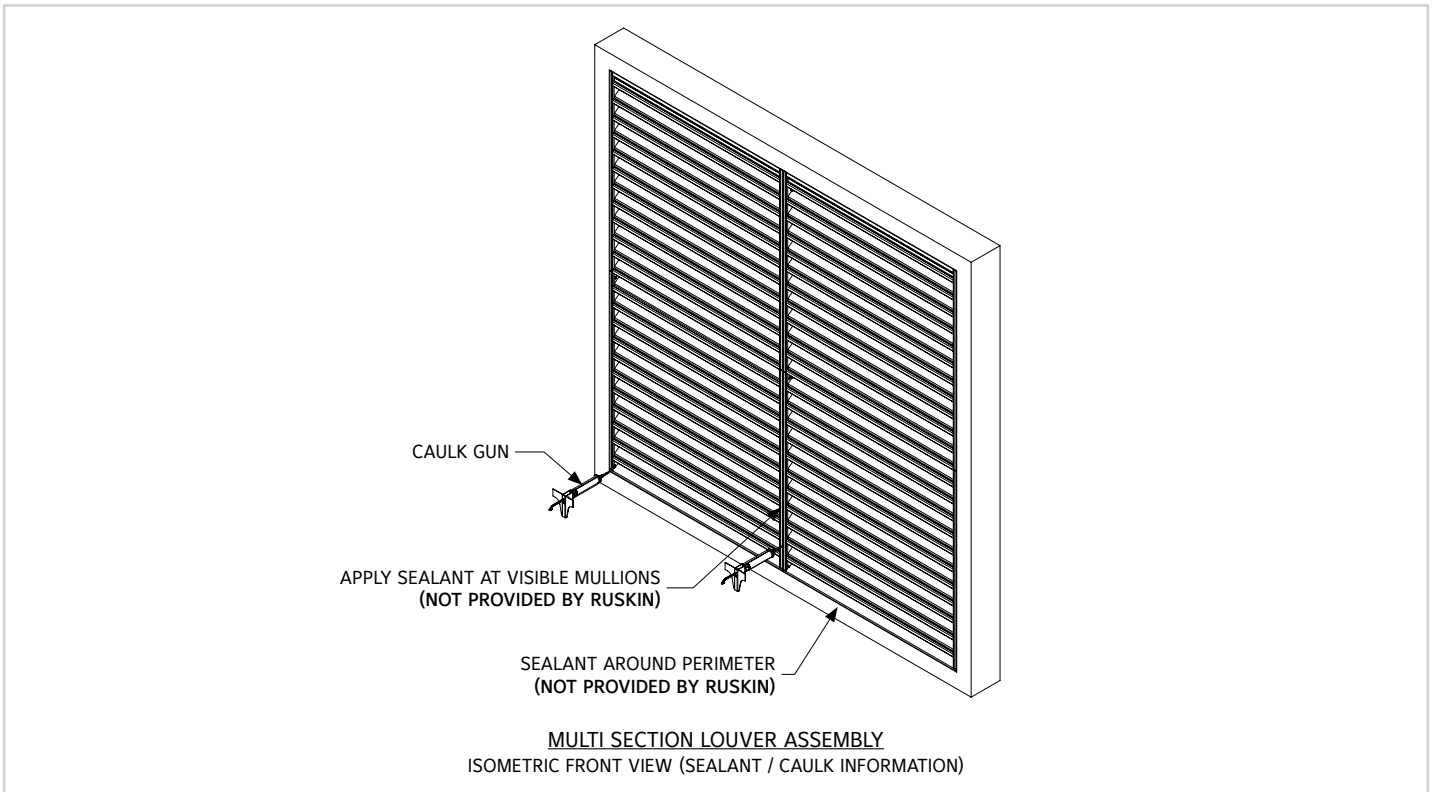

LINKS TO IMPORTANT DOCUMENTS

Document Title

Limited Warranty Document



3900 Doctor Greaves Road
Grandview, MO 64030
Website: www.ruskin.com
Phone: (816) 761-7476