

S05, S10, S20 Series Spring Return Direct Coupled Actuators

MS4105, MS4110, MS4120, MS71XX, MS7505, MS7510, MS7520,
MS8105, MS8110, MS8120

PRODUCT DATA



FEATURES

- Brushless DC submotor with electronic stall protection for floating/modulating models.
- Brush DC submotor with electronic stall protection for 2-position models.
- Self-centering shaft adapter (shaft coupling) for wide range of shaft sizes.
- Models available with three torque ratings: 44 lb-in. (5 N•m), 88 lb-in. (10 N•m), and 175 lb-in. (20 N•m).
- Models available for use with two-position, single pole single throw (spst), line- (Series 40) or low- (Series 80) voltage controls.
- Models available for use with floating or switched single-pole, double-throw (spdt) (Series 60) controls.
- Models available for use with proportional current or voltage (Series 70) controls.
- Models available with combined floating/modulating control in a single device.
- Models available with adjustable zero and span.
- Models available with line-voltage internal end switches.
- Access cover to facilitate connectivity.
- Metal housing with built-in mechanical end limits.
- Spring return direction field-selectable.
- Shaft position indicator and scale.
- Manual winding capability with locking function.
- UL (cUL) listed and CE compliant.
- All Models are plenum-rated per UL873.

APPLICATION

MS41XX, MS71XX, MS75XX, MS81XX Spring Return Direct Coupled Actuators (DCA) are used within heating, ventilating, and air-conditioning (HVAC) systems. They can drive a variety of quarter-turn, final control elements requiring spring return fail-safe operation.

Applications include:

- Volume control dampers, mounted directly to the drive shaft or remotely (with the use of accessory hardware).
- Quarter-turn rotary valves, such as ball or butterfly valves mounted directly to the drive shaft.
- Linear stroke globe or cage valves mounted with linkages to provide linear actuation.

Contents

Application	1
Features	1
Specifications	2
Ordering Information	2
Installation	4
Wiring	8
Operation	12
Checkout	13



SPECIFICATIONS

Models: See Tables 2 and 3.

NOTE: This document also covers the MS7110K and MS7106K.

Dimensions: See Fig. 1.

Device Weight: 7 lb (3.2 kg).

Temperature Ratings:

Ambient: -40°F to 140°F (-40°C to 60°C).
Shipping and Storage: -40°F to 158°F (-40°C to 70°C).

Humidity Ratings: 5% to 95% RH noncondensing.

Electrical Connections:

Field wiring 14 to 22 AWG (2.0 to 0.344 mm sq) to screw terminals, located under the removable access cover.

Electrical Ratings: See Table 1.

End Switches (Two SPDT):

Settings (fixed): 7° nominal stroke, 85° nominal stroke.
Ratings (maximum load):
Low-Voltage Models: 250 Vac, 5A resistive, 3A inductive.
Line-Voltage Models: 250 Vac, 5A resistive.

Mounting: Self-centering shaft adapter (shaft coupling).
Round Damper Shafts: 0.375 to 1.06 in. (10 to 27 mm).
Square Damper Shafts: 1/2 to 3/4 in. (13 to 19 mm).
Actuator can be mounted with shaft in any position.

NOTE: For 175 lb-in. (20 N•m) models: 3/4 in. or greater shaft diameter recommended.

Minimum Damper Shaft Length: 1 in. (25 mm); 3 in. (76 mm) recommended.

Timing (At Rated Torque and Voltage):

Drive Open (typical):
Floating, Modulating Models: 90 seconds.
Floating, Modulating Models: 60 seconds.
Two-Position Models: 45 seconds ±5 seconds.
Spring Close: 20 seconds typical.

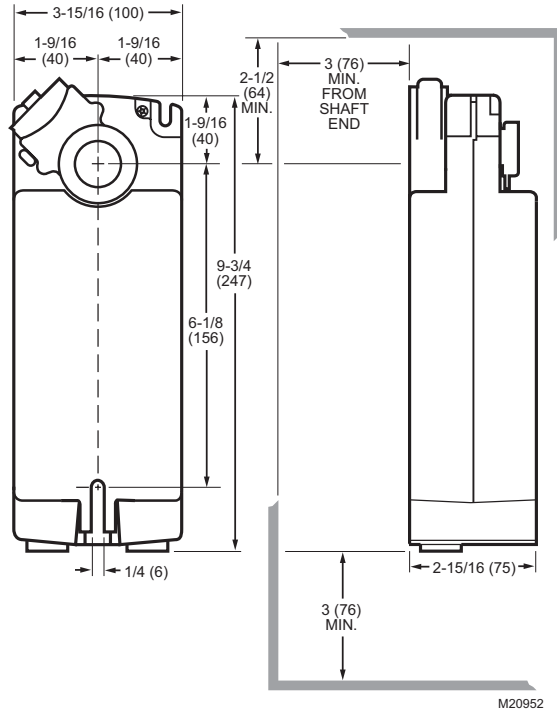

Fig. 1. Dimensional drawing of actuator in in. (mm).

Table 1. Electrical Ratings*.

Model(s)	Power Input		Power Consumption (VA)					
	Voltage	Frequency	44 lb-in. (5 N•m)		88 lb-in. (10 N•m)		175 lb-in. (20 N•m)	
			Driving	Holding	Driving	Holding	Driving	Holding
Floating, Modulating	24 Vac ±20% (Class 2), 24 Vdc	50/60 Hz.	13	5	14	5	16	5
Two-Position, Low-voltage	24 Vac ±20% (Class 2), 24 Vdc	50/60 Hz.	25	8	30	8	40	8
Two-Position, Line-voltage	100-250 Vac	50/60 Hz.	45	13	45	13	60	13

* Floating/Modulating 60 sec models
88 lb-in. (10 N•m) 14 VA Driving
175 lb-in. (20 N•m) 18 VA Driving

ORDERING INFORMATION

When purchasing replacement and modernization products from your TRADELINE® wholesaler or distributor, refer to the TRADELINE® Catalog or price sheets for complete ordering number.

If you have additional questions, need further information, or would like to comment on our products or services, please write or phone:

1. Your local Honeywell Automation and Control Products Sales Office (check white pages of your phone directory).
2. Honeywell Customer Care
1885 Douglas Drive North
Minneapolis, Minnesota 55422-4386

In Canada—Honeywell Limited/Honeywell Limitée, 35 Dynamic Drive, Toronto, Ontario M1V 4Z9.

International Sales and Service Offices in all principal cities of the world. Manufacturing in Australia, Canada, Finland, France, Germany, Japan, Mexico, Netherlands, Spain, Taiwan, United Kingdom, U.S.A.

Table 2. O.S. Number Selection (see Table 3 also).

M	Electrical Motor
S	Fail Safe Function (Spring Return)
41	120 Vac Two-Position Control; Reversible Mount
71	24 Vac Modulating Control; Reversible Mount
75	24 Vac Modulating and Floating Control; Reversible Mount
81	24 Vac Two-Position Control; Reversible Mount
05	44 lb-in. (5 N•m)
10	88 lb-in. (10 N•m)
20	175 lb-in. (20 N•m)
A^a	Standard U.S. Model
B^b	Standard European Model
E^b	Selectable control signal; Adjustable zero and span; Includes service and auto-adapt modes
H^a	
1	No Feedback
2	Voltage Feedback Signal
0	No End Switches
2	Two End Switches
XX	System Controlled Numbers

M	S	75	20	A	2	0	XX
----------	----------	-----------	-----------	----------	----------	----------	-----------

^a Model manufactured for sale in the United States.

^b Model manufactured for sale in Europe.

60 second models

- MS7510A2016
- MS7510A2214
- MS7520A2015
- MS7520A2213

Table 3. Actuator Catalog Numbering (see Table 2 also).

S	Spring Return Fail Safe Mode
N	Non-Spring Return Fail Safe Mode
05	44 lb-in. (5 N•m); Spring Return Only
10	88 lb-in. (10 N•m); Spring Return Only
20	175 lb-in. (20 N•m)
34	300 lb-in. (34 N•m); Non-Spring Return Only
24	24 Vac Floating (Series 60) Control
24-2POS	24 Vac Two-Position Control
120-2POS	120 Vac Two-Position Control
230-2POS	230 Vac Two-Position Control
010	24 Vac Modulating and Floating Control
	Fixed Zero/Span, No End Switches
-SW2	Internal End Switches
-SER^a	Enhanced Modulating; Adjustable Zero/Span

S	10	24-2POS	-SW2
----------	-----------	----------------	-------------

^a Enhanced models include two internal end switches.

Stroke: 95° ±3°, mechanically limited.

Approvals: See Table 4.

Design Life (at Rated Voltage):**

Two-position models: 50,000 full stroke cycles;
50,000 full stroke spring returns.
Floating and Modulating models: 60,000 full stroke cycles;
1,500,000 repositions; 60,000 full stroke spring returns.

Controller Type:

S05, S10, S20: See Table 3.
S05, S10, S20: Modulating (Series 70) or Floating (Series 60);
controlled by selector switch.
MS71XX: Modulating Voltage Input.
Input Impedance: 95K ohms minimum.
Feedback Signal: 0 or 2-10 Vdc;
Driving current is 3 mA minimum.

Torque Ratings:

Typical Holding, Driving, Spring Return:
S05: 44 lb-in. (5 N•m).
S10: 88 lb-in. (10 N•m).
S20: 175 lb-in. (20 N•m).
Stall Maximum (fully open at 75°F):
S05: 100 lb-in. (11.3 N•m).
S10: 200 lb-in. (22.6 N•m).
S20: 350 lb-in. (39.6 N•m).

Noise Rating at 1m (Maximum):

Holding: 20 dBA (no audible noise).
Two-position models:
Driving: 50 dBA.
Spring Return: 65 dBA.
Floating and Modulating models:
Driving: 40 dBA.
Spring Return: 50 dBA.

Table 4. Approvals.

	S05, S10, S20 Series	MS7110, MS7106
UL/cUL	X	X
UL873 Plenum Rating, File No. E4436; Guide No. XAPX.	X	X
CE	X	
C-TICK	X	

Environmental Protection Ratings:

NEMA2 (US Models) or IP54 (European Models) when mounted on a horizontal shaft with access cover below the shaft.

Accessories:

- 27518 Balljoint (5/16 in.).
 - 103598 Balljoint (1/4 in.).
 - 205860 Electronic Minimum Position Potentiometer.
 - 27520A-E,G,H-L,Q Pushrod (5/16 in. diameter).
 - 32000085-001 Water-tight Cable Gland/Strain-relief Fitting (10 pack).
 - 32003036-001 Weather Enclosure.
 - 32004254-002 Self-Centering Shaft Adapter (supplied with actuator).
 - 50001194-001 Foot Mount Kit.
 - 50005859-001 NEMA4/4X Enclosure.
 - 50006427-001 Anti-Rotation Bracket (supplied with actuator).
 - SW2-US Auxiliary Switch Package.
- See also Form 62-2620.

** Floating/Modulating 60 sec models

- 20,000 full stroke cycles
- 100,000 repositions

Sizing

Required Torque

In lieu of data from a Specification Engineer or Manufacturer, required torque for a given damper load can be determined using the following method: $T_R = T_D \times A_D$

Where:

- T_R = Required torque for the damper load.
- T_D = Damper torque rating from the manufacturer, expressed in either (lb-in.)/(sq ft) or (N•m)/(sq m), the damper load.
- A_D = Damper area expressed in either sq ft or sq m.

Actuators Required

In lieu of data from a Specification Engineer or Manufacturer, the number of required actuators for a given damper load can be determined using the following method:

$$N = \frac{T_R}{T_A \times SF}$$

Where:

- N = Number of actuators.
- T_R = Required torque for the damper load. (See above.)
- T_A = Actuator torque rating.
- SF = Safety factor.

NOTE: The safety factor accounts for variables such as mis-alignments, aging of the damper, etc. 0.8 is a typical safety factor.

INSTALLATION

When Installing this Product...

1. Read these instructions carefully. Failure to follow them could damage the product or cause a hazardous condition.
2. Check the ratings given in the instructions and on the product to make sure the product is suitable for your application.
3. Installer must be a trained, experienced service technician.
4. After installation is complete, check out product operation as provided in these instructions.

CAUTION

Electrical Shock or Equipment Damage Hazard.
Low voltage can shock individuals or short equipment circuitry.
 Disconnect power supply before installation.

IMPORTANT

All wiring must agree with applicable codes, ordinances and regulations.

Location

These actuators are designed to mount directly to a damper external drive shaft. The shaft coupling fastens to the drive shaft. The actuator housing includes slots which, along with an anti-rotation bracket, secure the actuator to the damper frame or duct work (see Fig. 8).

NOTES:

- When mounted correctly, these slots allow the actuator to *float* without rotating relative to the damper shaft.
- Using other brackets or linkages, the actuator can be foot-mounted or tandem-mounted.



CAUTION

Motor Damage Hazard.
Deteriorating vapors and acid fumes can damage metal parts.
 Install motor in areas free of acid fumes and other deteriorating vapors.



CAUTION



Equipment Damage Hazard.
Tightly securing actuator to damper housing can damage actuator.
 Mount actuator to allow it to float along its vertical axis.

Preparation

Before mounting the actuator onto the damper shaft, determine the:

- Damper/valve opening direction for correct spring return rotation. The actuator can be mounted to provide clockwise or counterclockwise spring return.
- Damper shaft size (see the Specifications section).

Determine Appropriate Mounting Orientation

The actuators are designed to open a damper by driving the damper shaft in either a clockwise  or counterclockwise  direction (see Fig. 2).

NOTES:

- Actuators are shipped in the fully closed (spring return) position.
- An arrow molded into the hub points to tick marks on the label to indicate the hub rotary position.

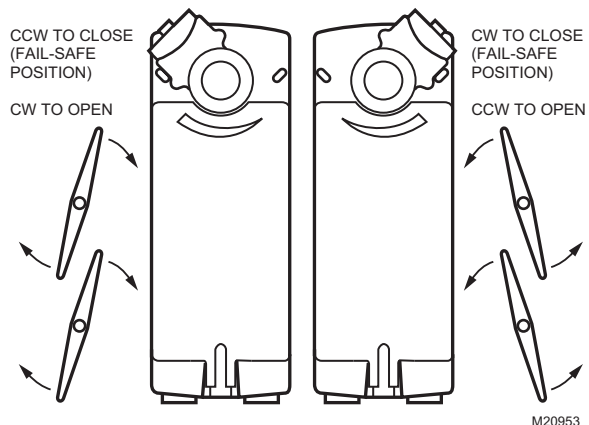

Fig. 2. Spring Return DCA mounting orientation.

Measure Damper/Valve Shaft Length

If the shaft is less than three inches in length, the shaft coupling must be located between the damper/valve and actuator housing. If the shaft length is more than three inches, the shaft coupling may be located on either side of the actuator housing.

If the coupling must be moved from one side of the actuator to the reverse, follow these instructions (see Fig. 3):

1. Remove the retainer clip from the shaft coupling and set it aside for later use.
2. Remove shaft coupling from one side of the actuator.
3. Replace the shaft coupling on the opposite side of the actuator aligning it based on the stroke labelling.
4. Replace the retainer clip on the shaft coupling using the groove of the coupling.

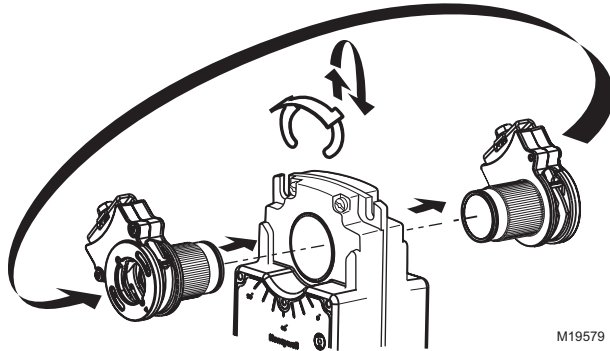

M19579

Fig. 3. Mounting shaft coupling to actuator opposite side.

Select Actuator Control Signal

These actuators are available in two control types:

- Standard: includes mode selection dial to select the desired input signal.

- Enhanced: includes different mode selection dial to select the desired input signal. Also includes dials for adjusting the input signal zero and span.

NOTE: Selections are made using a dial that appears on both the front and back of the actuator (see Fig. 4). For available options, see Table 5.

To select the control signal simply turn the mode selection dial to the desired control signal (as indicated on the device label).

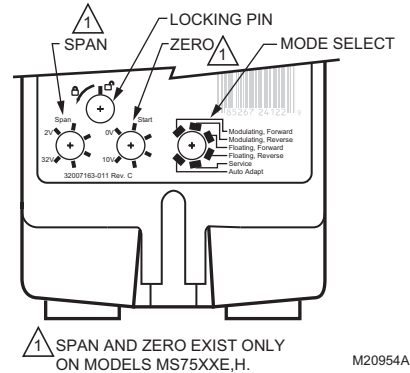

SPAN AND ZERO EXIST ONLY ON MODELS MS75XXE,H.

M20954A

Fig. 4. Dials for control signal and zero/span.

Table 5. Actuator Control Signal Selections.

Mode Options	Standard	Enhanced	Details
Floating: forward	X ^a	X ^a	Series 60 control. Power to terminal 4 drives toward spring return position.
Floating: reverse	X ^b	X ^b	Series 60 control. Power to terminal 3 drives toward spring return position.
Modulating: 0-10 Vdc	X ^c		Series 70 control. 0 Vdc signal drives toward spring return position.
Modulating: 10-0 Vdc	X ^c		Series 70 control. 10 Vdc signal drives toward spring return position.
Modulating: 2-10 Vdc	X ^c		Series 70 control. 2 Vdc signal drives toward spring return position.
Modulating: 10-2 Vdc	X ^c		Series 70 control. 10 Vdc signal drives toward spring return position.
Modulating: forward		X	Voltage input with adjustable zero and span. Minimum signal drives toward spring return position.
Modulating: reverse		X	Voltage input with adjustable zero and span. Maximum signal drives toward spring return position.
Service		X	Actuator hub stops in place and ignores control signal changes.
Auto-adapt		X	For setup only. Rescales to allow full input signal over mechanically limited stroke.

^a Feedback: MS75XXA,H and U.S. S... models are 2-10 Vdc, MS75XXB,E and European S... models are 0-10 Vdc.

^b Feedback: MS75XXA,H and U.S. S... models are 10-2 Vdc, MS75XXB,E and European S... models are 10-0 Vdc.

^c When operating in Modulating mode, the feedback signal matches the control signal.

Non-Standard Stroke

Mechanical Stroke Limit Reduction

For applications requiring a span less than 95 degrees, a simple adjustment can be made. When the rotational mounting of the shaft coupling is changed, the actuator drives less than the full 95 degrees stroke.

The stroke is adjustable in 5 degree increments. Once adjusted, the actuator drives until the shaft coupling reaches the mechanical stop (part of the housing). The stop causes the

motor to discontinue driving and the shaft coupling drives no farther. When the actuator returns, it stops at the fail-safe position.

To set the fail-safe position, proceed as follows:

1. Remove the retainer clip from the shaft coupling and set it aside for later use.
2. Remove shaft coupling from the actuator.
3. Rotate the coupling to the desired fail-safe position, aligning it based on the stroke labelling. See Fig. 5.

NOTE: The shaft coupling location determines the travel span.

EXAMPLE: Setting shaft coupling to an approximate fail-safe position of 35 degrees (as indicated on the housing) limits stroke to 60 degrees. (See Fig. 5)

4. Install the shaft coupling at this position.
5. Replace the retainer clip on the shaft coupling using the groove of the coupling.
6. If necessary, replace the holder and position indicator on the shaft coupling.

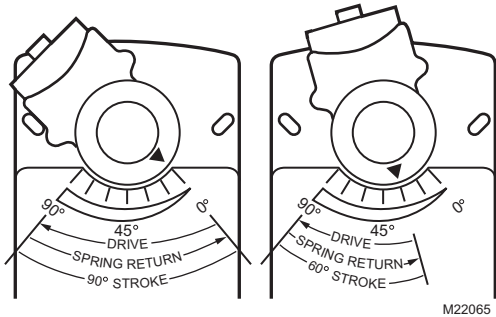

Fig. 5. Stroke reduction.

Adjustable Zero and Span (Enhanced Modulating Models only)

These actuators have the capability of adjustable zero and span. Fig. 4 shows the dials. These dials are present only on the Enhanced Modulating models. A basic description of these dials follows:

- Zero: Sets input voltage to define the 0% angle of rotation. It is factory set to 0 Vdc, and can be adjusted up to 10 Vdc.
- Span: Adjusts motor response to travel full stroke through the selected input span. It is factory set to 10 Vdc, and is adjustable from 2 to 32 Vdc.

SET ADJUSTABLE ZERO AND SPAN

1. Apply 24 Vac to the actuator.
2. Turn the zero dial (see Fig. 4) past the desired start point.
3. Using either a controller or signal generator, apply an input signal equal to the start point signal.
4. Slowly adjust zero toward the minimum setting until the actuator hub begins to move.
5. Turn the span dial (see Fig. 4) to the minimum setting (2 Vdc).
6. Using either a controller or signal generator, apply an input signal equal to the desired end point signal.
7. Allow the actuator to open fully.
8. Slowly adjust span toward the maximum setting until the actuator hub moves slightly from fully open.
9. Carefully adjust span knob toward minimum until the actuator hub returns to fully open.

Auto-Adapt

When using these actuators for standard stroke applications, this function can be ignored. When it is desirable to use a mechanically limited stroke (see Mechanical Stroke Limit Adjustment section), it is possible to use the Auto-Adapt feature to rescale the input signal over the new limited stroke.

1. Rotate actuator control signal dial to Auto-Adapt.

NOTE: The actuator will drive open, then closed to establish the new open and closed positions.

2. Return the actuator control signal dial to the desired input signal position.

Manual Positioning

The actuator can be operated with no power present. Use this feature during installation or to move and lock the damper or valve shaft position when there is no power.

To operate the manual positioning:

1. If the power is on, turn it off.
2. Insert supplied hex wrench (key) as shown in Fig. 6.
3. Rotate key in the direction indicated on the cover.
4. Once the desired position is reached, hold the key to prevent the spring return from moving the actuator.
5. With the key held in place, use a screwdriver to turn the gear train lock pin in the indicated direction until the detent is reached.

NOTE: At the detent, the pin resists further rotation.

6. Remove the key without rotating it further.

To release the manual positioning with no power present:

1. Insert supplied key.
2. Turn key 1/4 turn in the direction indicated on the cover.
3. Remove key without engaging the gear train lock pin.
4. The spring will return actuator to the fail-safe position.

NOTE: Once power is restored, the actuator will return to normal automated control.

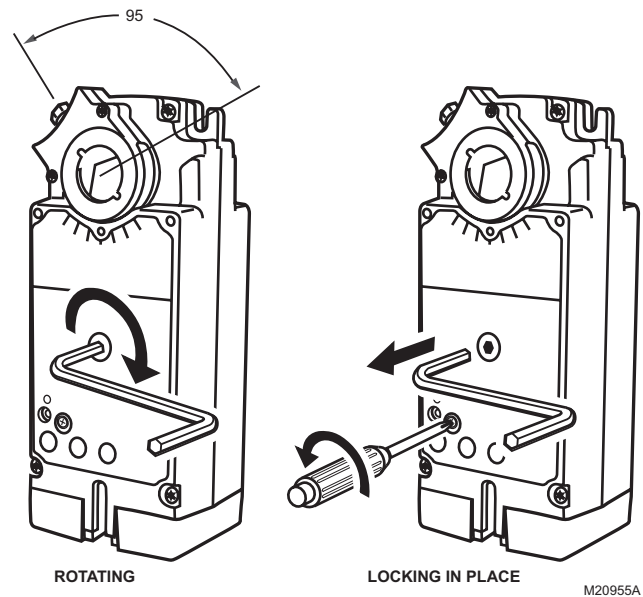

Fig. 6. Manual positioning.

Mounting



CAUTION

Device Malfunction Hazard.
Improper shaft coupling tightening causes device malfunction.

Tighten shaft coupling with proper torque to prevent damper shaft slippage.



CAUTION

Actuator Damage Hazard.
Using actuator as shaft bearing causes device damage.

Use actuator only to supply rotational torque. Avoid any side loads to actuator output coupling bearings.



CAUTION

Equipment Damage Hazard.
Can damage the motor beyond repair.

Never turn the motor shaft by hand or with a wrench. Forcibly turning the motor shaft can damage the gear train.

To mount the actuator to an external drive shaft of a damper, proceed as follows:

1. Place actuator over damper shaft; and hold mounting bracket in place. See Fig. 8.
2. Mark screw holes on damper housing.
3. Remove actuator and mounting bracket.
4. Drill or center-punch holes for mounting screws (or use no.10 self-tapping sheet metal screws).
5. Turn damper blades to desired normal (closed) position.
6. Place actuator and mounting bracket back into position and secure bracket to damper box with sheet metal screws.
7. Using 10 mm wrench, tighten shaft coupling securely onto damper shaft using minimum 120 lb-in. (13.6 N•m), maximum 180 lb-in. (20.3 N•m) torque.

NOTE: See Fig. 7 for proper mounting to a square damper shaft.

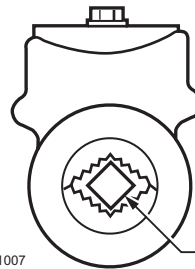
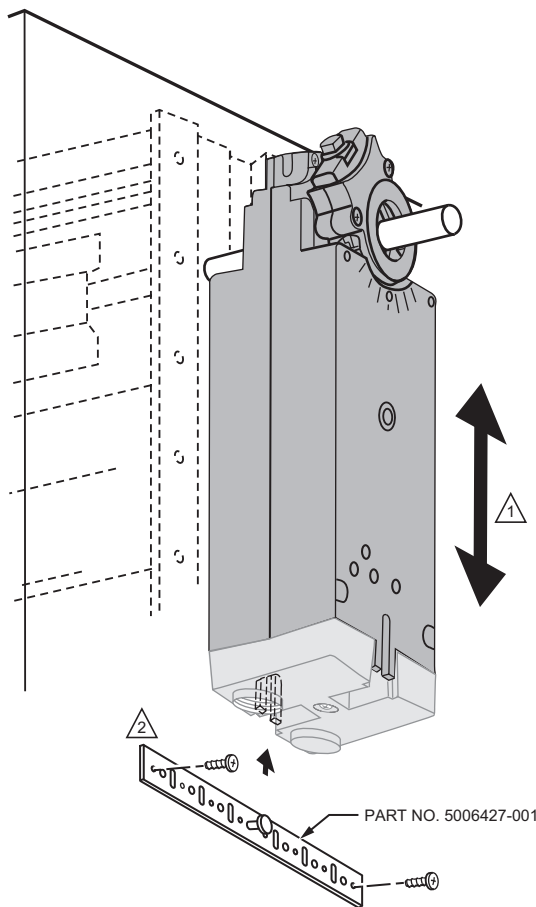

Fig. 7. Proper mounting to square damper shaft.



1 ENSURE THAT MOUNTING ASSEMBLY PREVENTS ACTUATOR ROTATION AND ALLOWS ACTUATOR TO FLOAT ALONG INDICATED AXIS. WHEN TOO TIGHT, THE RESULTING BINDING CAN DAMAGE THE ACTUATOR OR REDUCE TORQUE OUTPUT.

2 THE BRACKET CAN BE BENT TO ALLOW MOUNTING THE ACTUATOR PARALLEL TO THE MOUNTING SURFACE.

M20956

Fig. 8. Mounting actuator to damper housing.

WIRING

CAUTION

Electrical Shock or Equipment Damage Hazard.
Disconnect all power supplies before installation.
 Motors with auxiliary switches can have more than one disconnect.

IMPORTANT

All wiring must comply with local electrical codes, ordinances and regulations.

Access Cover Removal (Fig. 9)

CAUTION

Equipment Damage Hazard.
Improper cover removal can damage electric connections.
 Pull the cover along the axis of the actuator.
 The cover contains contact sockets that must connect to actuator contact pins.
 Bending these pins can permanently damage the device.

NOTE: This cover can be removed before or after actuator mounting.

In order to wire the device, the access cover must be removed as follows:

1. Remove the screw from the center of the cover, set the screw aside.
2. Pull the cover along the long axis of the actuator.
3. If the actuator is not yet mounted, set it aside.
4. Remove conduit dust covers as necessary.
5. Thread wire through conduit holes.
6. Connect wires as appropriate to the terminal block(s). (See Fig. 10 and 11.)

NOTE: With US Models, use 1/2 in. NPS strain relief gland or 1/2 in. conduit adapters. Recommend using flex conduit.
 With European Models, use M16 strain relief gland.

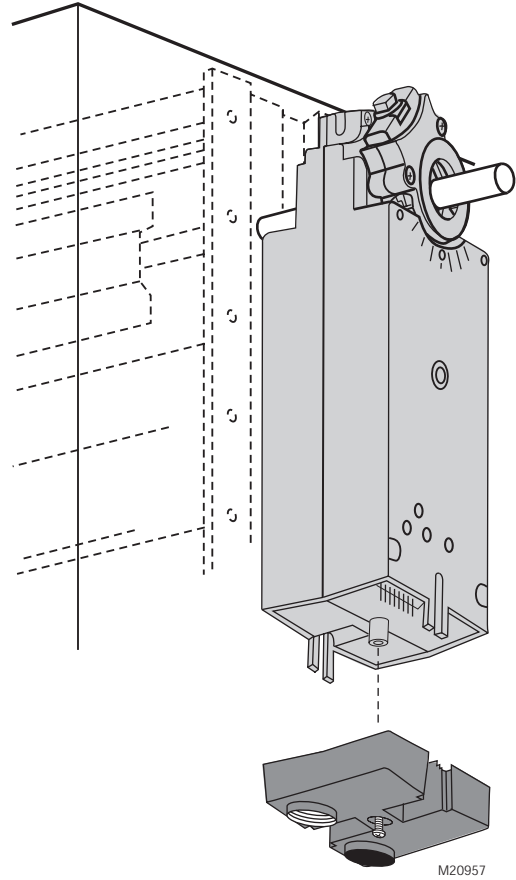

Fig. 9. Removing access cover.

Typical Wiring

See Fig. 10 through 26 for typical wiring details.

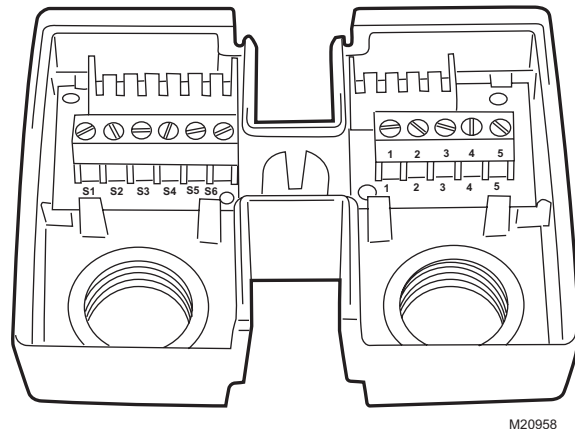
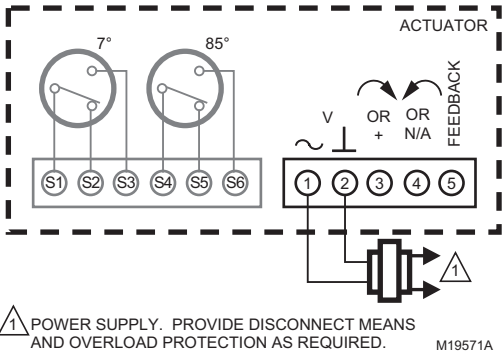

Fig. 10. Terminal block details.



▲1 POWER SUPPLY. PROVIDE DISCONNECT MEANS AND OVERLOAD PROTECTION AS REQUIRED. M19571A

Fig. 11. Terminal block details.

Table 6. Wiring details.

Terminal	Floating	Modulating	Two-Position		Color ^a
			24 Vac	120 Vac 240 Vac	
1	~	power	power	power	Red
2	⊥	common	common	neutral	Black
3	↻	cw	—	—	White
4	↻ →	ccw	—	—	—
5	←	feedback	—	—	Brown

^a Only applies to models with wires.

Sxx24-2POS Models

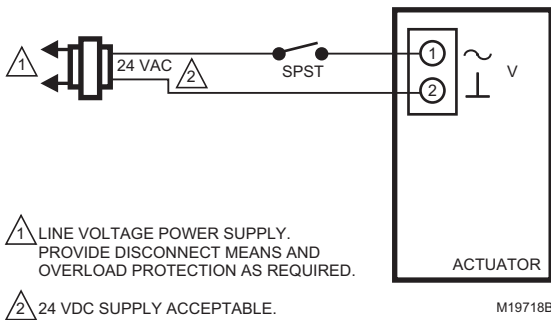

▲1 LINE VOLTAGE POWER SUPPLY. PROVIDE DISCONNECT MEANS AND OVERLOAD PROTECTION AS REQUIRED.

▲2 24 VDC SUPPLY ACCEPTABLE. M19718B

Fig. 12. Wiring for low-voltage two-position control.

Sxx120-2POS, Sxx230-2POS Models

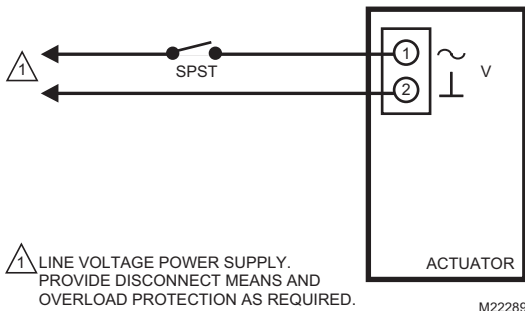

▲1 LINE VOLTAGE POWER SUPPLY. PROVIDE DISCONNECT MEANS AND OVERLOAD PROTECTION AS REQUIRED. M22289

Fig. 13. Wiring for line-voltage two-position control.

Sxx010 Models

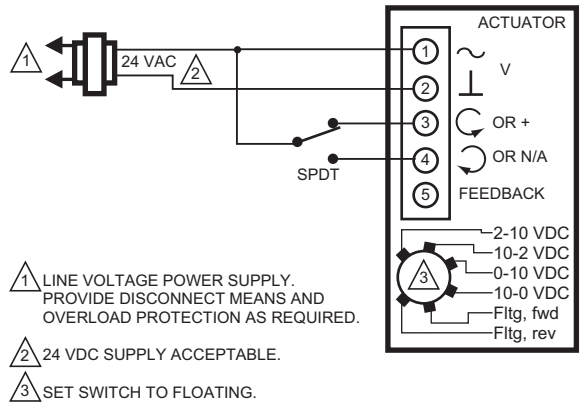

▲1 LINE VOLTAGE POWER SUPPLY. PROVIDE DISCONNECT MEANS AND OVERLOAD PROTECTION AS REQUIRED.

▲2 24 VDC SUPPLY ACCEPTABLE.

▲3 SET SWITCH TO FLOATING. M19572A

Fig. 14. Wiring for SPDT on/off control.

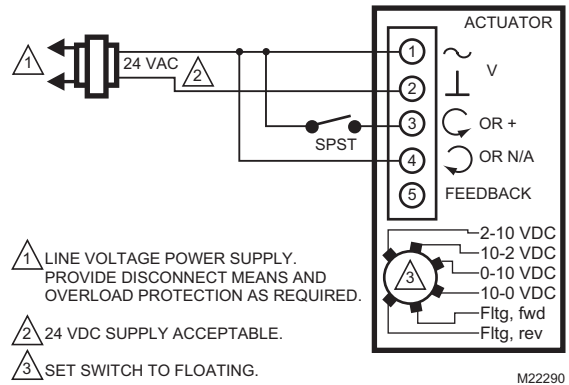

▲1 LINE VOLTAGE POWER SUPPLY. PROVIDE DISCONNECT MEANS AND OVERLOAD PROTECTION AS REQUIRED.

▲2 24 VDC SUPPLY ACCEPTABLE.

▲3 SET SWITCH TO FLOATING. M22290

Fig. 15. Wiring for SPST on/off control.

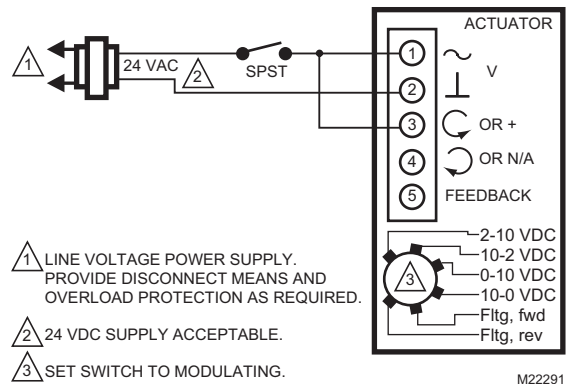

▲1 LINE VOLTAGE POWER SUPPLY. PROVIDE DISCONNECT MEANS AND OVERLOAD PROTECTION AS REQUIRED.

▲2 24 VDC SUPPLY ACCEPTABLE.

▲3 SET SWITCH TO MODULATING. M22291

Fig. 16. Wiring for two-wire SPST on/off control.

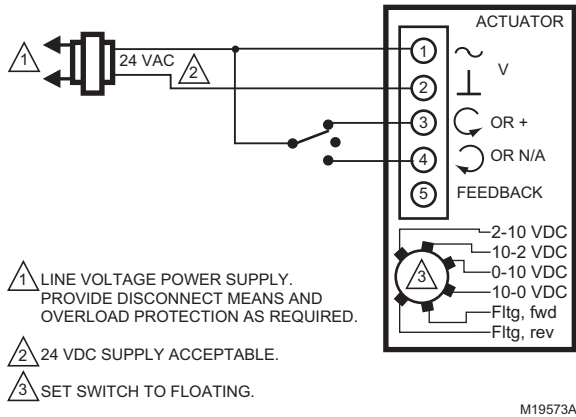

Fig. 17. Wiring for floating control.

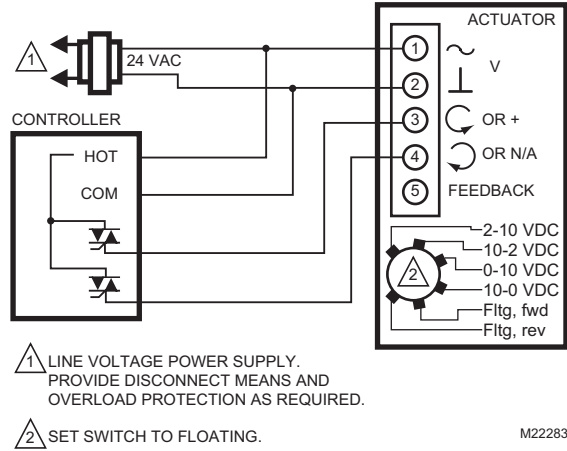

Fig. 20. Wiring for high side (triac source) floating control.

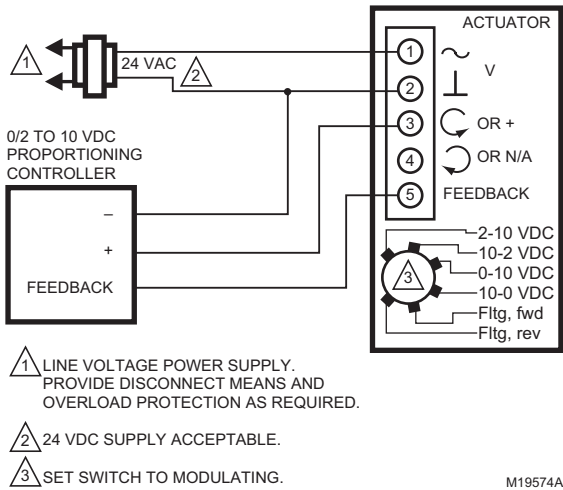

Fig. 18. Wiring for 0/2-10 Vdc proportioning controllers.

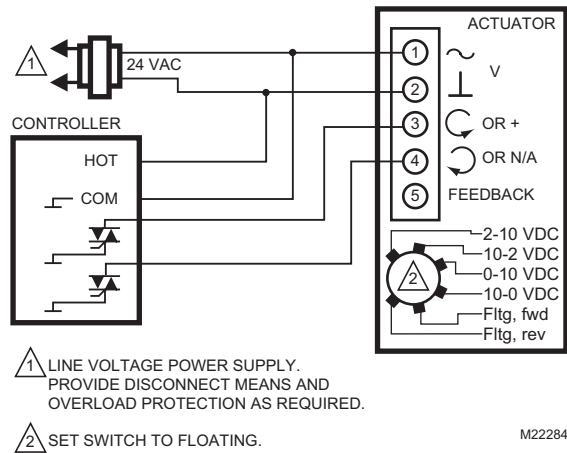

Fig. 21. Wiring for low side (triac sink) floating control.

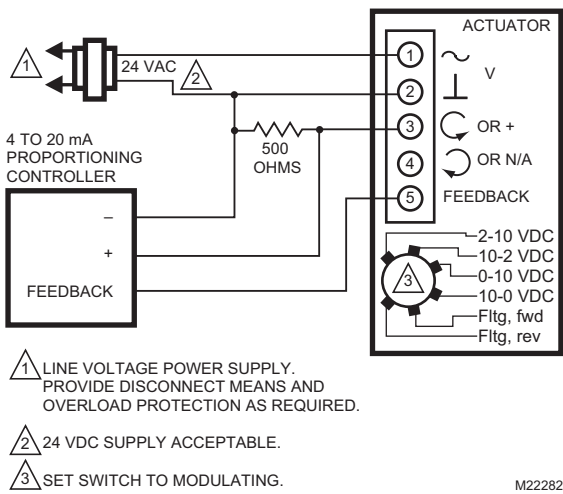

Fig. 19. Wiring for 4-20 mA proportioning controllers.

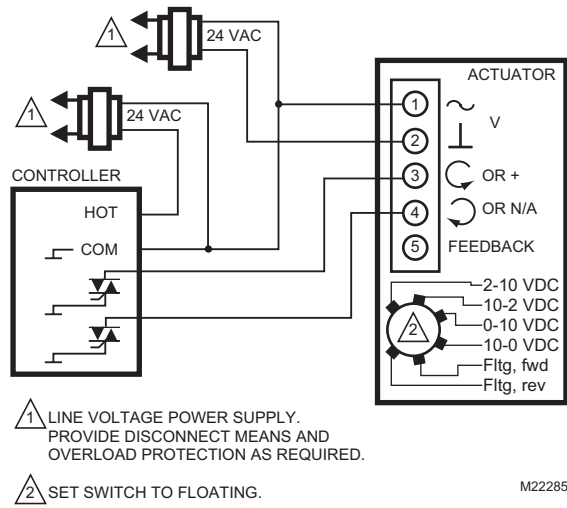

Fig. 22. Wiring for low side (triac sink) floating control using separate transformers.

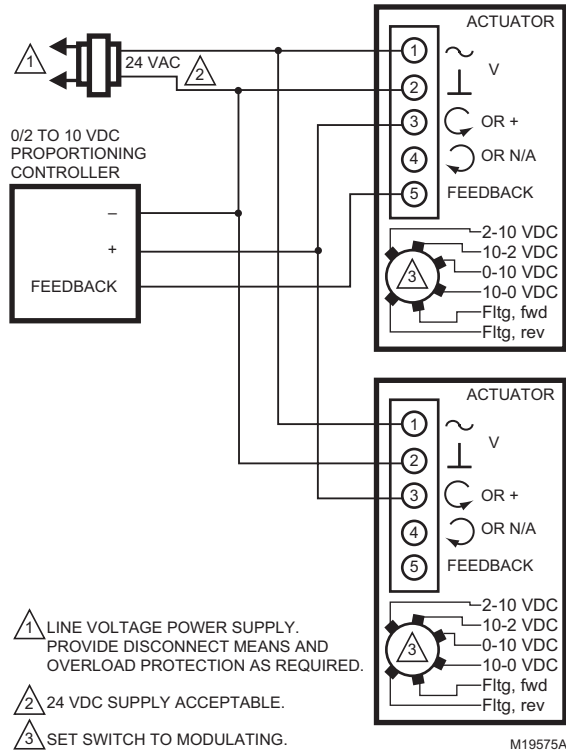

Fig. 23. Wiring for 0/2-10 Vdc proportioning controller operating multiple actuators.

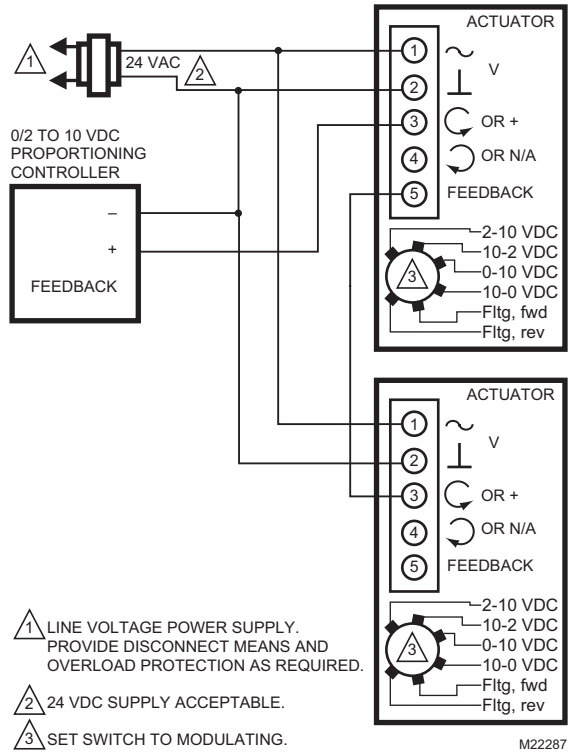

Fig. 25. Wiring for 0/2-10 Vdc proportioning controller operating multiple actuators as master/drone.

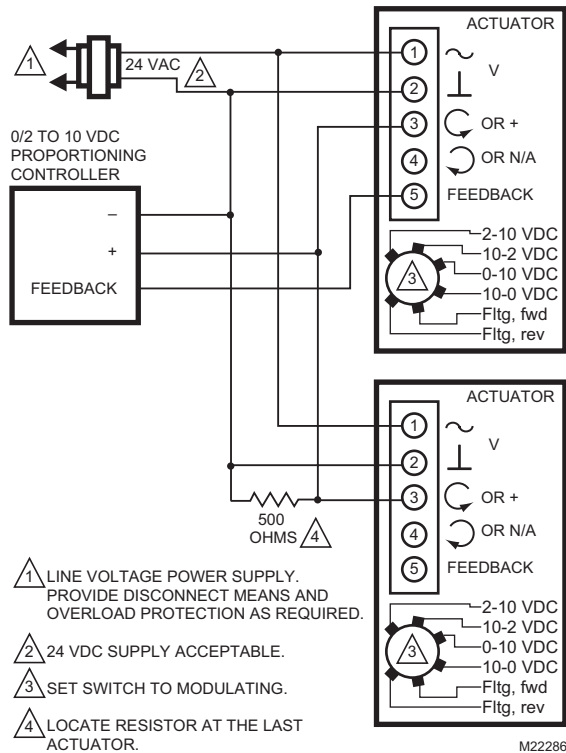

Fig. 24. Wiring for 4-20 mA proportioning controller operating multiple actuators.

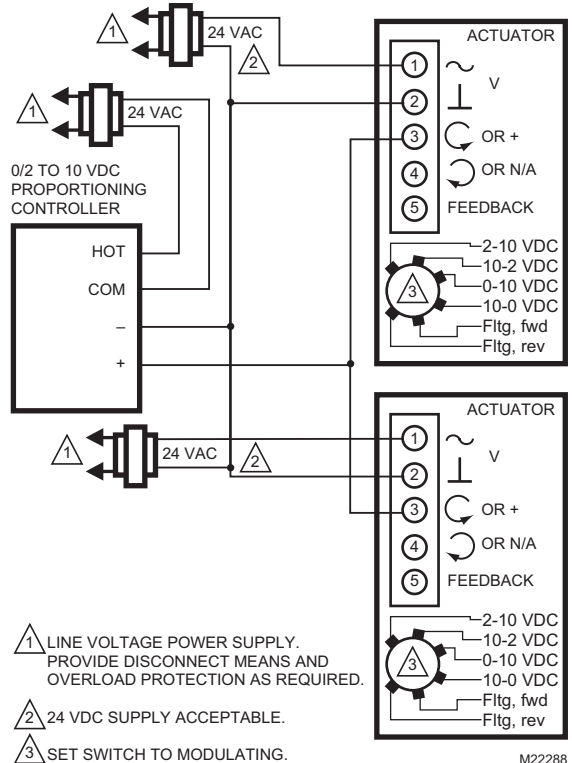

Fig. 26. Wiring for 0/2-10 Vdc proportioning controller operating multiple actuators with separate transformers.

OPERATION

The actuator is designed to be used in ventilating and air conditioning installations to operate valves, dampers, ventilation flaps and louvers requiring torque up to the rating. (For ratings, see the Specifications section.) If the power fails, the actuator will spring return to the start position.

The actuator is operated by a proportional controller. When using a proportional controller, the actuator drives toward its fully open position when the input signal increases; the actuator drives toward the fully closed position when the input signal decreases. The actuator stops when the input signal reaches the desired proportional control point.

IMPORTANT

The actuator is designed to respond to DDC Controller instantaneous contact closures. Take care not to short cycle the actuator. Unstable damper control can cause premature actuator failure.

Actuator Override

To override the control signal (for freeze protection or similar applications):

1. Override to full open:
 - a. Disconnect the input signal (from terminal 3).
 - b. Apply 24 Vac to terminal 3.
 - c. See Fig. 27.
2. Override to full closed:
 - a. Disconnect the input signal (from terminal 3).
 - b. See Fig. 28.

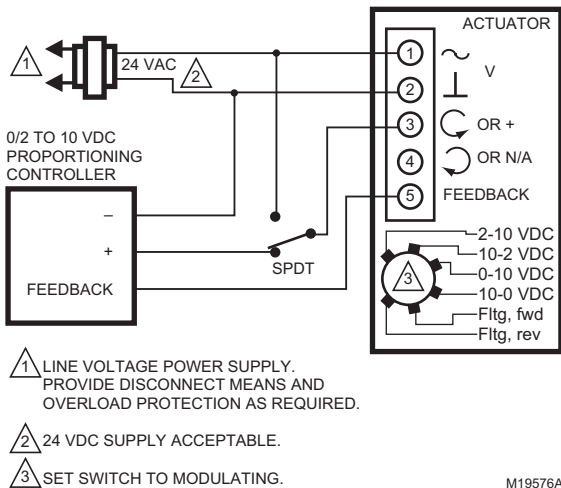

Fig. 27. Override to full open.

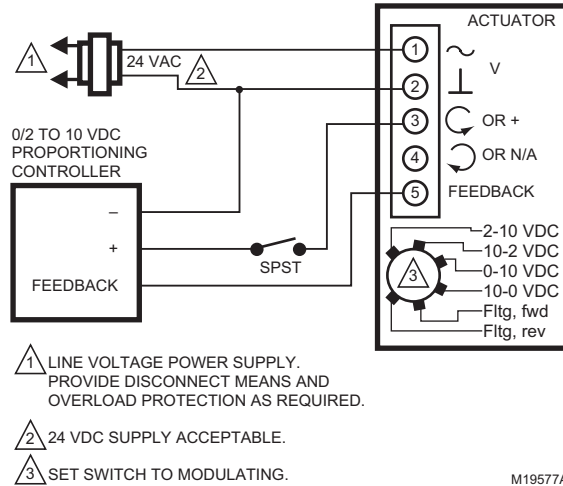

Fig. 28. Override to full close.

End Switches

Some models include end switches (see Table 2). For wiring details, see Fig. 11.

SPDT Switches (Fig. 29)

For SPDT end switch wiring, see Fig. 11.

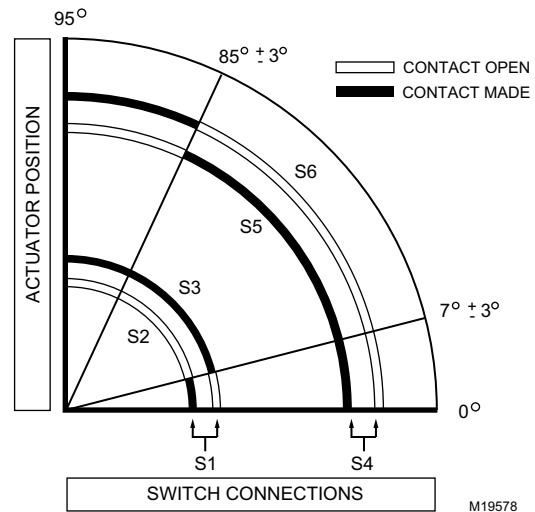





Fig. 29. SPDT End Switch Operation.

CHECKOUT

Modulating/Floating Operation

1. Mount actuator for required application (either clockwise  or counterclockwise  rotation to open the damper).
2. Connect power to terminals 1 and 2. (See Fig. 11 and Table 6.)
3. Set "Mode Select" dial to desired control signal. (See Fig. 4 and Table 5.)
4. Apply control signal for actuator 100% position. (See Fig. 11 and Table 6.)
 - a. (0)2-10 Vdc: apply 10 Vdc signal to terminal 3.
 - b. 10-(0)2 Vdc: apply (0)2 Vdc signal to terminal 3.
 - c. (0)4-20 mA: apply 20 mA signal to terminal 3.
 - d. 20-(0)4mA: apply (0)4 mA signal to terminal 3.
 - e. Floating: apply 24 Vac to appropriate CW (3) or CCW (4) terminal.
5. Actuator drives to 100% position.
6. Apply control signal for actuator 0% position. (See Fig. 11 and Table 6.)
 - a. (0)2-10 Vdc: apply (0)2 Vdc signal to terminal 3.
 - b. 10-(0)2 Vdc: apply 10 Vdc signal to terminal 3.
 - c. (0)4-20 mA: apply (0)4 mA signal to terminal 3.
 - d. 20-(0)4mA: apply 20 mA signal to terminal 3.
 - e. Floating: apply 24 Vac to appropriate CW (3) or CCW (4) terminal.
7. Actuator drives to 0% position.

Spring Return Operation

1. Mount actuator for required application (either clockwise  or counterclockwise  rotation to open the damper).
2. Connect power to terminals 1 and 2. (See Fig. 11 and Table 6.)





NOTE: For two-position models skip to step 5.
3. Set "Mode Select" dial to desired control signal. (See Fig. 4 and Table 5.)
4. Apply control signal for actuator 50% position. (See Fig. 11 and Table 6.)
 - a. Vdc Input Signal: apply 5-6 Vdc signal to terminal 3.
 - b. mA Input Signal: apply 10-12 mA signal to terminal 3.

- c. Floating: apply 24 Vac to appropriate CW (3) or CCW (4) terminal.
5. Allow the actuator to drive to 50% position.
6. Disconnect wire from terminal 1.
7. Actuator spring returns to 0% position.
8. Re-connect wire to terminal 1, actuator drives towards 100% position.



Feedback Operation

1. Connect a multi-meter, set for Vdc, to terminals 2 and 5.
2. Apply the same signal as in step 4 of Modulating Operation.
3. The multi-meter reading increases to match the input signal as actuator drives towards 100% position.
4. Apply the same signal as in step 6 of Modulating Operation.
5. The multi-meter reading decreases to match the input signal as actuator drives towards 0% position.

Direct Checkout

1. Mount actuator for required application (either clockwise  or counterclockwise  rotation to open the damper).
2. Check damper position and make sure that 24 Vac is present at the appropriate connections. (See Fig. 10.)
3. Apply control signal to the appropriate connections to move the damper to the opposite position. The actuator should drive the damper.
4. If actuator does not run, verify that the actuator is properly installed for either clockwise  or counterclockwise  rotation.
5. If actuator is correctly installed and still does not run, replace the actuator.

Two-Position Checkout

1. Mount actuator for required application (either clockwise  or counterclockwise  rotation to open the damper).
2. Check damper position and make sure that power is present at terminals 1 and 2.
3. Actuator drives to 100% position.
4. Disconnect power from terminals 1 and 2.
5. Actuator spring-returns to 0% position.
6. If actuator is correctly installed and does not run, replace the actuator.

Automation and Control Solutions

Honeywell International Inc.
1985 Douglas Drive North
Golden Valley, MN 55422
customer.honeywell.com

Honeywell Limited-Honeywell Limitée
35 Dynamic Drive
Toronto, Ontario M1V 4Z9

® U.S. Registered Trademark
© 2007 Honeywell International Inc.
63-2607—5 C.H. Rev. 02-07



Printed in U.S.A. on recycled
paper containing at least 10%
post-consumer paper fibers.

Honeywell