



## DSDF (DH-98) CONVENTIONAL DUCT DETECTOR



### STANDARD FEATURES

- Detects and limits the spread of smoke throughout building HVAC ducts
- Ability to interconnect (all relays operate with a single alarm) up to 30 units using the same independent power supply
- Compatible with building automation and fire alarm systems
- Installs quickly and easily
- Interchangeable "Plug-In" photoelectric or ionization heads
- No screens or filters to clean
- Cover provides magnet window and placement guide for operational testing without disassembly
- Rugged gray steel back box with clear cover
- Accessories - Remote power, remote alarm indication capability and remote, horn/piezo capability
- Meets UL268A Requirements

### PRODUCT LISTINGS

Underwriters Laboratories 81383  
CSFM # 3240-0410:155  
FM # 3005751

### SPECIFICATIONS

#### OPERATING VOLTAGE

115V AC, 24V AC/DC

#### DETECTOR HEAD MODEL

SLJ-24DH

#### DETECTOR HEAD TYPE

Conventional Photoelectric

#### POWER REQUIREMENTS STANDBY

115V VAC – 14mA

24 VAC – 20mA

24 VDC – 13mA

#### POWER REQUIREMENTS ALARM

115V VAC – 28mA

24 VAC – 95mA

24 VDC – 60mA

#### ALARM CONTACTS

1 form "C" and 1 form "A" rated at 10 amps @ 115 V.A.C.

#### DETECTION LOOP

1 Form A (1A)

#### TROUBLE CONTACTS

1 Form "C"

#### SENSITIVITY TEST METHOD

Self Diagnostic Test

#### REMOTE INDICATION CAPABILITY

(Refer to DH-98 Accessories Data Sheet for Specification)  
Power, Alarm, Horn/Piezo, Test

#### AIR VELOCITY

300 to 4000 ft./min.

#### AMBIENT TEMPERATURE

32°F to 120°F (0°C TO 49°C)

#### HUMIDITY

10% to 85% Relative Humidity (non-condensing)

#### HOUSING MATERIAL

18 G.A. steel backbox, clear plastic cover

#### FINISH

Grey Paint

#### DIMENSIONS

9 1/8" l x 7 1/4" w x 2 1/4" h

#### MAXIMUM NET WEIGHT

3 lbs.

#### SAMPLING TUBES

2.5 FT., 5 ft. OR 10 ft.

## DESCRIPTION

The HOCHIKI AMERICA DH-98 (DSDF) Duct Smoke Detector provides early detection of smoke and products of combustion present in air moving through HVAC ducts in Commercial, Industrial and Residential applications. The DH-98 is designed to prevent the recirculation of smoke in areas by the air handling systems, fans and blowers. Complete systems may be shut down in the event of smoke detection. The HOCHIKI AMERICA DH-98-1 and the DH-98-P operate on 115 VAC, 24 VAC and 24 VDC and the DH-98-HVI and the DH-98-HVP operate on 230 VAC, 24 VAC and 24 VDC.

The DH-98 is designed and built to meet all local requirements, as well as the NFPA regulations regarding duct smoke detectors. Output terminals are provided for remote accessories such as a horn, strobe, remote status indicators and reset key switches or push buttons.

Air sampling is accomplished by two tubes which protrude into the duct. An exhaust tube of one standard length (7.5") is supplied in the installation kit with the smoke duct unit. Once the duct width has been determined the air intake sampling tubes must be ordered. Sampling tubes are supplied in three standard lengths 2.5 ft., 5 ft. and 10 ft. and cut to size to fit the duct. Mounting the duct smoke unit is accomplished by the use of a template and 4 sheet metal screws, which are provided. Mounting can be achieved without the removal of the clear cover which is secured by 4 capture screws.

The compact DH-98 contains 3 sets of alarm contacts, 1 set of form "C" contacts rated at 10 amps, 1 set of form "A" contacts rated at 10 amps, 1 set of form "A" contacts rated at 1 amp. There is also 1 set of form "C" 10 amp trouble contacts for monitoring detector head removal, and the failure of the input supply voltage.

The pilot and alarm visual indicators provided on the front of the DH-98 duct unit, signal the operating status of the device. A manual test/reset switch is located along side the visual indicators. This switch can be defeated by cutting a jumper on the PCB.

## ENGINEERING SPECIFICATIONS

Air duct smoke detectors shall be HOCHIKI AMERICA DH-98 Series. The detectors shall be listed by Underwriters Laboratories per UL 268A. The detectors shall operate at air velocities from 300 feet per minute to 4000 feet per minute. The detectors shall have the ability to interconnect up to 30 units using the same independent power supply.

The duct detector housings shall be of metal construction and complete mechanical installation may be performed without removal of detector cover. Visual indication of alarm and power must be provided on detector front. A manual reset switch shall be located on front of the device. Detector heads shall not require additional filters or screens which must be maintained. The housing shall contain a detector base which will accept photoelectric or ionization detector heads. Terminal connections shall be of the screw type and be a minimum of #6 screw. Terminals shall be provided for remote pilot, remote alarm indication, strobe/horn and remote key switch. All wiring must comply with local codes and regulations.

## WIRING DIAGRAMS

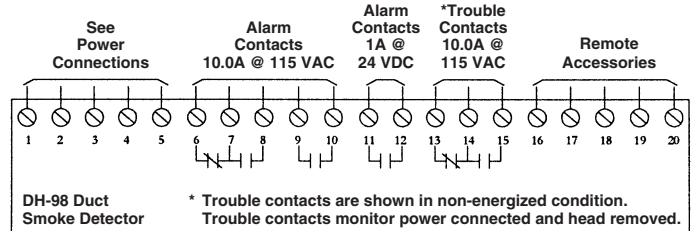

20 VAC 60 Hz Input @ 0.1 AMP Max.  
(Detector only) up to 1.9 AMPS for  
auxiliary outputs (horns/strobes)

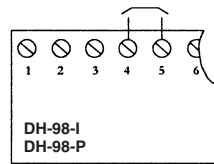

24 VAC 60 Hz Input @ 0.1 AMP Max.  
(Detector only) up to 1.9 AMPS for  
auxiliary outputs (horns/strobes)

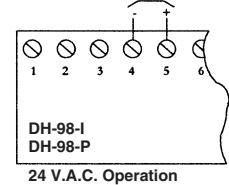

115 VAC 60 Hz Input  
@ 0.1 AMP Max.

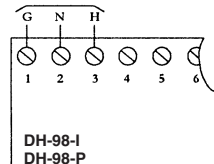

230 VAC 60 Hz Input  
@ 0.1 AMP Max.

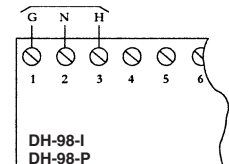

## INTERCONNECT WIRING DIAGRAMS

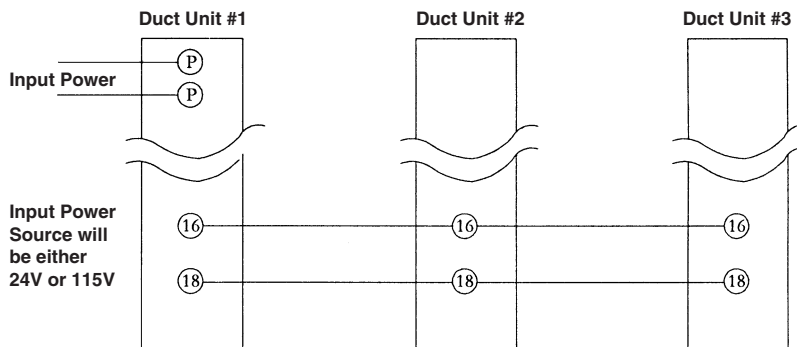

# RUSKIN®

3900 Dr. Greaves Rd.  
Kansas City, MO 64030  
(816) 761-7476  
FAX (816) 765-8955  
www.ruskin.com