

## EAMP ELECTRONIC AIR & TEMPERATURE MONITORING PROBE

### APPLICATION

The EAMP is a highly accurate electronic thermal dispersion type air measuring device that averages multiple velocity and temperature points in the duct or plenum in which it is installed. The airfoil shaped probe ensures the lowest pressure drop and least noise. The transmitter comes standard with an LCD display to indicate the airflow and temperature. Each sensor circuit is equipped with velocity and temperature thermistors that are individually tested to NIST traceable standards. At each sensing point, a microprocessor calculates flow and temperature, sending this information to an integral multiplexing unit. The microprocessor based multiplexing unit collects data from each sensor circuit and sends a digital output to the transmitter. Each measuring point on every probe is factory tested and calibrated to ensure the highest accuracy. Since the calibration data is stored within each probe, it is not necessary to match the probe to a specific transmitter. Each transmitter is capable of averaging up to four probes and sixteen sensing points. The transmitter communicates temperature and velocity with any building automation system through analog outputs.

### STANDARD CONSTRUCTION

#### PROBE

Airfoil shaped 2" x 3/4" (51mm x 19mm) 6063T6 high yield extruded aluminum (mill finish)

#### MOUNTING BRACKETS

.080 (2mm) aluminum (mill finish)

#### SENSOR ACCURACY

Airflow:  $\pm 2\%$  of reading and  $\pm 0.25\%$  repeatability  
Temperature:  $\pm 0.10^\circ\text{F}$

#### PROBE RANGES

Airflow Rate: 0-4000 FPM (0-20 m/s)  
Temperature:  $-25^\circ\text{F}$  to  $140^\circ\text{F}$  ( $-32^\circ\text{C}$  to  $60^\circ\text{C}$ )  
Humidity: 0-99% RH, non-condensing

#### POWER REQUIREMENT

24 VAC transformer

#### SENSOR DISTRIBUTION

Equal area

#### CALIBRATED METERED ORIFICE

U.L. 94 flame rated, high Impact ABS

#### SENSOR CIRCUIT (up to four per probe assembly)

One glass encapsulated, hermetically sealed, heated thermistor  
One glass encapsulated, hermetically sealed, ambient thermistor  
One microprocessor based multiplexer circuit

#### CONTROL TRANSMITTER

##### EAMP020 Digital Controller (reference catalog sheet)

16x2 character alphanumeric LCD display (airflow, temperature & diagnostics)

Velocity Output: 4-20mA or 2-10 VDC using 500 ohm resistor

Temperature Output: 4-20mA or 2-10 VDC using 500 ohm resistor.

##### OPERATING RANGE:

Temperature:  $-20^\circ\text{F}$  to  $120^\circ\text{F}$  ( $-29^\circ\text{C}$  to  $49^\circ\text{C}$ )

Humidity: 0-99% RH, non-condensing

#### AGENCY LISTINGS

All components are U.L. Listed and compliant with Part 15 of the FCC rules and RoHS directive 2002/95/EC

UL 444 plenum rated shielded CAT5e communication cable (10' [3.05m] standard) NEC/CEC Type CMP (NFPA 262) Internal Probe Wiring VW-1 UL 1581 PVC coated copper

#### DUCT/PLENUM SIZE

Width: 12" to 120" (305mm to 3050mm)

Height: 12" to 120" (305mm to 3050mm)

**Note:** Values shown in ( ) indicate metric units.

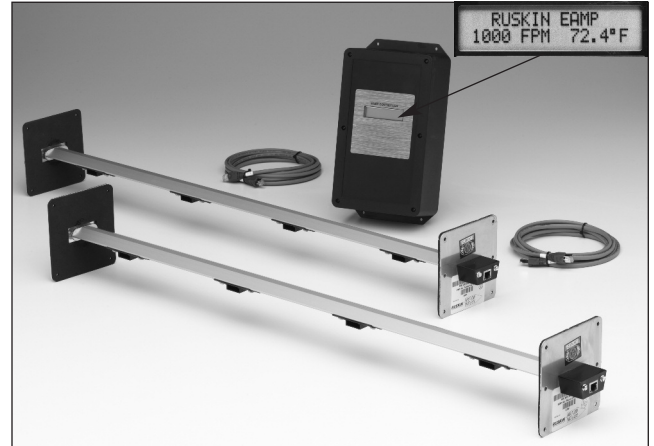

EAMP with standard EAMP020 Transmitter  
Displays Velocity or CFM (m<sup>3</sup>/s) and Temperature

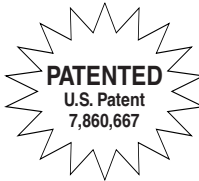

### FEATURES

- Ruskin thermal dispersion measurement technology provides accurate, repeatable measurement from zero to maximum airflow utilizing NIST traceable calibration standards.
- Airfoil shaped probe to reduce noise and pressure drop
- Repeatable and accurate measurement from 0 to 4000 FPM (0-20 m/s)
- Transmitter is interchangeable with any Ruskin probe
- Standard LCD display shows Velocity or Flow & Temperature
- Communicates with any building automation system (BAS) through analog outputs (4-20mA or 2-10 VDC)
- Digital wind filter
- Digital output filter

Ruskin EAMP helps satisfy the requirements for minimum outside air as required by the following.

- LEED (USGBC)
- ASHRAE 62.1, ASHRAE 90.1 and ASHRAE 189.1.
- California Title 24
- International Mechanical Code (IMC)
- International Energy Conservation Code (IECC)

### VARIATIONS

Ruskin model EAMP is available with the following variations at additional cost.

- Clear anodized finish
- Stainless mounting hardware
- Standoff mounting hardware
- Internal mounting hardware
- Longer communication cable(s)
- Lower Sensor Density

### WARRANTY

36 months from shipping date (parts only).

Refer to Ruskin Standard Terms & Conditions for additional information.

# ORDER & INSTALLATION DETAILS

Probe kit comes with standard (#1) transmitter and utilizes thermal dispersion technology to calculate the airflow and average the temperature. Two thermistors at multiple sensing points (#5) measure ambient temperature and velocity. One or more sensing points are housed in a high impact, ABS plastic, calibrated metered orifice that is mechanically fastened to the airfoil probe (#4). The probe and sensor circuit density are based on the duct or plenum size (DETAIL A) and corresponding density chart. Orders are based on the inside dimensions where "A" is the duct or plenum width and "B" is the duct or plenum height. The sensor readings are multiplexed with a micro-processor and digitally communicated to the control transmitter motherboard through plenum rated shielded CAT5e cable (#2). The calibration data for each probe is stored inside the multiplexer (#3), making any probe interchangeable with any control transmitter.

- 1. Transmitter
- 2. Shielded CAT5e Communication/Power Cable
- 3. Multiplexer
- 4. Probe\*
- 5. Sensing Point

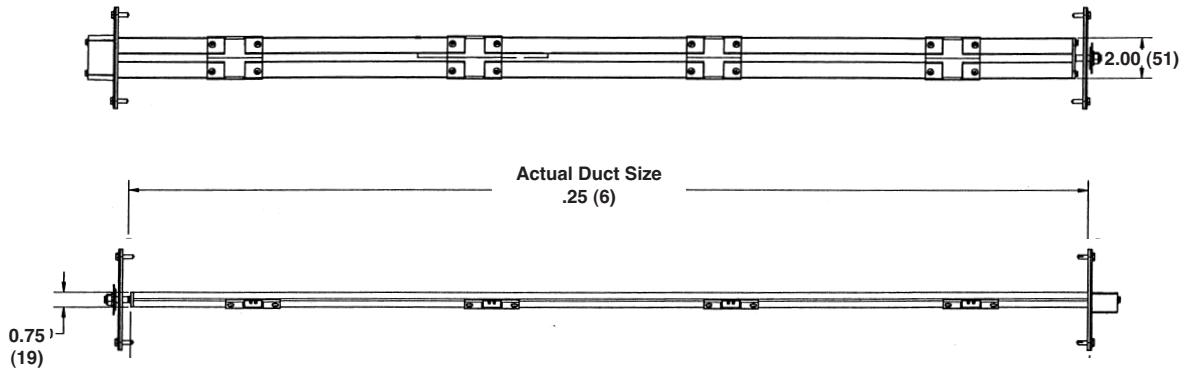
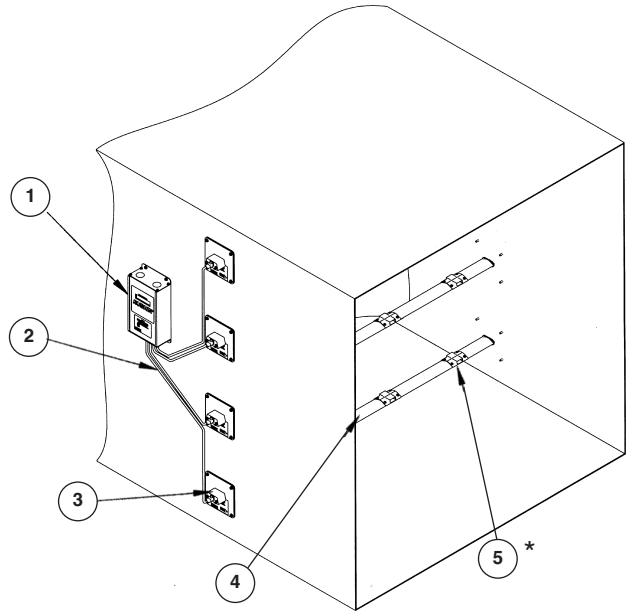

**PROBE DETAIL**

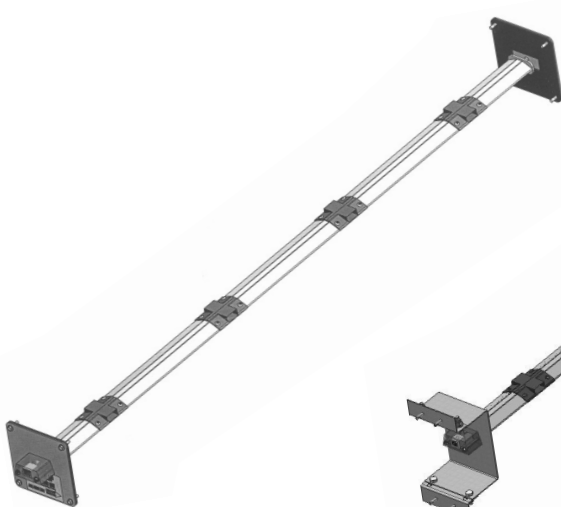

**INSERTION MOUNTING\***  
(Duct & Plenum Applications)



**INTERNAL MOUNTING\***  
(Plenum Applications)

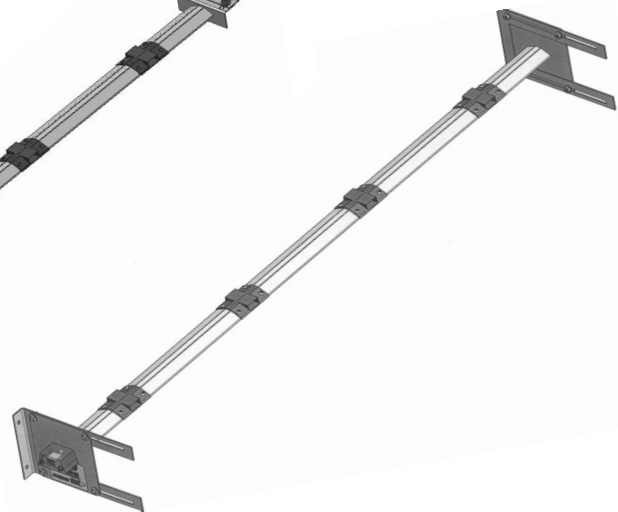

**STAND-OFF MOUNTING\***  
(Damper Face Applications)

Probe may be installed in square, round or oval ducts and plenums. The insertion style mounting bracket is standard but the probe also comes with a stand-off mounting option for applications that require probes mounted inside of a plenum, or on the air entering face of a

Ruskin model CD50 or CD60 damper (damper sold separately). The information on this catalog sheet is for general reference. For specific installation and operation details see the Installation and Maintenance Instructions.

*\*Sensors shown on top of probe for illustration only. Install with sensors on bottom of probe when installed horizontally.*

## SENSOR DENSITY DETAILS (SQUARE)

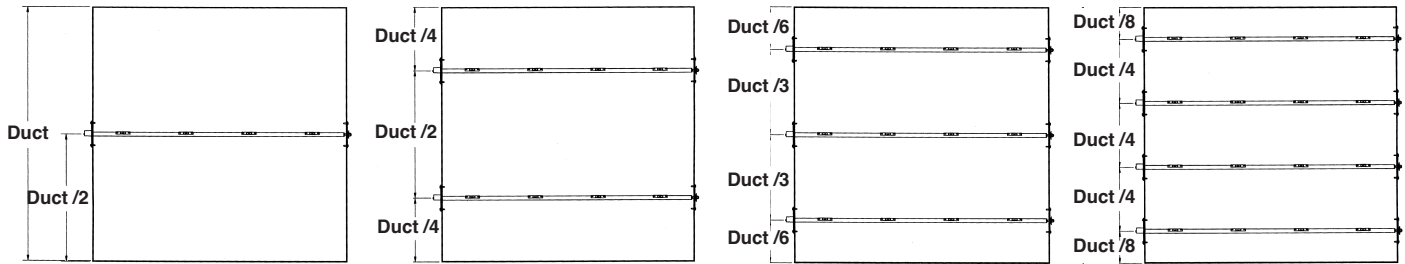

| DUCT HEIGHT "B" | DUCT WIDTH "A" |           |           |           |           |            |            |            |            |            |            |            |            |             |             |
|-----------------|----------------|-----------|-----------|-----------|-----------|------------|------------|------------|------------|------------|------------|------------|------------|-------------|-------------|
|                 | 12" (305)      | 18" (457) | 24" (610) | 30" (762) | 36" (914) | 42" (1067) | 48" (1219) | 54" (1372) | 60" (1524) | 66" (1676) | 72" (1829) | 84" (2134) | 96" (2438) | 108" (2743) | 120" (3048) |
| 12" (305)       | 2/2            | 2/2       | 1/4       | 1/4       | 1/4       | 1/4        | 1/4        | 1/4        | 1/4        | 1/4        | 1/4        | 1/4        | 1/4        | 1/4         | 1/4         |
| 18" (457)       | 2/2            | 2/2       | 2/2       | 2/2       | 2/3       | 2/3        | 2/3        | 2/3        | 2/3        | 2/4        | 2/4        | 2/4        | 2/4        | 2/4         | 2/4         |
| 24" (610)       | 2/2            | 2/2       | 2/3       | 2/3       | 2/3       | 2/3        | 2/4        | 2/4        | 2/4        | 2/4        | 2/4        | 2/4        | 2/4        | 2/4         | 2/4         |
| 30" (762)       | 2/2            | 3/1       | 3/2       | 2/3       | 2/3       | 2/4        | 2/4        | 2/4        | 2/4        | 2/4        | 2/4        | 2/4        | 2/4        | 2/4         | 2/4         |
| 36" (914)       | 2/2            | 3/2       | 3/2       | 3/2       | 2/4       | 2/4        | 2/4        | 2/4        | 2/4        | 2/4        | 2/4        | 2/4        | 2/4        | 2/4         | 2/4         |
| 42" (1067)      | 3/2            | 3/2       | 3/2       | 3/3       | 4/2       | 3/4        | 3/4        | 3/4        | 4/4        | 4/4        | 4/4        | 4/4        | 4/4        | 4/4         | 4/4         |
| 48" (1219)      | 3/2            | 3/2       | 4/2       | 4/2       | 4/3       | 4/3        | 4/4        | 4/4        | 4/4        | 4/4        | 4/4        | 4/4        | 4/4        | 4/4         | 4/4         |
| 54" (1372)      | 3/2            | 3/2       | 4/2       | 4/2       | 4/3       | 4/3        | 4/4        | 4/4        | 4/4        | 4/4        | 4/4        | 4/4        | 4/4        | 4/4         | 4/4         |
| 60" (1524)      | 3/2            | 3/2       | 4/3       | 4/3       | 4/3       | 4/4        | 4/4        | 4/4        | 4/4        | 4/4        | 4/4        | 4/4        | 4/4        | 4/4         | 4/4         |
| 66" (1676)      | 3/2            | 4/2       | 4/3       | 4/3       | 4/4       | 4/4        | 4/4        | 4/4        | 4/4        | 4/4        | 4/4        | 4/4        | 4/4        | 4/4         | 4/4         |
| 72" (1829)      | 3/2            | 4/2       | 4/4       | 4/4       | 4/4       | 4/4        | 4/4        | 4/4        | 4/4        | 4/4        | 4/4        | 4/4        | 4/4        | 4/4         | 4/4         |
| 84" (2134)      | 4/2            | 4/2       | 4/4       | 4/4       | 4/4       | 4/4        | 4/4        | 4/4        | 4/4        | 4/4        | 4/4        | 4/4        | 4/4        | 4/4         | 4/4         |
| 96" (2438)      | 4/2            | 4/3       | 4/4       | 4/4       | 4/4       | 4/4        | 4/4        | 4/4        | 4/4        | 4/4        | 4/4        | 4/4        | 4/4        | 4/4         | 4/4         |
| 108" (2743)     | 4/2            | 4/3       | 4/4       | 4/4       | 4/4       | 4/4        | 4/4        | 4/4        | 4/4        | 4/4        | 4/4        | 4/4        | 4/4        | 4/4         | 4/4         |
| 120" (3048)     | 4/2            | 4/3       | 4/4       | 4/4       | 4/4       | 4/4        | 4/4        | 4/4        | 4/4        | 4/4        | 4/4        | 4/4        | 4/4        | 4/4         | 4/4         |

### DETAIL A

Probe/sensor placement for rectangular applications

## SENSOR DENSITY DETAILS (ROUND)

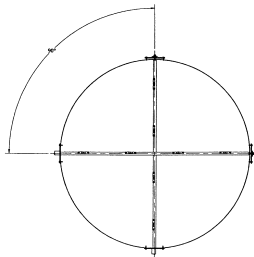

DETAIL 1

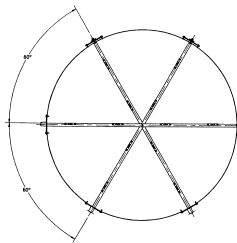

DETAIL 2

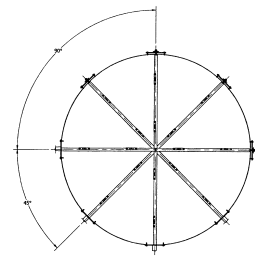

DETAIL 3

| DUCT DIAMETER | # OF PROBES | # OF SENSORS PER PROBE | DETAIL # |
|---------------|-------------|------------------------|----------|
| 12" (305)     | 2           | 2                      | 1        |
| 18" (457)     | 2           | 2                      | 1        |
| 24" (610)     | 2           | 2                      | 1        |
| 36" (914)     | 2           | 4                      | 1        |
| 42" (1067)    | 2           | 4                      | 1        |
| 48" (1219)    | 3           | 4                      | 2        |
| 60" (1524)    | 4           | 4                      | 3        |
| 72" (1829)    | 4           | 4                      | 3        |
| 96" (2438)    | 4           | 4                      | 2        |
| 120" (3048)   | 4           | 4                      | 3        |

### DETAIL B

Probe/sensor placement for round applications

## SENSOR DENSITY DETAILS (OVAL)

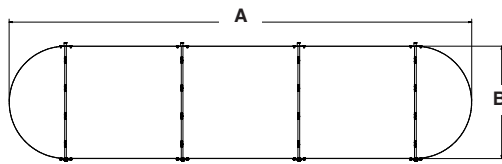
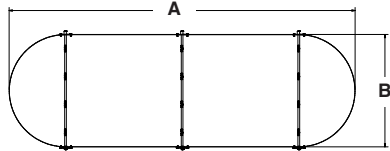
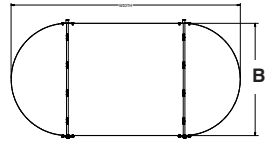
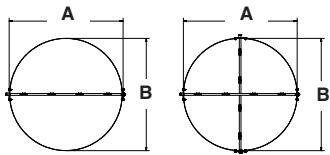

| PROBE LENGTH<br>DUCT HEIGHT "B" | DUCT WIDTH "A" |              |              |              |               |               |               |               |               |                |
|---------------------------------|----------------|--------------|--------------|--------------|---------------|---------------|---------------|---------------|---------------|----------------|
|                                 | 12"<br>(305)   | 18"<br>(457) | 24"<br>(610) | 36"<br>(914) | 42"<br>(1067) | 48"<br>(1219) | 60"<br>(1524) | 72"<br>(1829) | 96"<br>(2438) | 120"<br>(3048) |
| 12" (305)                       | 2/2            | 2/2          | 1/3          | 1/3          | 3/2           | 3/2           | 4/2           | 4/2           | 4/2           | 4/2            |
| 18" (457)                       |                | 2/2          | 1/3          | 1/3          | 3/2           | 3/2           | 4/2           | 4/2           | 4/2           | 4/2            |
| 24" (610)                       |                |              | 2/2          | 2/3          | 3/2           | 3/2           | 4/2           | 4/2           | 4/2           | 4/2            |
| 36" (914)                       |                |              |              | 2/4          | 3/3           | 3/3           | 4/3           | 4/3           | 4/3           | 4/3            |
| 42" (1067)                      |                |              |              |              | 2/4           | 3/3           | 4/3           | 4/3           | 4/3           | 4/3            |
| 48" (1219)                      |                |              |              |              |               | 3/4           | 4/4           | 4/4           | 4/4           | 4/4            |
| 60" (1524)                      |                |              |              |              |               |               | 4/4           | 4/4           | 4/4           | 4/4            |
| 72" (1829)                      |                |              |              |              |               |               |               | 4/4           | 4/4           | 4/4            |
| 96" (2438)                      |                |              |              |              |               |               |               |               | 4/4           | 4/4            |
| 120" (3048)                     |                |              |              |              |               |               |               |               |               | 4/4            |

\*Probes run vertically in "B" dimension (height of opening).

### DETAIL C

Probe/sensor placement for oval applications

## TECHNOLOGY

Ruskin EAMP series probes utilize thermal dispersion technology to measure the airflow in the most demanding applications.

The mathematically defined relationship between heat transfer rate and airflow velocity make it possible to accurately measure flow by elevating a thermal temperature sensor and placing it in the airstream with an ambient air temperature sensor as a reference. The heated sensor is elevated to a stipulated temperature differential above the reference point. The velocity is calculated using the reference point (ambient), the known heat transfer characteristics of the heated sensor, and the power expenditure necessary to maintain the delta between the heated sensor and the ambient reference sensor (ref. Detail 1) right.

The airfoil shape of the probe, calibrated metered orifice and placement of the sensors are all based on results from computational

fluid dynamics and extensive lab testing. Ruskin's unique design provides lower pressure drop, when compared to round probe designs, and accurate measurement of flow and temperature.

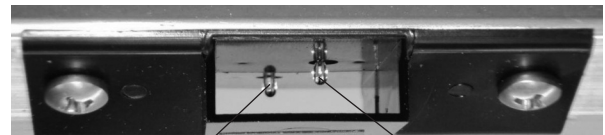

Heated Sensor

Ambient Sensor

### DETAIL 1

TYPICAL SENSING POINT

## SUGGESTED SPECIFICATION

Furnish and install, at locations shown on plans or as in accordance with schedules, an electronic thermal dispersion type airflow temperature measuring station (AFTMS). AFTMS shall be capable of monitoring and reporting the airflow and temperature at each measuring location through one or more measuring probes containing multiple sensor points and a transmitter that communicates with the building automation system (BAS). Probe(s) shall be constructed of an airfoil shaped 6063T6 aluminum extrusion containing the sensor circuit(s). Each sensor circuit shall consist of thermistors, for velocity and temperature, mounted to a printed circuit board (PCB). Factory calibration of thermal dispersion sensors shall be at sixteen airflow rates between 0 and 5,000 FPM using NIST traceable calibration standards. Probe multiplexer circuit(s) shall include a microprocessor that collects data from each PCB and digitally communicates the average airflow and temperature of each probe to the microprocessor-based control transmitter. Multiplexer board shall be completely encased in electrical potting material to prevent moisture damage. Readily available UL Plenum

rated shielded CAT5e communications cable with RJ45 terminal connectors, dust boot covers and gold plated contacts shall link probe(s) to control transmitter. Proprietary cables are not acceptable. Complete assembly shall be constructed and calibrated in an ISO 9001 certified facility following strict ISO calibration test procedures. Shielded communications cable shall be a minimum of 10' (3.05m) in length. Transmitter shall be capable of processing up to 16 independent sensing points per airflow measuring location and shall operate on a fused 24 VAC supply. Transmitter shall feature a 16x2 character alphanumeric LCD display, digital offset/gain adjustment, continuous performing sensor/transmitter diagnostics and a visual alarm to detect malfunctions. LCD shall be field adjustable to display either I.P. or S.I. units. Transmitter output shall be field adjustable 4-20 mA or 2-10 VDC. All electronic components of the assembly shall be lead-free RoHS compliant. Accuracy shall be based on tests and procedures performed in accordance with AMCA publication 611. AFTMS shall be in all respects equivalent to Ruskin model EAMP.

# RUSKIN®

3900 Dr. Greaves Rd.  
Kansas City, MO 64030  
(816) 761-7476  
FAX (816) 765-8955  
www.ruskin.com